



HAYWARD®

S.Line Pro Fi

POMPE A CHALEUR POUR PISCINE
SWIMMING POOL HEAT PUMP UNIT
UNIDAD DE BOMBA DE CALOR PARA PISCINAS
BOMBA DE AQUECIMENTO PARA PISCINAS
HEIZPUMPENANLAGE FÜR EIN SCHWIMMBECKEN
ZWEMBAD WARMTEPOMP
UNITÀ DI RISCALDAMENTO A POMPA DI CALORE PER PISCINE
VARMEPUMPE TIL SVØMMEBASSENG
VÄRMEPUMP FÖR BASSÄNG
ТЕПЛОВОЙ НАСОС ДЛЯ ПЛАВАТЕЛЬНОГО БАСЕЙНА



Manuel d'instructions et d'installation
Installation & Instruction Manual
Manual de Instalación e Instrucciones
Manual de instalação e de instruções
Einbau- & Anleitungshandbuch
Installatie- en bedieningshandleiding
Manuale d'Uso e di Installazione
Installerings- og brukerveiledning
Bruksanvisning och installationsmanual
Руководство по монтажу и эксплуатации



HAYWARD[®]

S.Line Pro *Fi*

POMPE A CHALEUR POUR PISCINE



Manuel d'instructions et d'installation

SOMMAIRE

1. PRÉFACE	1
<hr/>	
2. CARACTÉRISTIQUES TECHNIQUES	4
2.1 Données techniques de la pompe à chaleur	4
2.2 Plage de fonctionnement	5
2.3 Dimensions	6
<hr/>	
3. INSTALLATION ET RACCORDEMENT	7
3.1 Schéma de principe	7
3.2 Pompe à chaleur	7
3.3 Raccordement hydraulique	8
3.4 Raccordement électrique	9
3.5 Premier démarrage	10
<hr/>	
4. INTERFACE UTILISATEUR	12
4.1 Présentation générale	12
4.2 Réglage du débit d'eau	14
4.3 Réglage l'horloge	15
4.4 Réglage des Timers Marche/Arrêt	15
4.5 Réglage de la fonction Timer en mode SILENCE	17
4.6 Appairage Bluetooth - Commande à distance	18
4.7 Choix du mode de fonctionnement	19
4.8 Réglage et visualisation du point de consigne	20
4.9 Verrouillage et déverrouillage de l'écran tactile	21
<hr/>	
5. ENTRETIEN ET HIVERNAGE	22
5.1 Entretien	22
5.2 Hivernage	22
<hr/>	
6. ANNEXES	23
6.1 Schémas électriques	23
6.2 Raccordements priorité chauffage Pompe Monophasé	25
6.3 Vues éclatées et pièces détachées	26
6.4 Guide de dépannage	30
6.5 Garantie	33

À lire attentivement et à conserver pour une consultation ultérieure.

Ce document doit être remis au propriétaire de la piscine et doit être conservé par celui-ci en lieu sûr.

1. PRÉFACE

Nous vous remercions d'avoir acheté cette pompe à chaleur de piscine Hayward. La pompe à chaleur S.LINE PRO a été conçue selon des normes strictes de fabrication pour satisfaire les plus hauts niveaux de qualité requis.

Les pompes à chaleur S.LINE PRO vont vous offrir d'exceptionnelles performances tout au long de votre saison de baignade en adaptant la puissance, la consommation électrique et le niveau sonore au besoin de chauffage de votre piscine grâce à la logique de contrôle FULL INVERTER.



Lisez attentivement les consignes de ce manuel avant d'utiliser l'appareil.

Les pompes à chaleur S.LINE PRO sont exclusivement destinées à chauffer l'eau de piscine, ne pas utiliser ce matériel à d'autres fins.

Le présent manuel inclut toutes les informations nécessaires concernant l'installation, l'élimination des dysfonctionnements et l'entretien.

Lisez attentivement ce manuel avant d'ouvrir l'unité, ou de réaliser des opérations d'entretien sur celle-ci. Le fabricant de ce produit ne sera en aucun cas tenu responsable en cas de blessure d'un utilisateur ou d'un endommagement de l'unité suite à d'éventuelles erreurs lors de l'installation, de l'élimination des dysfonctionnements, ou d'un entretien inutile. Il est primordial de suivre à tout moment les instructions spécifiées dans ce manuel.

Toute recommandation non suivie annule la garantie.

1. PRÉFACE (suite)



Consignes de sécurité



Cet appareil contient du R32.

Ne jamais utiliser un réfrigérant autre que du R32. Tout autre corps gazeux mélangé avec le R32 risque de provoquer des pressions anormalement élevées pouvant conduire à une panne ou à une rupture de tuyaux et blesser des personnes.

Lors de réparations ou d'opérations de maintenance utiliser des tubes de cuivre conformes à la Norme EN 12375-1 (Mai 2020) et à la Directive Européenne des équipements sous pression 97/23/CE.

La pompe à chaleur étant sous pression ne jamais percer les tuyaux ni tenter de faire une brasure. Il y a risque d'explosion.

Ne jamais exposer l'appareil à des flammes, des étincelles ou autre sources d'allumage. Il pourrait exploser et entraîner des blessures graves voire mortelles.



La pompe à chaleur est exclusivement prévue pour une installation à l'extérieur des bâtiments.

- En cas de stockage la pompe à chaleur doit être stockée dans une pièce bien ventilée et d'une surface au sol de plus de A_{\min} (m²) donnée par la formule suivante : $A_{\min} = (M / (2.5 \times 0.22759 \times h_0))^2$
M est la charge de réfrigérant dans l'appareil en kg et h₀ est la hauteur de stockage. Pour un stockage au sol h₀ = 0,6 m.
- L'unité doit être installée par un personnel qualifié.
- Ne pas installer la pompe à chaleur sur un support risquant d'amplifier les vibrations de l'unité.
- Vérifier que le support prévu pour l'unité est convenablement dimensionné pour le poids de l'appareil.
- Ne pas installer la pompe à chaleur dans un endroit susceptible d'amplifier son niveau sonore ou dans un endroit où le bruit de l'unité risquerait de gêner le voisinage.
- Tous les raccordements électriques doivent être effectués par un électricien professionnel qualifié et selon les normes en vigueur dans le pays d'installation cf § 3.4.

1. PRÉFACE (suite)

- Couper l'alimentation principale et le sectionneur avant tous travaux électriques. Tout oubli peut être cause d'électrocution.
- Avant l'installation vérifier que le câble de terre n'est pas coupé ou déconnecté. Raccorder et serrer convenablement le câble d'alimentation électrique. Si la connexion est mauvaise, des parties électriques peuvent être endommagées.
- L'exposition de la pompe à chaleur à l'eau ou à un milieu humide risque de provoquer une électrocution. Soyez très vigilant.
- Si vous détectez tout défaut ou situation anormale, n'installez pas la pompe à chaleur et contactez immédiatement votre revendeur.
- L'entretien et les différentes opérations doivent être réalisés à la fréquence et aux moments recommandés, tel que spécifié dans le présent manuel.
- Les réparations doivent être effectuées par un personnel qualifié.
- N'utilisez que des pièces détachées d'origine.
- Ne jamais utiliser un autre procédé de nettoyage que celui préconisé dans ce manuel.

Informations importantes concernant le réfrigérant utilisé

Ce produit contient des gaz à effet de serre fluorés encadrés par le protocole de Kyoto. Ne libérez pas ces gaz dans l'atmosphère.

Type de réfrigérant : R32

Valeur GWP(1) : 675, Valeur basée sur le 4ème rapport du GIEC.

La quantité de réfrigérant basée sur la réglementation F Gaz 517/2014 est indiquée sur la plaque signalétique de l'unité.

Des inspections périodiques de fuite de réfrigérant peuvent être exigées en fonction de la législation européenne ou local. Veuillez contacter votre distributeur local pour plus d'informations.

(1) Potentiel de réchauffement global

2. CARACTÉRISTIQUES TECHNIQUES

2.1 Données techniques de la pompe à chaleur

Modèles	S.LINE PRO	HP5081DT3LV	HP5111DT3LV	HP5151DT3LV
Tension d'alimentation	V	220V-240V ~ / 1ph / 50Hz		
Réfrigérant	/	R32		
Charge	kg	0,45	0,50	0,65
Masse en teqCO ₂	/	0,30	0,34	0,44
Fréquence du contrôle de fuite	/	Aucune exigence mais conseillé de façon annuelle		
Capacité de chauffage Min--Max ^(a)	kW	2,83 -- 8,16	1,95 -- 10,90	5,27 -- 15,66
Puissance électrique absorbée Min--Max ^(a)	kW	0,212 -- 1,19	0,150 -- 1,92	0,457 -- 2,80
Courant nominal de service Min--Max ^(a)	A	1,41 -- 5,20	1,05 -- 8,49	2,04 -- 12,28
COP Max--Min ^(a)	/	13,30 -- 6,81	12,92 -- 5,67	11,53 -- 5,59
Capacité de chauffage Min--Max ^(b)	kW	1,77 -- 5,91	1,86 -- 8,40	3,81 -- 11,67
Puissance électrique absorbée Min--Max ^(b)	kW	0,31 -- 1,28	0,30 -- 1,83	0,588 -- 2,71
COP Max--Min ^(b)	/	5,70 -- 4,62	6,20 -- 4,59	6,48 -- 4,31
Courant maximum de service (CMS)	A	6,50	10,30	14
Calibre du fusible	gG	10	12	16
Disjoncteur courbe C	C	10	12	16
Courant de démarrage	A	< CMS		
Raccordement hydraulique	mm	50 mm		
Débit d'eau nominal ^(a)	m ³ /h	3,50	4,60	6,70
Perte de charge sur l'eau max	kPa	8	5	10
Compresseur	/	DC Inverter MITSUBISHI ELECTRIC		DC Inverter Mitsubishi
Type	/	Double Rotatif		Double Rotatif
Quantité	/	1		1
Résistance d'enroulement à 20°C	Ohm	1,91 +/- 5%		0,95 +/- 5%
Ventilateur	/	Axial		
Quantité	/	1		
Diamètre	mm	405	500	
Nombre de pale	/	3		
Moteur	/	DC Inverter		
Quantité	/	1		
Vitesse de rotation	Tr/min	500 -- 800	500 -- 900	500 -- 750
Vitesse Mode Silence	Tr/min	500	500	500
Niveau de pression acoustique à 1 m	dB(A)	45,1	48,6	54,1
Niveau de pression acoustique à 10 m	dB(A)	27,9	31,6	36,9
Dimensions nettes de l'unité (L-I-H)	mm	1011 / 430 / 622		1025 / 480 / 768
Poids	kg	61	61	87



(a) Air sec 27°C - Humidité relative 78% - Température d'entrée d'eau 26°C.

(b) Air sec 15°C - Humidité relative 71% - Température d'entrée d'eau 26°C

2. CARACTÉRISTIQUES TECHNIQUES (suite)

2.2 Plage de fonctionnement

Utiliser la pompe à chaleur dans les plages suivantes de températures et d'humidité pour assurer un fonctionnement sûr et efficace.

	Mode chauffage 	Mode Refroidissement 
Température extérieure	-7°C – +35°C	+7°C – +43°C
Température d'eau	+12°C – +32°C	+8°C – +40°C
Humidité relative	< 80%	< 80%
Plage de réglage point de consigne	+15°C – +32°C	+8°C – +32°C



Si la température ou l'humidité ne correspond pas à ces conditions, des dispositifs de sécurité peuvent se déclencher et la pompe à chaleur peut ne plus fonctionner.



La température maximum de chauffage est limitée à +32°C afin d'éviter la détérioration des liners. Hayward décline toutes responsabilités dans le cas d'une utilisation au delà des +32°C.

2. CARACTERISTIQUES TECHNIQUES (suite)

2.3 Dimensions

Modèles :

HP5081DT3LV / HP5111DT3LV / HP5151DT3LV

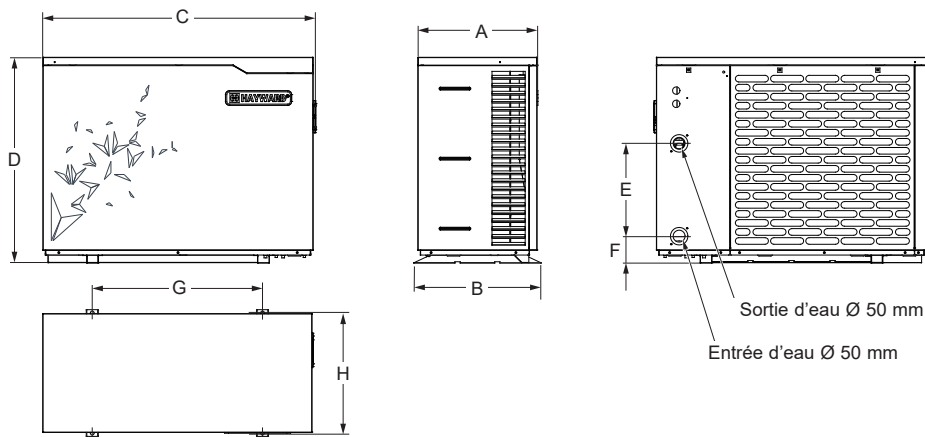

Unité : mm

Repère \ Modèle	HP5081DT3LV / HP5111DT3LV	HP5151DT3LV
A	393	453
B	430	480
C	1011	1030
D	621,5	776
E	350	350
F	97,5	102
G	625	645
H	406	456

3. INSTALLATION ET RACCORDEMENT

3.1 Schéma de principe

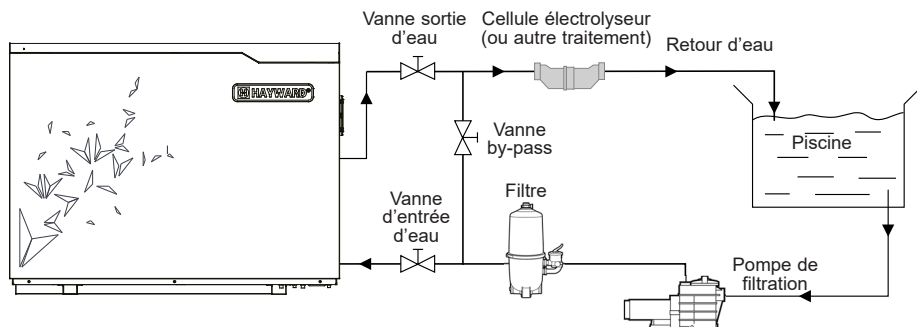

Note : La pompe à chaleur est fournie sans aucun équipement de traitement ou de filtration. Les éléments présentés sur le schéma sont des pièces à fournir par l'installateur.

3.2 Pompe à chaleur



Placer la pompe à chaleur à l'extérieur et en dehors de tout local technique fermé.

Placée sous abri, les distances minimum prescrites ci-dessous doivent être respectées afin d'éviter tout risque de recirculation d'air et une dégradation des performances globales de la pompe à chaleur.

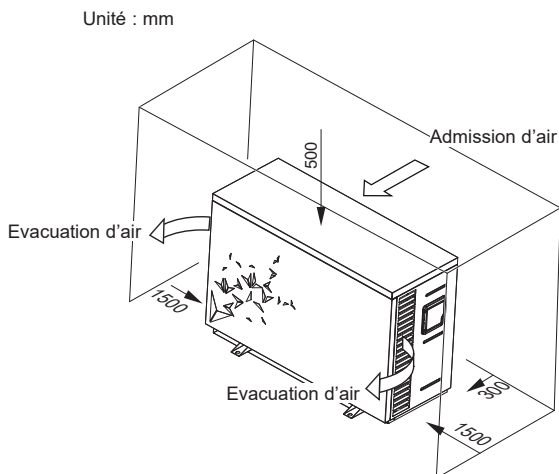

3. INSTALLATION ET RACCORDEMENT (suite)



Installer de préférence la pompe à chaleur sur une dalle béton désolidarisée ou une chaise de fixation prévue à cet effet et monter la pompe à chaleur sur les silentblochs fournis (visserie et rondelles non fournies).

Distance maximale d'installation entre la pompe à chaleur et la piscine 15 mètres.

*Longueur totale aller-retour des canalisations hydrauliques 30 mètres.
Isoler les canalisations hydrauliques de surface et enterrées.*

La pompe à chaleur doit être installée à une distance minimum du bassin conformément à la NF C 15-100 (soit à 3,5 m du plan d'eau pour la France) ou conformément aux normes d'installation en vigueur dans les autres pays.

Ne pas installer la pompe à chaleur à proximité d'une source de chaleur.

En cas d'installation dans des régions neigeuses il est conseillé d'abriter la machine afin d'éviter une accumulation de neige sur l'évaporateur.

3.3 Raccordement hydraulique

La pompe à chaleur est fournie avec deux raccords union Ø 50 mm. Utiliser du tube PVC pour canalisation hydraulique Ø 50 mm. Raccorder l'entrée d'eau de la pompe à chaleur à la conduite venant du groupe de filtration puis raccorder la sortie d'eau de la pompe à chaleur à la conduite d'eau allant au bassin (cf schéma ci-dessous).

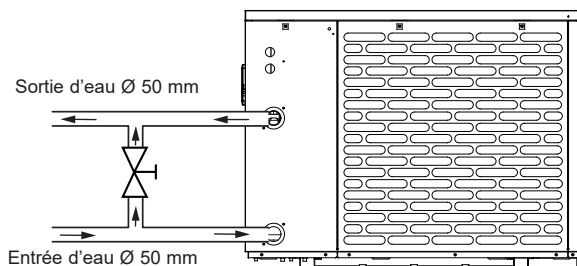

Installer une vanne dite "by-pass" entre l'entrée et la sortie de la pompe à chaleur.



Si un distributeur automatique ou un électrolyseur est utilisé, il doit impérativement être installé après la pompe à chaleur dans le but de protéger le condenseur Titane contre une concentration trop importante de produit chimique.



Veillez à bien installer la vanne by-pass et les raccords union fournis au niveau de l'entrée et de la sortie d'eau de l'unité, afin de simplifier la purge durant la période hivernale, d'en faciliter l'accès ou son démontage pour l'entretien.

3. INSTALLATION ET RACCORDEMENT (suite)

3.4 Raccordement électrique



L'installation électrique et le câblage de cet équipement doivent être conformes aux règles d'installation locales en vigueur.

F	NF C15-100	GB	BS7671:1992
D	DIN VDE 0100-702	EW	EVHS-HD 384-7-702
A	ÖVE 8001-4-702	H	MSZ 2364-702/1994/MSZ 10-553 1/1990
E	UNE 20460-7-702 1993, RECBT ITC-BT-31 2002	M	MSA HD 384-7-702.S2
IRL	Wiring Rules + IS HD 384-7-702	PL	PN-IEC 60364-7-702:1999
I	CEI 64-8/7	CZ	CSN 33 2000 7-702
LUX	384-7.702 S2	SK	STN 33 2000-7-702
NL	NEN 1010-7-702	SLO	SIST HD 384-7-702.S2
P	RSIUEE	TR	TS IEC 60364-7-702



Vérifiez que l'alimentation électrique disponible et la fréquence du réseau correspondent au courant de fonctionnement requis, en prenant en considération l'emplacement spécifique de l'appareil, et le courant nécessaire pour alimenter tout autre appareil connecté au même circuit.

HP5081DT3LV / HP5111DT3LV / HP5151DT3LV
230V ~ +/- 10 % 50 Hz 1 Phase

Observez le schéma de câblage correspondant en annexe.
Trois connexions sont destinées à l'alimentation électrique, et deux à la commande de la pompe de filtration (Asservissement).

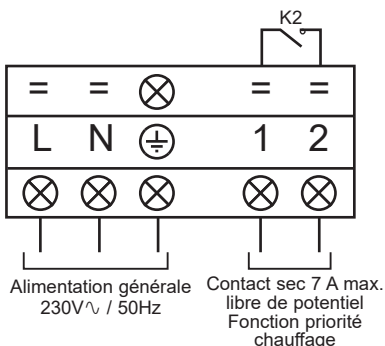

3. INSTALLATION ET RACCORDEMENT (suite)



La ligne d'alimentation électrique doit être dotée, de manière appropriée, d'un dispositif de protection fusible de type alimentation moteur (gG) ou disjoncteur courbe C ainsi que d'un disjoncteur différentiel 30 mA (voir tableau ci-dessous).

Modèles		HP5081DT3LV	HP5111DT3LV	HP5151DT3LV
Alimentation électrique	V/Ph/ Hz	230V~ 50Hz	230V~ 50Hz	230V~ 50Hz
Calibre fusible type gG	A	10 gG	12 gG	16 gG
Disjoncteur courbe C	A	10 C	12 C	16 C
Section de câble	mm ²	3G 2,5	3G 2,5	3G 2,5



Utiliser un câble d'alimentation Type RO2V/R2V ou équivalent.



Les sections de câble sont données pour une longueur maximum de 25 m, elles doivent néanmoins être vérifiées et adaptées en fonction des conditions d'installation.



Prenez toujours garde d'arrêter l'alimentation principale avant d'ouvrir la boîte de commande électrique.

3.5 Premier démarrage

Procédure de démarrage - une fois l'installation terminée, suivez et respectez les étapes suivantes :

- 1) Faites pivoter les ventilateurs à la main afin de vérifier qu'il peut tourner librement, et que l'hélice est fixée correctement sur l'arbre du moteur.
- 2) Assurez-vous que l'unité est connectée correctement à l'alimentation principale (voir le schéma de câblage en annexe).
- 3) Activez la pompe de filtration.
- 4) Vérifiez que toutes les vannes d'eau sont ouvertes, et que l'eau s'écoule vers l'unité avant de passer en mode chauffage ou refroidissement.
- 5) Vérifiez que le tuyau de purge des condensats est fixé correctement, et ne présente aucune obstruction.
- 6) Activez l'alimentation électrique destinée à l'unité, puis appuyez sur le bouton Marche/Arrêt  sur le panneau de commande.
- 7) Assurez-vous que les symboles d'alarme ou de verrouillage ne s'affichent pas. Le cas échéant voir le guide de dépannage (voir § 6.4).

3. INSTALLATION ET RACCORDEMENT (suite)

- 8) Fixez le débit d'eau à l'aide de la vanne by-pass (voir § 2.1 et 4.2), tel que prévu respectivement pour chaque modèle, de manière à obtenir une différence de température Entrée/Sortie de 2°C.
- 9) Après un fonctionnement de quelques minutes, vérifiez que l'air sortant de l'unité s'est refroidi (entre 5°C et 10°C).
- 10) L'unité étant en service, désactivez la pompe de filtration. L'unité doit s'arrêter automatiquement et afficher le code d'erreur E03 (voir § 6.4).
- 11) Faites fonctionner l'unité et la pompe de la piscine 24 heures sur 24, jusqu'à ce que la température de l'eau souhaitée soit atteinte. Quand la température d'entrée d'eau atteint la valeur de consigne, l'unité s'arrête. Elle redémarre alors automatiquement (tant que la pompe de la piscine est en service) si la température de la piscine est inférieure d'au moins 0.5°C à la température de consigne.

Contrôleur de débit - L'unité est dotée d'un contrôleur de débit qui active la pompe à chaleur lorsque la pompe de filtration de la piscine est en service, et la désactive lorsque la pompe de la filtration est hors service. Par manque d'eau, le code d'alarme E03 s'affiche sur le régulateur (Voir § 6.4).

Temporisation - l'unité intègre une temporisation de 3 minutes, afin de protéger les composants du circuit de commande, d'éliminer toute instabilité en terme de redémarrage et, toute interférence au niveau du contacteur. Grâce à cette temporisation, l'unité redémarre automatiquement 3 minutes environ après toute coupure du circuit de commande. Même une coupure de courant de courte durée active la temporisation de démarrage.

4. INTERFACE UTILISATEUR

4.1 Présentation générale

La pompe à chaleur est équipée d'un panneau de commande digital à écran tactile, raccordé électriquement et pré-réglé en usine en mode chauffage.

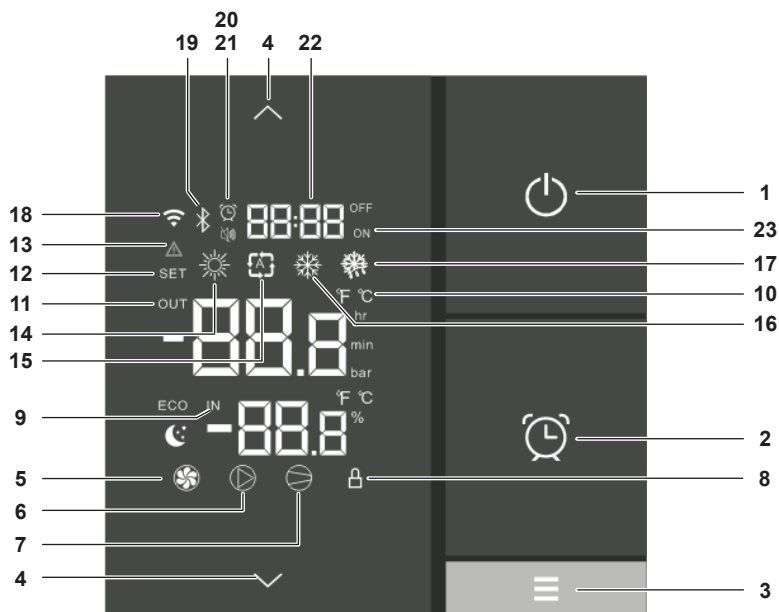

Légende

1		Marche / Arrêt / Annulation
2		Réglage Heure et Timers
3		Choix mode de fonctionnement
4		Défilement Haut / Bas, +°C / -°C
5		Ventilateur ON
6		Contact sec OUT2 ON
7		Compresseur ON
8		Ecran verrouillé
9		Entrée d'eau
10		Celsius / Farenheit
11		Sortie d'eau
12		Réglage paramètres avancés

13		Défaut système
14		Mode chauffage
15		Mode automatique
16		Mode refroidissement
17		Mode dégivrage
18		N/A
19		Connection Bluetooth
20		Timer programmé
21		Témoin mode silence / Timer
22		Heure / Heure des timers
23		Timer programmés en Arrêt et Marche

4. INTERFACE UTILISATEUR (suite)

Mode OFF/ARRET

Lorsque la pompe à chaleur est en veille (Mode OFF), l'inscription OFF est affichée sur l'écran du régulateur et l'écran passe en économie d'énergie au bout d'une minute.

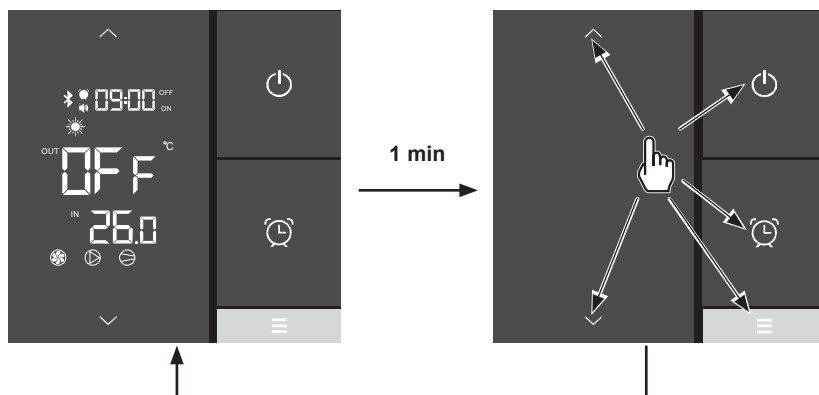

Pour revenir à l'affichage complet, presser sur n'importe quel bouton.

Mode ON

Lorsque la pompe à chaleur est en fonctionnement ou en régulation (Mode ON) les températures d'entrée et de sortie d'eau sont affichées sur l'écran du régulateur et l'écran passe en économie d'énergie au bout d'une minute.

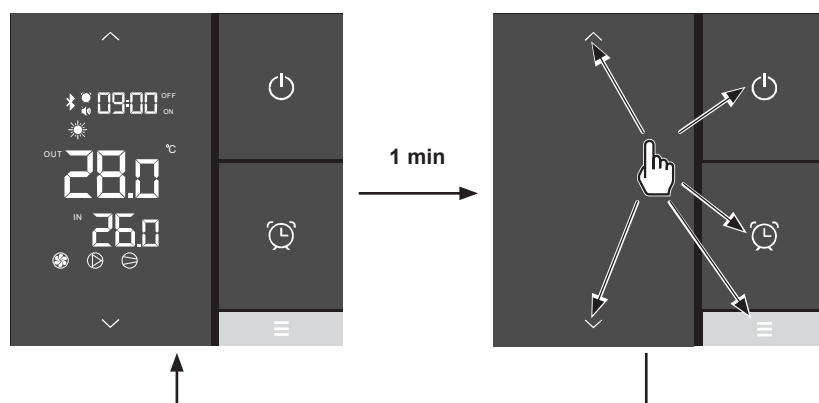

Pour revenir à l'affichage complet, presser sur n'importe quel bouton.

4. INTERFACE UTILISATEUR (suite)

4.2 Réglage du débit d'eau

Les vannes d'entrée et de sortie d'eau étant ouvertes, ajuster la vanne dite "by-pass" de façon à obtenir une différence de 2°C entre la température d'entrée et de sortie d'eau (voir schéma de principe § 3.1).

Vous pouvez vérifier le réglage en visualisant les températures entrée/sortie directement sur le panneau de commande en suivant la procédure ci-dessous.

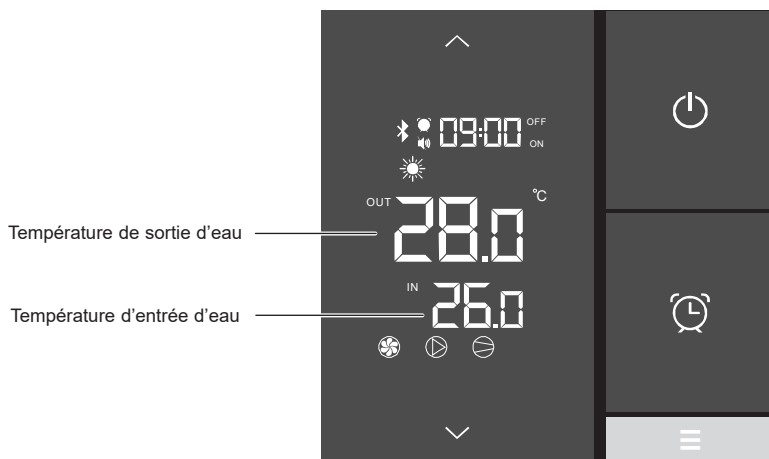

Puis, régler votre By-pass afin d'obtenir une différence de 2°C entre l'entrée et la sortie.

Appuyer sur  pour sortir du menu.

- L'ouverture de la vanne «by-pass» engendre un débit moins important dans l'échangeur de la pompe à chaleur d'où une augmentation de l'écart de température entrée/sortie.
- La fermeture de la vanne «by-pass» engendre un débit plus important dans l'échangeur de la pompe à chaleur d'où une diminution de l'écart de température entrée/sortie.

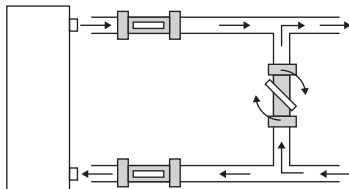

Il est possible de vérifier le réglage en visualisant les températures d'entrée/sortie (1-2) directement sur l'application "EyesPool Inverter Connect" (voir § 4.6).











4. INTERFACE UTILISATEUR (suite)

4.3 Réglage l'horloge

A la fin des réglages, presser sur  pour valider.

L'enregistrement des réglages est automatique au bout de 5 secondes sans action.













- Presser sur  l'affichage de l'heure clignote.
- Presser sur  l'affichage des heures clignote. Régler les heures à l'aide des boutons  et .
- Presser sur  puis régler les minutes à l'aide des boutons  et .
- Valider en pressant sur .

4.4 Réglage des Timers Marche/Arrêt

Le réglage de cette fonction est nécessaire dès lors que vous souhaitez faire fonctionner votre pompe à chaleur sur une plus courte période que celle définie par l'horloge de filtration. Ainsi vous pourrez programmer un départ différé et un arrêt anticipé ou simplement interdire une plage horaire de fonctionnement (par exemple la nuit).

Vous avez la possibilité de programmer un Timer Départ (ON) et un Timer Arrêt (OFF).

Programmation du Timer - Départ (ON)

- Presser  pendant 2 secondes, jusqu'à ce que l'icône  clignote.
- Presser sur , l'affichage  clignote (.
- Presser sur  pour régler les heures à l'aide des boutons  et .
- Presser sur  pour régler les minutes à l'aide des boutons  et .
- Valider en pressant sur  puis sur  pour revenir à l'écran principal.

















La sauvegarde est automatique au bout de 20s sans action.

Le réglage des minutes se fait par tranche de 10 minutes

L'indication ON sous l'affichage de l'heure au niveau de l'écran principal indique que le Timer Départ (ON) est programmé.

4. INTERFACE UTILISATEUR (suite)

Programmation du Timer - Arrêt (OFF)







- Presser  pendant 2 secondes, jusqu'à ce que l'icône  clignote
- Presser sur , l'affichage  clignote ().
- Presser sur , l'affichage  clignote ().
- Presser sur  pour régler les heures à l'aide des boutons  et .
- Presser sur  pour régler les minutes à l'aide des boutons  et .
- Valider en pressant sur  puis sur  pour revenir à l'écran principal.

La sauvegarde est automatique au bout de 20s sans action.

Le réglage des minutes se fait par tranche de 10 minutes





L'indication OFF au dessus de l'affichage de l'heure au niveau de l'écran principal indique que le Timer Arrêt (OFF) est programmé.

Consultation des Timers





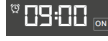

- Presser  pendant 2 secondes, jusqu'à ce que l'icône  clignote.
- Presser sur , l'affichage de l'heure de départ  clignote.
- Presser sur , l'affichage de l'heure d'arrêt  clignote.
- Presser sur  pour revenir à l'écran principal.

L'icône  s'affiche sur l'écran principal lorsqu'un timer Départ et/ou un Timer Arrêt est programmé.

Suppression des Timers Départ (ON) et Arrêt (OFF)











- Presser  pendant 2 secondes, jusqu'à ce que l'icône  clignote.
- Presser 2 fois sur , les heures de départ clignotent .
- Presser sur  pour supprimer le Timer de départ .

A la fin de l'étape 3 presser sur  pour revenir à l'écran principal ou passer à l'étape 4 pour continuer.

- Presser sur  par accéder à l'horaire d'arrêt .
- Presser sur , les heures d'arrêt clignotent .
- Presser sur  pour supprimer le Timer d'arrêt .
- Presser sur  pour revenir à l'écran principal.

4. INTERFACE UTILISATEUR (suite)

















Suppression du Timer Arrêt (OFF)

- Presser  pendant 2 secondes, jusqu'à ce que l'icone  clignote.
- Presser 2 fois sur , les heures de départ clignote .
- Presser sur  pour accéder à l'horaire d'arrêt .
- Presser sur , les heures d'arrêt clignent .
- Presser sur  pour supprimer le Timer d'arrêt .
- Presser sur  pour revenir à l'écran principal.











4.5 Réglage de la fonction Timer en mode SILENCE

Le mode SILENCE permet une utilisation de la pompe à chaleur en mode économique et très silencieux lorsque les besoins de chauffage sont faibles (maintien en température du bassin, ou besoin d'avoir un fonctionnement ultra.

Programmation du Timer en mode SILENCE

- Presser sur  pendant 2 secondes, jusqu'à ce que l'icone  clignote.
- Presser sur , l'icône  clignote.
- Presser sur , l'affichage  clignote.
- Presser sur  pour régler l'heure de départ à l'aide des boutons  et .
- Presser sur  puis sur  l'affichage  clignote.
- Presser sur  pour régler l'heure d'arrêt à l'aide des boutons  et .
- Presser sur  pour valider puis sur  pour revenir à l'écran principal.

Suppression du Timer en mode SILENCE







- Presser sur  pendant 2 secondes, jusqu'à ce que l'icone  clignote.
- Presser sur , l'icône  clignote.
- Presser sur , l'affichage de l'heure de départ  clignote.
- Presser sur , seules les heures clignent.
- Presser sur , l'affichage  clignote.
- Presser sur  pour revenir à l'écran principal.

La suppression du Timer Marche engendre systématiquement la suppression du Timer Arrêt.

Le pas de réglage se fait "d'heure en heure".

4. INTERFACE UTILISATEUR (suite)

Consultation du Timer Mode silence

- Presser sur  pendant 2 secondes, jusqu'à ce que l'icône  clignote.
- Presser sur , l'icône  clignote.
- Presser sur  pour visualiser l'heure de départ.
- Presser sur  pour visualiser l'heure d'arrêt.
- Presser sur  pour revenir à l'écran principal.

Lorsque l'icône  s'affiche sur l'écran principal un Timer Départ ou un Timer Arrêt est programmé pour le mode SILENCE.

4.6 Appairage Bluetooth - Commande à distance

La pompe à chaleur est équipée de la fonction Bluetooth.

Grâce à l'application «*EyesPool Inverter Connect*», vous pourrez utiliser votre smartphone comme une télécommande pour contrôler votre pompe à chaleur dans une limite de 10 m en champ libre.

Pour disposer de cette fonction  **Bluetooth**[®] :

- ▶ Télécharger l'application «*EyesPool Inverter Connect*» gratuitement sur



- ▶ Créer un compte sur l'application.
- ▶ Suivre les instructions de la vidéo (liens ci-dessous) afin de réaliser l'appairage de votre smartphone avec la pompe à chaleur :
<https://www.hayward.fr/article/tutoriels-hayward/s-line-pro-bluetooth-appairage>



4. INTERFACE UTILISATEUR (suite)

4.7 Choix du mode de fonctionnement

Chauffage - Automatique - Refroidissement



Si la pompe à chaleur est réglée en mode Chaud Seul ou Froid Seul par l'installateur, le changement de mode n'est plus disponible.

Presser le bouton  pour changer de mode : Chauffage - Automatique - Refroidissement.

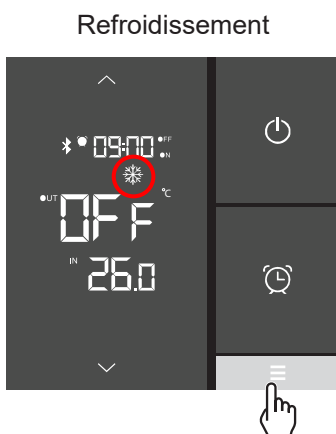
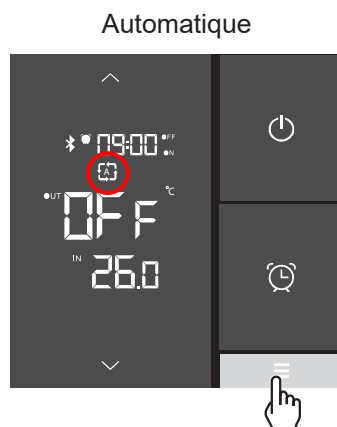
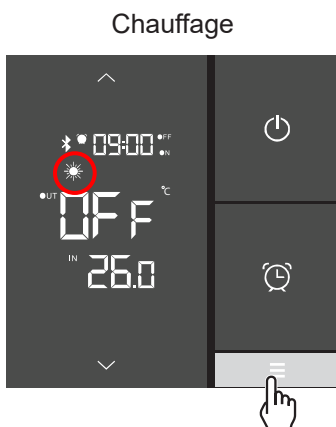





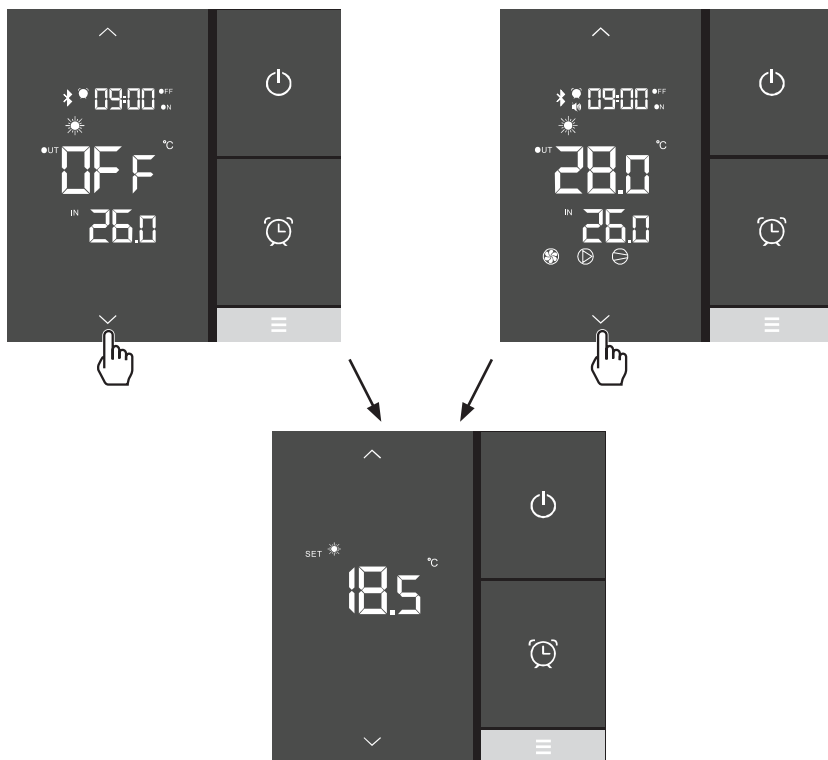

4. INTERFACE UTILISATEUR (suite)

4.8 Réglage et visualisation du point de consigne

Température d'eau souhaitée

Le réglage du point de consigne s'effectue indifféremment en mode OFF ou en mode ON avec une précision de 0,5°C.



- Presser sur  ou  pour faire clignoter le point de consigne.
- Presser sur  ou  pour définir le point de consigne souhaité.
- Presser sur  pour valider ou sur  pour annuler.

Le réglage est sauvegardé automatiquement au bout de 5 secondes sans action.







Il est recommandé de ne jamais dépasser la température de 30°C pour éviter l'altération des liners.

4. INTERFACE UTILISATEUR (suite)

4.9 Verrouillage et déverrouillage de l'écran tactile

Le verrouillage et déverrouillage de l'écran peut se faire indifféremment en mode ON ou en mode OFF.

- Presser sur  pendant 5 secondes jusqu'à l'apparition de l'icône .
- Pour déverrouiller, presser  jusqu'à la disparition de l'icône .

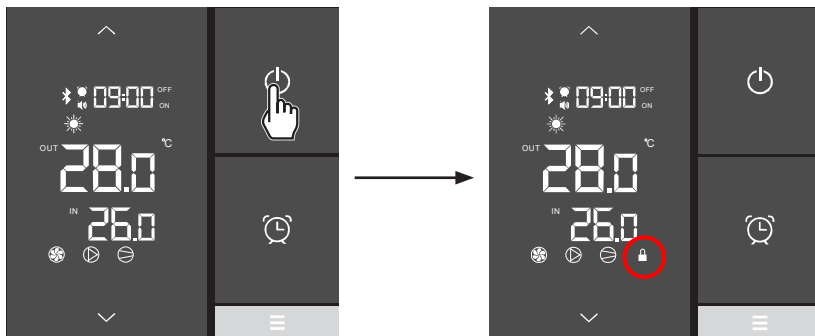

5. ENTRETIEN ET HIVERNAGE

5.1 Entretien

Ces opérations de maintenance doivent être réalisées 1 fois par an afin de garantir la longévité et le bon fonctionnement de la pompe à chaleur.

- Nettoyer l'évaporateur à l'aide d'une brosse souple ou d'un jet d'air ou d'eau (**Attention ne jamais utiliser un nettoyeur haute pression**).
- Vérifier le bon écoulement des condensats.
- Vérifier le serrage des raccords hydrauliques et électriques.
- Vérifier l'étanchéité hydraulique du condenseur.
- Faire vérifier l'étanchéité du circuit frigorifique au détecteur de fuite **par un professionnel agréé**.



Avant toute opération de maintenance la pompe à chaleur doit être déconnectée de toute source de courant électrique. Les opérations de maintenance doivent être réalisées uniquement par un personnel qualifié et habilité à manipuler les fluides frigorigènes.

5.2 Hivernage

- Mettre la pompe à chaleur en Mode "OFF".
- Couper l'alimentation de la pompe à chaleur.
- Vider le condenseur à l'aide de la vidange pour éviter tout risque de dégradation (risque important de gel).
- Fermer la vanne "by-pass" et dévisser les raccords unions entrée/sortie.
- Chasser au maximum l'eau stagnante résiduelle du condenseur à l'aide d'un pistolet à air.
- Obturer l'entrée et la sortie d'eau sur la pompe à chaleur pour éviter l'intrusion de corps étranger.
- Couvrir la pompe à chaleur avec la housse d'hivernage prévue à cet effet.



Tout dommage occasionné par un mauvais hivernage entraîne l'annulation de la garantie.

6. ANNEXES (suite)

HP5151DT3LV

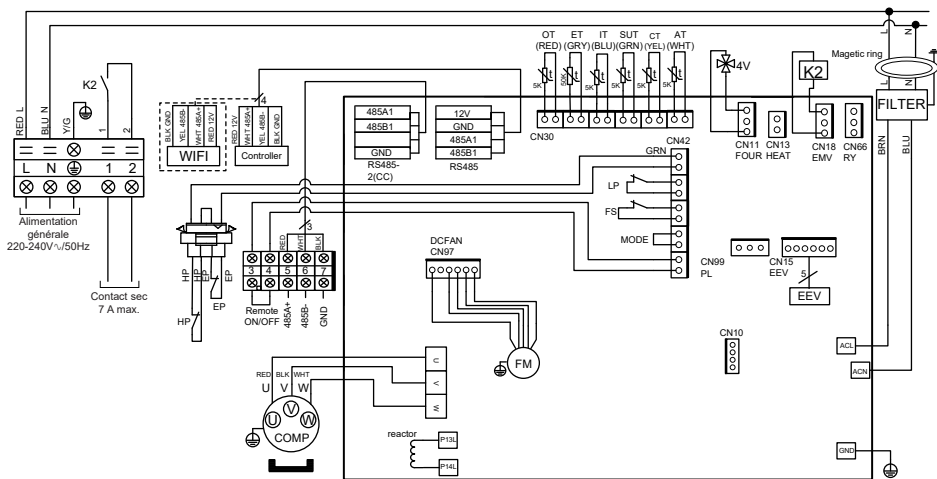

LEGENDE

- | | |
|---|--|
| AT : SONDE DE TEMPÉRATURE D'AIR | LP : PRESSOSTAT BASSE PRESSION |
| COMP : COMPRESSEUR | OHP : PROTECTION THERMIQUE |
| CT : SONDE TEMPÉRATURE ÉVAPORATEUR | OT : SONDE DE TEMPÉRATURE SORTIE D'EAU |
| EEV : DÉTENDEUR ÉLECTRONIQUE | SUT : SONDE DE TEMPÉRATURE D'ASPIRATION |
| FM : MOTEUR VENTILATEUR | 4V : VANNE 4 VOIES |
| FS : DÉTECTEUR PRÉSENCE D'EAU | K2 : CONTACT SEC MAX. 7 A |
| HP : PRESSOSTAT HAUTE PRESSION | ET : SONDE TEMPÉRATURE REFOULEMENT |
| IT : SONDE DE TEMPÉRATURE ENTRÉE D'EAU | OPTION : OPTION |

6. ANNEXES (suite)

6.2 Raccordements priorité chauffage Pompe Monophasé

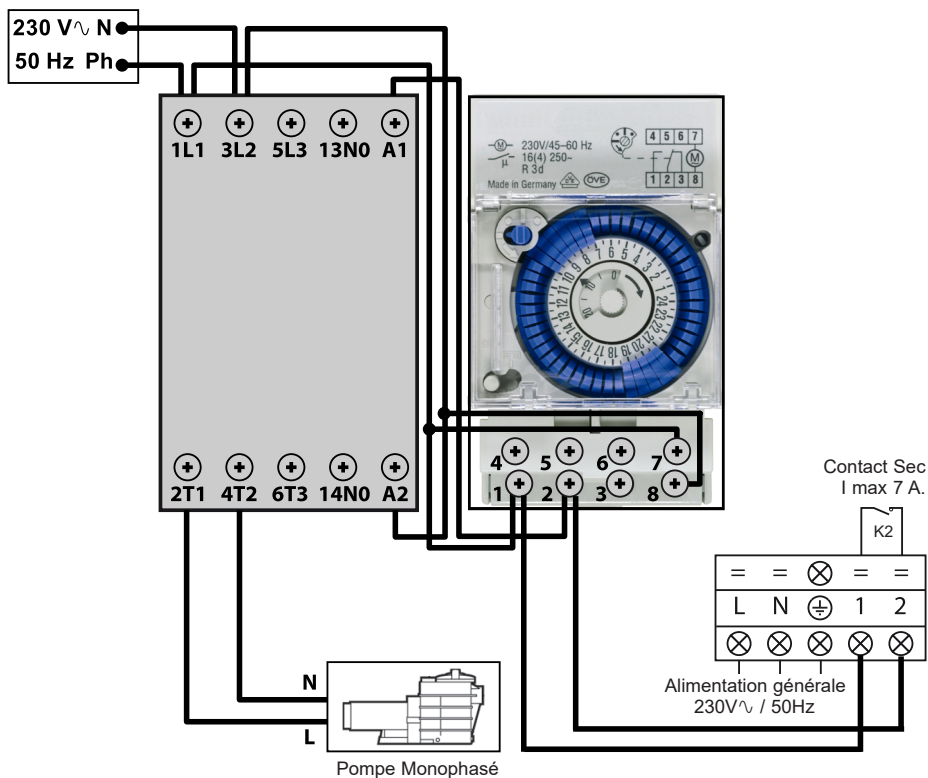

Les bornes 1-2 délivrent un contact sec libre de potentiel, sans polarité 230 V \sim / 50 Hz. Câbler les bornes 1 et 2 en respectant le câblage indiqué ci-dessus afin d'assurer le fonctionnement de la pompe de filtration par cycle de 2 min. toutes les heures si la température du bassin est inférieure au point de consigne.



Ne jamais raccorder l'alimentation de la pompe de filtration directement sur les bornes 1 et 2.

6. ANNEXES (suite)

6.3 Vues éclatées et pièces détachées

HP5081DT3LV / HP5111DT3LV / HP5151DT3LV

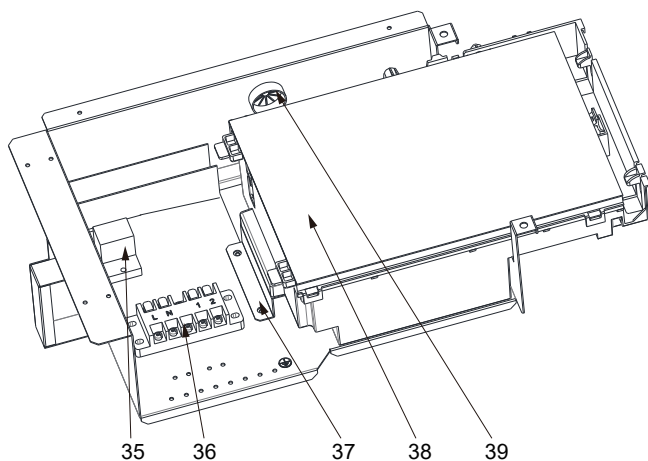
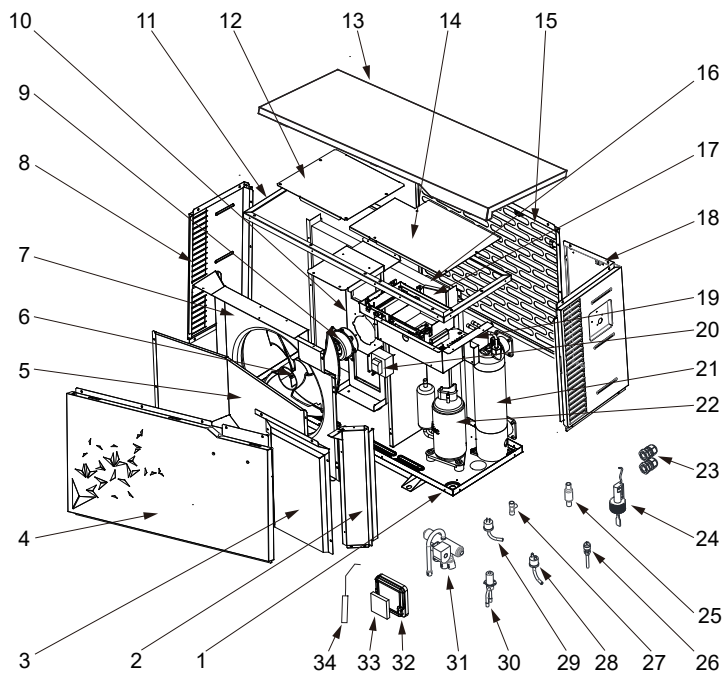

6. ANNEXES (suite)

Rep	Désignation	Réf.	HP5081DT3LV	HP5111DT3LV	HP5151DT3LV
1	/	/	/	/	/
2	/	/	/	/	/
3	/	/	/	/	/
4	Panneau Avant	HWX80715842	✓	✓	n/a
		HWX80715857	n/a	n/a	✓
5	/	/	/	/	/
6	Hélice Ventilateur	HWX301030000006	✓	✓	n/a
		HWX20000270004	n/a	n/a	✓
7	/	/	/	/	/
8	Panneau Gauche	HWX80713420	✓	✓	n/a
		HWX80713423	n/a	n/a	✓
9	Moteur ventilateur DC	HWX80200018	✓	✓	n/a
		HWX20000330132	n/a	n/a	✓
10	Support Moteur	HWX80708597	✓	✓	n/a
		HWX80709977	n/a	n/a	✓
11	/	/	/	/	/
12	/	/	/	/	/
13	Panneau supérieur	HWX80708601	✓	✓	n/a
		HWX80709984	n/a	n/a	✓
14	/	/	/	/	/
15	Panneau Arrière	HWX80710829	✓	✓	n/a
		HWX80710966	n/a	n/a	✓
16	Evaporateur à ailette	HWX80600849	✓	n/a	n/a
		HWX80600781	n/a	✓	n/a
		HWX80600835	n/a	n/a	✓
17	/	/	/	/	/
18	Panneau Droit	HWX80713421	✓	✓	n/a
		HWX80713424	n/a	n/a	✓
19	/	/	/	/	/
20	Réactance	HWX82500020	✓	✓	n/a
		HWX82500021	n/a	n/a	✓
21	Condenseur Titane PVC	HWX80600939	✓	n/a	n/a
		HWX80600940	n/a	✓	✓
		HWX80600096	n/a	n/a	✓
22	Compresseur	HWX20000110448	✓	✓	n/a
		HWX80100046	n/a	n/a	✓
23	Presse Etoupe	HWX20012249	✓	✓	n/a
		HWX20012238	n/a	n/a	✓
24	Détecteur de débit d'eau	HWX83000068	✓	✓	✓
25	Filtre Ø9.7-Ø9.7 (Ø19)	HWX20000140178	✓	✓	n/a
	Filtre Ø9.7-Ø9.7 (Ø28)	HWX20041444	n/a	n/a	✓
26	Prise de pression 40mm-1/2"	HWX20000140150	✓	✓	✓
27	Connecteur T Ø9.52-2 xØ6.35(T) x 1.0	HWX30403000002	✓	✓	n/a
	Connecteur T Ø6.5-2 x Ø6.5(T) x 0.75	HWX20001460	n/a	n/a	✓
28	Pressostat basse pression NO 0.30MPa/0.15MPa	HWX20000360157	✓	✓	✓
29	Pressostat haute pression NC 3.2MPa/4.4MPa	HWX20013605	✓	✓	✓
30	Détendeur électronique	HWX81000011	✓	✓	n/a
		HWX81000017	n/a	n/a	✓
31	Vanne 4 voies	HWX20041437	✓	✓	n/a
		HWX20000140485	n/a	n/a	✓
32	Support Contrôleur	HWX80901004	✓	✓	✓
33	Contrôleur LCD bluetooth	HWX72200312	✓	✓	✓

6. ANNEXES (suite)

HP5081DT3LV / HP5111DT3LV / HP5151DT3LV

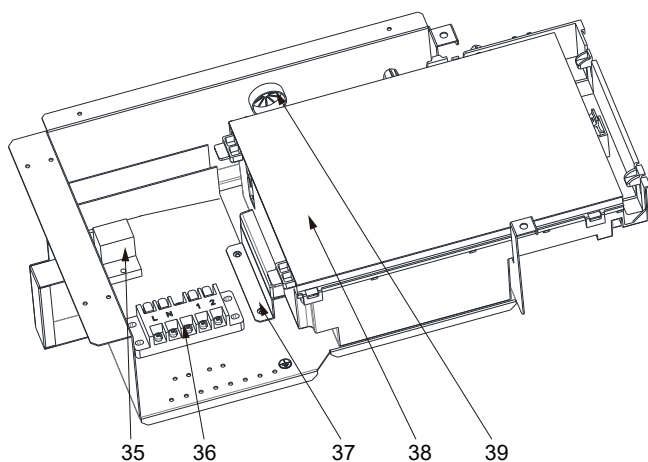
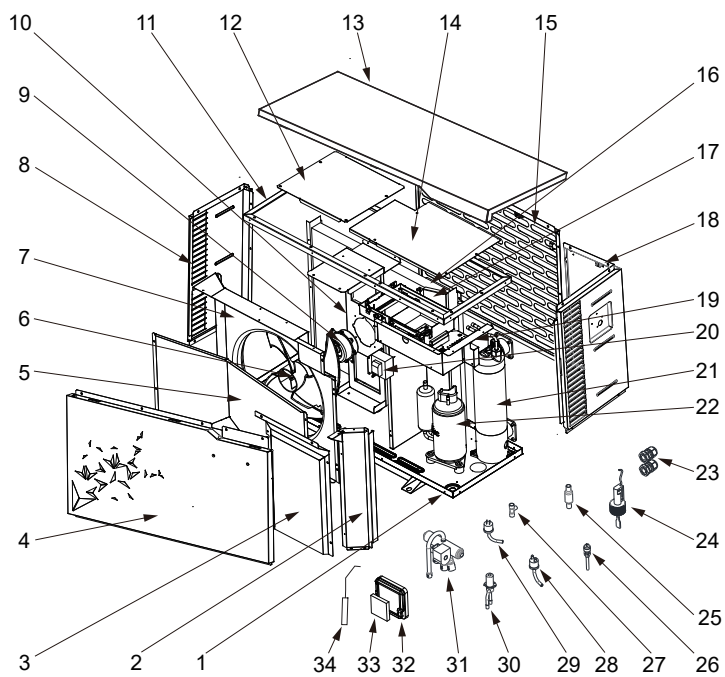

6. ANNEXES (suite)

Rep	Désignation	Réf.	HP5081DT3LV	HP5111DT3LV	HP5151DT3LV
34	Sonde Sortie d'eau 5k-410mm	HWX83000050	✓	✓	✓
	Sonde Entrée d'eau 5k-850mm	HWX83000052	✓	✓	✓
	Sonde Refoulement Compresseur 50k-660mm	HWX83000026	✓	✓	✓
	Sonde Aspiration Compresseur 5k-560mm	HWX83000044	✓	✓	n/a
	Sonde Aspiration Compresseur 5k-760mm	HWX83000053	n/a	n/a	✓
	Sonde de dégivrage 5k-680mm	HWX83000051	✓	✓	n/a
	Sonde de dégivrage 5k-1040mm	HWX83000045	n/a	n/a	✓
	Sonde température Air 5k-350mm	HWX83000049	✓	✓	✓
35	Relais K2	HWX20000360297	✓	✓	✓
36	Bornier L-N-GND -5 connexions 4mm ²	HWX40003901	✓	✓	✓
37	/	/	/	/	/
38	Carte électronique Driver	HWX72200168SL08	✓	n/a	n/a
		HWX72200168SL11	n/a	✓	n/a
		HWX72200168SL15	n/a	n/a	✓
39	/	/	/	/	/

6. ANNEXES (suite)



6.4 Guide de dépannage

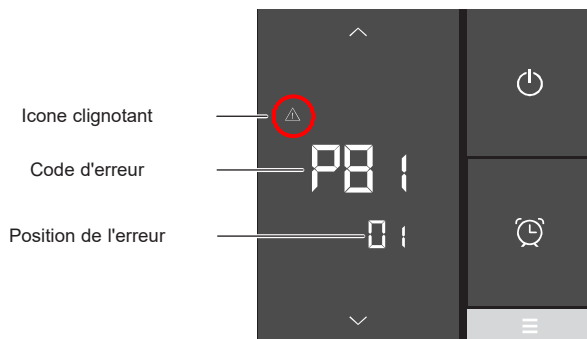

Certaines opérations doivent être réalisées par un technicien habilité.

En cas de défaut, les indications suivantes s'affichent à l'écran :



En cas d'erreur, presser sur  ou  pour faire défiler les codes d'erreur.
Se reporter au tableau ci-après.

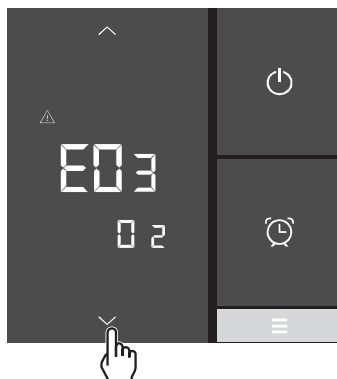

Après résolution du problème l'erreur est acquitée automatiquement, le triangle disparaît.

6. ANNEXES (suite)

Dysfonctionnement	Codes d'erreur	Description	Solution
Défaut sonde entrée d'eau (IT)	P01	Le capteur est ouvert ou en court circuit	Vérifier la connectique sur le connecteur rallonge ou remplacer le capteur
Défaut sonde de sortie d'eau (OT)	P02		
Défaut sonde température extérieure (AT)	P04		
Défaut sonde dégivrage (CT)	P05		
Défaut sonde d'aspiration Compresseur (SUT)	P07		
Défaut sonde de refoulement Compresseur (ET)	P08 1		
Défaut Haute pression	E01	Le capteur est ouvert ou en court circuit	<p>Vérifier la connectique sur le connecteur rallonge ou remplacer le capteur</p> <p>Vérifier le débit d'eau</p> <p>Vérifier le détecteur de débit d'eau</p> <p>Vérifier l'ouverture des vannes</p> <p>Vérifier le by-pass</p> <p>Vérifier l'encrassement de l'évaporateur</p> <p>Température d'eau trop chaude</p> <p>Problème d'incondensable après une maintenance, vider et tirer au vide le circuit frigorifique</p> <p>Charge de fluide trop importante, retirer du fluide dans une bouteille de liquide</p>
Défaut basse pression	E02	Le capteur est ouvert ou en court circuit	<p>Vérifier la connectique sur le connecteur rallonge ou remplacer le capteur</p> <p>Fuite importante de fluide frigorigène, faire une recherche de fuite au détecteur</p> <p>Débit d'air trop faible, vérifier la vitesse de rotation du ventilateur</p> <p>Vérifier l'encrassement de l'évaporateur, nettoyer sa surface</p>

6. ANNEXES (suite)

Dysfonctionnement	Codes d'erreur	Description	Solution
Défaut détecteur de débit	E03	Le capteur est ouvert ou en court circuit	Vérifier la connectique CN29/OVT sur la carte ou remplacer le capteur
			Manque d'eau, vérifier le fonctionnement de la pompe de filtration
			Vérifier l'ouverture des vannes d'arrêts
			Vérifier le réglage du by-pass
Différence de température Entrée/Sortie > 13°C	E06	Applicable en mode Froid seulement	Manque d'eau, vérifier le fonctionnement de la pompe de filtration
			Vérifier l'ouverture des vannes d'arrêts
			Vérifier le réglage du by-pass
Protection Anti-gel	E07	Température de sortie d'eau < 4°C	Stopper la pompe à chaleur, vidanger le condenseur risque de gel
Problème de communication	E08	Pas de communication entre la carte électronique et l'interface utilisateur	Vérifier les raccordements et la connectique - voir schéma électrique
Protection Anti-gel de niveau 1	E19	2°C < Température d'eau < 4°C et Température d'air < 0°C	Arrêter le fonctionnement de la pompe à chaleur, vidanger le condenseur pour éviter le gel, par défaut la pompe à chaleur démarre la pompe de filtration pour éviter la prise en glace
Protection Anti-gel de niveau 2	E29	Températures d'eau < 2°C et Température d'air < 0°C	Arrêter le fonctionnement de la pompe à chaleur, vidanger le condenseur pour éviter le gel, par défaut la pompe à chaleur démarre la pompe de filtration et la pompe à chaleur pour éviter la prise en glace.
Défaut moteur ventilateur	F03 I	Moteur bloqué ou défaut de connexion	Vérifier la libre rotation; vérifier la connectique CN97/DCFan; remplacer le moteur
Défaut moteur ventilateur	F05 I	Défaut de connexion	Vérifier la connectique DCFAN/CN97 ; remplacer le moteur
Température extérieure trop basse	EP	Limite de fonctionnement atteinte	Arrêter la pompe à chaleur
La pompe à chaleur ne démarre pas	- - - OFF	Contact (5-6) Remote On/Off Ouvert	Fermer le contact (5-6) Remote On/Off (voir schéma électrique)

6. ANNEXES (suite)

6.5 Garantie

CONDITIONS DE GARANTIE

Tous les produits HAYWARD sont garantis contre tous vices de fabrication ou de matière pendant une période de deux années à compter de la date d'achat. Toute demande de garantie devra être accompagnée d'une preuve d'achat justifiant sa date. Nous vous incitons donc à conserver votre facture.

La garantie HAYWARD est limitée à la réparation ou au remplacement, au choix d'HAYWARD, des produits défectueux pour autant qu'ils aient subi un emploi normal, en accord avec les prescriptions mentionnées dans leur manuel d'utilisation, que le produit n'ait été modifié d'aucune sorte et utilisé uniquement avec des composants et des pièces HAYWARD. Les dommages dus au gel et aux attaques d'agents chimiques ne sont pas garantis.

Tous les autres frais (transport, main d'œuvre...) sont exclus de la garantie.

HAYWARD ne pourra être tenu pour responsable d'aucun dommage direct ou indirect provenant de l'installation, du raccordement ou du fonctionnement incorrect d'un produit.

Pour faire jouer une garantie et demander la réparation ou le remplacement d'un article, adressez vous à votre revendeur. Aucun retour de matériel à notre usine ne sera accepté sans notre accord écrit préalable.

Les pièces d'usure ne sont pas couvertes par la garantie.

Page laissée blanche intentionnellement



S.Line Pro *Fi*

SWIMMING POOL HEAT PUMP UNIT



Installation & Instruction Manual

CONTENTS

1. PREFACE	1
2. Technical Specifications	4
2.1 Heat pump technical data	4
2.2 Operating range	5
2.3 Dimensions	6
3. INSTALLATION AND CONNECTION	7
3.1 Functional Diagram	7
3.2 Heat pump unit	7
3.3 Hydraulic connection	8
3.4 Electrical connection	9
3.5 Initial start-up	10
4. USER INTERFACE	12
4.1 Overview	12
4.2 Water flow setting	14
4.3 Setting the clock	15
4.4 Setting the On/Off timers	15
4.5 Adjusting the SILENT mode of the Timer function	17
4.6 Bluetooth pairing - Remote control	18
4.7 Operating mode selection	19
4.8 Settings and viewing the setpoint	20
4.9 Locking and unlocking the touch screen	21
5. MAINTENANCE AND WINTERISING	22
5.1 Maintenance	22
5.2 Winterising	22
6. APPENDIX	23
6.1 Electrical diagrams	23
6.2 Heating priority wiring for monophasic pump	25
6.3 Exploded view and spare parts	26
6.4 Troubleshooting guide	30
6.5 Warranty	33

Please read attentively and save for future consultation.

This document must be given to the pool owner and should be kept in a safe place.

1. PREFACE

Thank you for purchasing the Hayward heat pump for swimming pools. The S.LINE PRO heat pump has been designed to strict manufacturing standards meeting the highest levels of quality required.

S.LINE PRO heat pumps offer you exceptional performance throughout your bathing season by adapting wattage, power usage and noise levels to the heating requirements of your swimming pool thanks to FULL INVERTER control logic.



Read the instructions in this manual carefully before using the device.

S.LINE PRO heat pumps are designed exclusively to heat swimming pool water; do not use this equipment for any other purpose.

This manual includes all the necessary information for installation, trouble-shooting and maintenance.

Read this manual carefully before opening the unit or doing any maintenance work on it. The manufacturer of this product shall on no account accept any liability for injury to a user or damage to the unit further to any errors made during installation, trouble-shooting or unnecessary maintenance. It is particularly important to follow the instructions given in this manual at all times.

Otherwise the guarantee will be voided.

1. PREFACE (continued)



Safety instructions



This device contains R32.

Never use a refrigerant other than R32. Any other gaseous body mixed with R32 could cause abnormally high pressure and lead to a failure or pipes bursting and injuring people.

During repairs or maintenance operations, use copper tubes that comply with Standard EN 12375-1 (May 2020) and the European Pressure Equipment Directive 97/23 / EC.

As the heat pump is pressurized, never pierce the pipes or attempt any brazing. There is a risk of explosion.

Never expose the device to flames, sparks or other sources of ignition. It could explode and cause serious or even fatal injuries.



The heat pump is designed exclusively for installation outside buildings.

- If kept in storage, the heat pump should be kept in a well-ventilated room with a floor area of more than A_{\min} (m²) as calculated by the following formula:
$$A_{\min} = (M / (2.5 \times 0.22759 \times h_0))^2$$

M is the quantity of refrigerant in the device in kg, and h₀ is the storage height. If stored on the floor, h₀ = 0.6 m.
- The unit must be installed by qualified personnel.
- Do not install the heat pump on a support that risks intensifying the unit's vibrations.
- Make sure the support provided for the unit is strong enough to bear the weight of the unit.
- Do not install the heat pump anywhere liable to amplify its noise level or anywhere where its noise could disturb neighbours.
- All the electrical connections must be fitted by a professional qualified electrician in accordance with the standards in force in the country of installation, see §3.4.
- Shut off the main power supply and disconnecting switch before doing any electrical work. Forgetting to do so could cause electrocution.
- Before installing the unit, check that the earth cable is not cut or disconnected.

1. PREFACE (continued)

- Connect and properly tighten the power cable. A loose connection could damage electrical components.
- Exposing the heat pump to water or a humid atmosphere could cause electrocution. Be very careful.
- If you detect a fault or any abnormal situation, do not install the heat pump and contact your dealer immediately.
- All maintenance work should be done at the recommended intervals, as specified in this manual.
- Repairs must be carried out by qualified personnel.
- Only use OEM spare parts.
- Never use a cleaning method other than the one recommended in this manual.

Important information concerning the refrigerant used

This makes contains fluorinated greenhouse gases regulated by the Kyoto protocol. Do not release these gases into the atmosphere.

Type of refrigerant: R32

GWP(1) value: 675, based in the 4th report of the IPCC.

The quantity of refrigerant, based on the F-Gas regulation no. 517/2014, is stated on the unit's rating plate.

Period checks for leaks of refrigerant may be required by European or local legislation. Please contact your local dealer for more information.

(1) Global warming potential

2. TECHNICAL SPECIFICATIONS

2.1 Heat pump technical data

Models	S.LINE PRO	HP5081DT3LV	HP5111DT3LV	HP5151DT3LV
Supply voltage	V	220V-240V ~/1ph/50Hz		
Refrigerant	/	R32		
Load	kg	0.45	0.50	0.65
Mass in teqCO ₂	/	0.30	0.34	0.44
Leak check frequency	/	No specific frequency. but an annual check is recommended		
Min--Max heating capacity ^(a)	kW	2.83 -- 8.16	1.95 -- 10.90	5.27 -- 15.66
Min--Max electric input power ^(a)	kW	0.212 -- 1.19	0.150 -- 1.92	0.457 -- 2.80
Min--Max continuous current rating ^(a)	A	1.41 -- 5.20	1.05 -- 8.49	2.04 -- 12.28
Max--Min continuous power (COP) ^(a)	/	13.30 -- 6.81	12.92 -- 5.67	11.53 -- 5.59
Min--Max heating capacity ^(b)	kW	1.77 -- 5.91	1.86 -- 8.40	3.81 -- 11.67
Min--Max electric input power ^(b)	kW	0.31 -- 1.28	0.30 -- 1.83	0.588 -- 2.71
Max--Min continuous power (COP) ^(b)	/	5.70 -- 4.62	6.20 -- 4.59	6.48 -- 4.31
Maximum continuous current	A	6.50	10.30	14
Fuse rating	gG	10	12	16
Circuit-breaker curve C	C	10	12	16
Starting current	A	< maximum continuous current		
Hydraulic connection	mm	50 mm		
Nominal water flow ^(a)	m ³ /h	3.50	4.60	6.70
Max. loss of head on water	kPa	8	5	10
Compressor	/	DC Inverter MITSUBISHI ELECTRIC		DC Inverter Mitsubishi
Type	/	Twin rotary		Twin rotary
Quantity	/	1		
Coil resistance at 20°C	Ohm	1.91 +/- 5%		0.95 +/- 5%
Fan	/	Axial		
Quantity	/	1		
Diameter	mm	405	500	
Number of blades	/	3		
Motor	/	DC Inverter		
Quantity	/	1		
Rotation speed	rpm	500 -- 800	500 -- 900	500 -- 750
Silent mode speed	rpm	500	500	500
Sound pressure level at 1 meter	dB(A)	45.1	48.6	54.1
Sound pressure level at 10 meters	dB(A)	27.9	31.6	36.9
Unit's net dimensions (L-W-H)	mm	1011 / 430 / 622		1025 / 480 / 768
Weight	kg	61	61	87



(a) Dry air 27°C - Relative humidity 78% - Water inlet temperature 26°C.

(b) Dry air 15°C - Relative humidity 71% - Water inlet temperature 26°C

2. TECHNICAL SPECIFICATIONS (continued)

2.2 Operating range

Use the swimming pool heat pump unit within the following ranges of temperature and humidity to ensure safe and efficient operation.

	Heating mode 	Cooling mode 
Outside temperature	-7°C – +35°C	+7°C – +43°C
Water temperature	+12°C – +32°C	+8°C – +40°C
Relative humidity	< 80%	< 80%
Setting range from the set point	+15°C – +32°C	+8°C – +32°C



If the temperature or humidity does not correspond to these conditions, the security measures could be activated and the swimming pool heat pump unit may no longer work.



The maximum heating temperature is set at 32°C to prevent damage to the liners. Hayward cannot be held responsible if used at a temperature above +32°C.

2. TECHNICAL SPECIFICATIONS (continued)

2.3 Dimensions

Models:

HP5081DT3LV / HP5111DT3LV / HP5151DT3LV

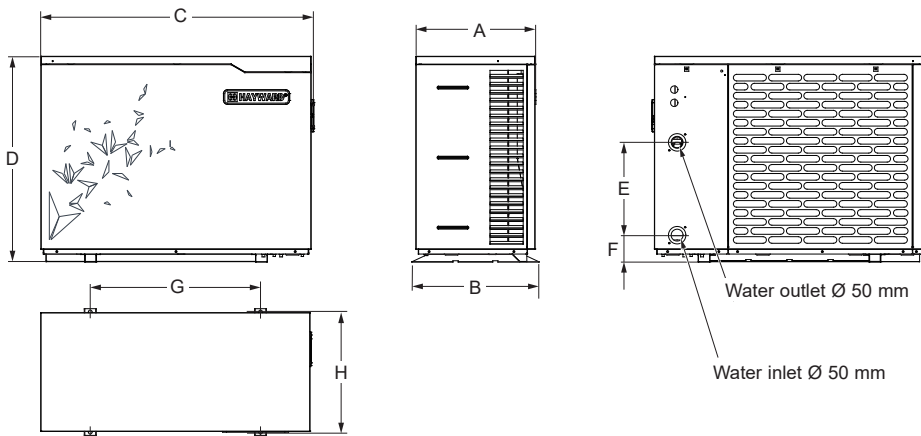

Unit: mm

Size \ Type	HP5081DT3LV / HP5111DT3LV	HP5151DT3LV
A	393	453
B	430	480
C	1011	1030
D	621.5	776
E	350	350
F	97.5	102
G	625	645
H	406	456

3. INSTALLATION AND CONNECTION

3.1 Functional Diagram

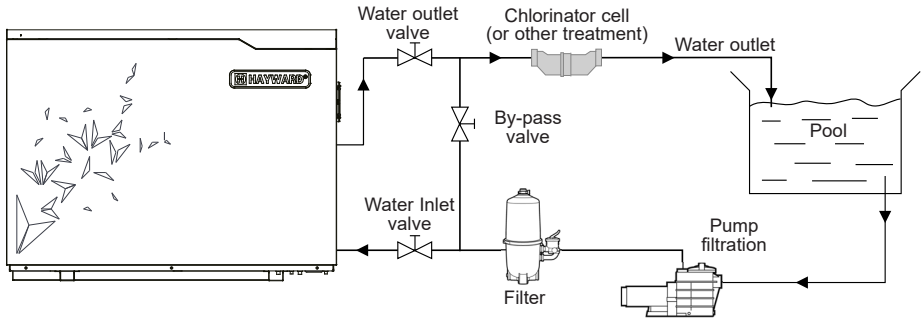

Note: The swimming pool heat pump unit is sold without any treatment or filtration equipment. The components presented in the diagram are spare parts to be supplied by the installer.

3.2 Heat pump unit



Place the heat pump outdoors and away from any enclosed technical space.

Placed under a shelter, the minimum required distances mentioned below must be respected in order to avoid any risk of air recirculation and a deficiency in the unit's overall performance.

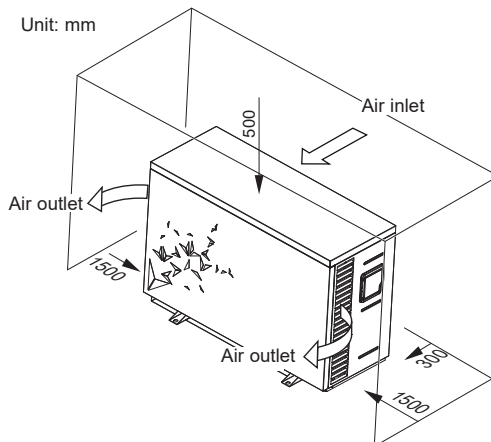

3. INSTALLATION AND CONNECTION (continued)



It is advised to install the unit on a dissociated cement block or a mounting bracket designed for this use and to set up the unit on the supplied rubber bushing (fastenings and washers not supplied).

The maximum installation distance between the unit and the swimming pool is 15 metres.

The total length of the piping to and from the unit is 30 metres.

Insulate both the above ground and buried hydraulic piping.

The heat pump must be installed at a minimum distance from the pool in compliance with NF C 15-100 (3.5 m from the water for France) or in compliance with installation standards applicable in other countries.

Do not install the heat pump close to a heat source.

For installation in snowy regions we recommend sheltering the machine to avoid snow accumulating on the evaporator.

3.3 Hydraulic connection

The unit is supplied with two 50 mm Ø union connections. Connect the water inlet to the heat pump coming from the filtration group then connect the water outlet to the heat pump at the water conduit going to the pool (see diagram below).

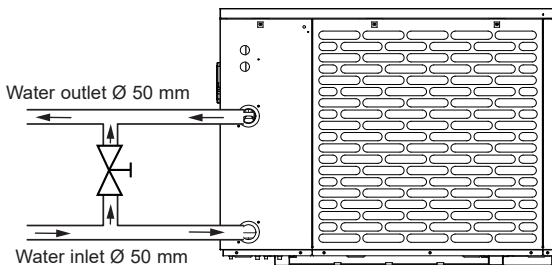

Install a by-pass valve between the heat pump entrance and exit.



If an automatic distributor or an electrolyser is used, it should be installed imperatively after the heat pump with the goal of protecting the titanium condenser against an elevated concentration of chemicals.



Be sure to install the by-pass valve and the supplied union connections at the water inlet and outlet level in order to simplify purging during the winter period and to facilitate access when disassembling for maintenance.

3. INSTALLATION AND CONNECTION (continued)

3.4 Electrical connection



Electrical installation and wiring for this equipment must be in conformity with local installation standards.

F	NF C15-100	GB	BS7671:1992
D	DIN VDE 0100-702	EW	EVHS-HD 384-7-702
A	ÖVE 8001-4-702	H	MSZ 2364-702/1994/MSZ 10-553 1/1990
E	UNE 20460-7-702 1993, RECBT ITC-BT-31 2002	M	MSA HD 384-7-702.S2
IRL	Wiring Rules + IS HD 384-7-702	PL	PN-IEC 60364-7-702:1999
I	CEI 64-8/7	CZ	CSN 33 2000 7-702
LUX	384-7.702 S2	SK	STN 33 2000-7-702
NL	NEN 1010-7-702	SLO	SIST HD 384-7-702.S2
P	RSIUEE	TR	TS IEC 60364-7-702



Verify that the available electrical power supply and the network frequency correspond to the required operating current taking into account the appliance's specific location, and the current required to supply any other appliance connected to the same circuit.

**HP5081DT3LV / HP5111DT3LV / HP5151DT3LV
230V ~ +/- 10 % 50 Hz 1 Phase**

**See the corresponding wiring diagram in the appendix.
Three connections are designed for the power supply and two are for controlling the filter pump (Enslavement).**

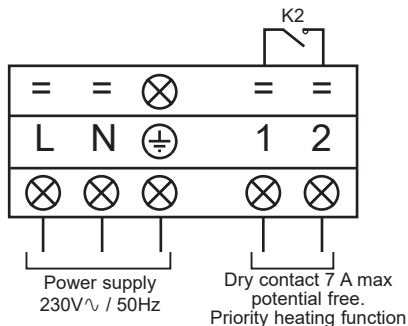

3. INSTALLATION AND CONNECTION (continued)



The electrical power supply must have, when appropriate, a fuse protection device like a feed motor (gG) or C curve circuit breaker as well as a differential circuit breaker 30mA (see following table).

Models		HP5081DT3LV	HP5111DT3LV	HP5151DT3LV
Power supply	V/Ph/ Hz	230V~ 50Hz	230V~ 50Hz	230V~ 50Hz
gG type fuse calibre	A	10 gG	12 gG	16 gG
Curve C circuit breaker	A	10 C	12 C	16 C
Cable section	mm ²	3G 2,5	3G 2,5	3G 2,5



Use an RO 2V/R 2V or equivalent power cord.



The cables sections are given for a maximum length of 25 m. They must however be checked and adjusted according to the installation conditions.



Always shut down the main power supply before opening the electrical control box.

3.5 Initial start-up

Start-up procedure - After installation is complete, follow these steps:

- 1) Rotate the fans by hand to verify that they can turn freely by hand, and that the turbine is correctly affixed to the motor shaft.
- 2) Ensure that the unit is connected correctly to the main power supply (see the wiring diagram in the appendix).
- 3) Activate the filtration pump.
- 4) Verify that all water valves are open and that the water flows toward the unit before switching on the heating or cooling mode.
- 5) Verify that the drainage hose is correctly affixed and that it causes no obstructions.
- 6) Activate the unit power supply, then press the On/Off button  on the control panel.
- 7) Make sure the alarm or lock symbols are not displayed. If need be, see the trouble-shooting guide (see § 6.4).

3. INSTALLATION AND CONNECTION (continued)

- 8) Set the water flow using the by-pass valve (see § 2.1 and 4.2), as provided for by each model, to obtain an Entry/Exit temperature of 2°C.
- 9) After running for several minutes, verify that the air exiting the unit is cool (between 5 and 10°).
- 10) With the unit operating, turn off the filter pump. The unit should automatically turn off and display error code E03 (See § 6.4).
- 11) Allow the unit and the pool pump to run 24 hours per day until the desired water temperature has been reached. When the set water inlet temperature is reached, the unit will turn off. It will automatically restart (as long as the pool pump is running) if the pool temperature is at least 0.5°C below the set temperature.

Water flow switch - The unit is equipped with a flow switch that turns on the heat pump when the pool filtration pump is running, and deactivates it when the filtration pump is out of order. If the water is low, the E03 alarm code will appear on the regulator (See § 6.4).

Time delay - The unit is equipped with a time delay of 3 minutes in order to protect the control circuit components, to eliminate restart cycling and contactor chatter. Thanks to this time delay, the unit automatically restarts approximately 3 minutes after each control circuit interruption. Even a brief power interruption will activate the restart time delay.

4. USER INTERFACE

4.1 Overview

The heat pump is equipped with a digital control panel with a touch screen, electronically connected and pre-set at the factory in heating mode.

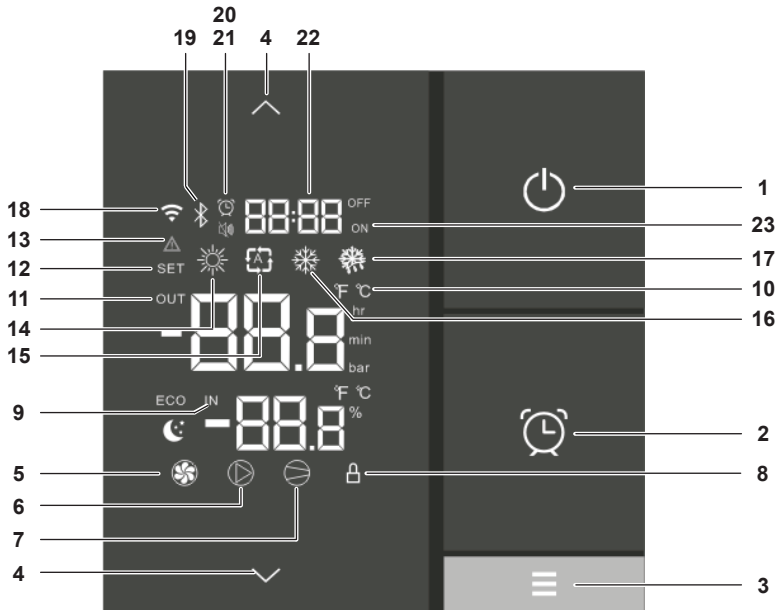

Key

1		On/Off/Back
2		Setting the Time and Timers
3		Operating mode selection
4		Scroll Up / Down, +°C / -°C
5		Fan ON
6		Dry contact OUT2 ON
7		Compressor ON
8		Locked screen
9		Water input
10		Celsius / Fahrenheit
11		Water output
12		Setting advanced settings

13		System default
14		Heating mode
15		Automatic mode
16		Cooling mode
17		Defrost mode
18		N/A
19		Bluetooth Connection
20		Timer set
21		Silence mode / Timer light
22		Time / Time of timers
23		Timers set for Off and On

4. USER INTERFACE (continued)

OFF mode

When the heat pump is on standby (OFF mode), the indication OFF is displayed on the control screen and the screen switches to save-energy mode after one minute.

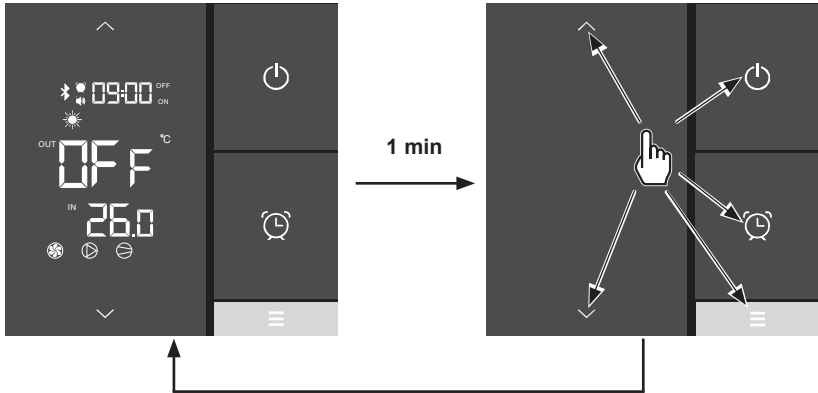

To return to the full display, press any button.

ON mode

When the heat pump is operating or being set (ON mode) the water inflow and outflow temperatures are displayed on the control screen and the screen switches to save-energy mode after one minute.

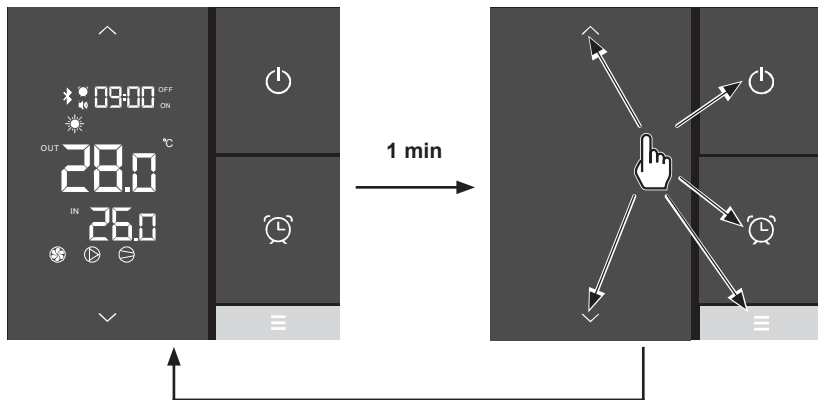

To return to the full display, press any button.

4. USER INTERFACE (continued)

4.2 Water flow setting

With the water entry and exit valves being open, adjust the by-pass valve in order to obtain a difference of 2°C between the water inlet and outlet temperatures (see principle diagram § 3.1).

You can verify the switch by seeing the entry/exit temperatures directly on the control panel.

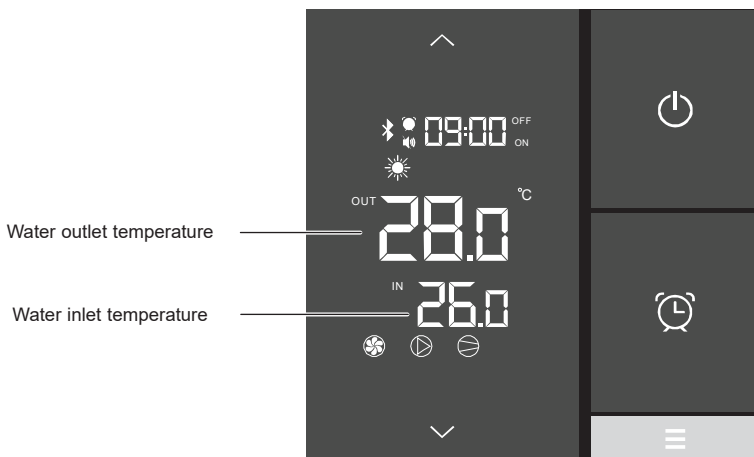

Then, adjust your by-pass in order to obtain a difference of 2°C between the input and the output.

Press  to exit the menu.

- Opening the "bypass" valve generates a lower flow rate in the heat pump exchanger, resulting in an increase in the inlet / outlet temperature difference.
- Closing the "bypass" valve generates a greater flow rate in the heat pump exchanger, resulting in a reduction in the inlet / outlet temperature difference.

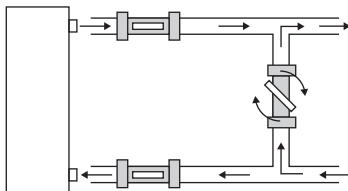









The setting can be checked by viewing the inlet / outlet temperatures (1 - 2) directly on the "EyesPool Inverter Connect" application (see § 4.6).

4. USER INTERFACE (continued)

4.3 Setting the clock

At the end of the settings, press  to confirm.
The saving of the settings is automatic after 5 seconds of inactivity.













- Press : the time display blinks.
- Press : the hours blink. Set the hours using the  and  buttons.
- Press  then set the minutes using the  and  buttons.
- Confirm by pressing .

4.4 Setting the On/Off timers

Setting this function is necessary if you would like to run the heat pump for a shorter period than what is defined by the filtration clock. Therefore, you can program a deferred start and an anticipated stop or simply stop a certain timeframe from running (at night, for example).

It is possible to set one Start Timer (ON) and one Stop Timer (OFF).















Setting the Timer - Start (ON)

- Press  for 2 seconds, until the  icon blinks.
- Press : the  display blinks (.
- Press  to set the hours using the  and  buttons.
- Press  to set the minutes using the  and  buttons.
- Confirm by pressing  then  to return to the main screen.

The settings are saved automatically after 20s of inactivity.
The setting of the minutes is done in steps of 10 minutes
The ON indication under the time display on the main screen indicates that the Start (ON) Timer is set.

4. USER INTERFACE (continued)

Setting the Timer - Stop (OFF)







- Press  for 2 seconds, until the  icon blinks
- Press : the  display blinks (**ON**).
- Press : the  display blinks (**OFF**).
- Press  to set the hours using the  and  buttons.
- Press  to set the minutes using the  and  buttons.
- Confirm by pressing  then  to return to the main screen.

The settings are saved automatically after 20s of inactivity.

The setting of the minutes is done in steps of 10 minutes







The OFF indication above the time display on the main screen indicates that the Stop (OFF) Timer is set.

Consulting Timers







- Press  for 2 seconds, until the  icon blinks.
- Press : the display of the starting time  blinks.
- Press : the display of the stopping time  blink.
- Press  to return to the main screen.

The  icon is displayed on the main screen when a Start Timer and/or Stop Timer is set.

Deleting Start (ON) and Stop (OFF) Timers











- Press  for 2 seconds, until the  icon blinks.
- Press  twice: the start hours blink .
- Press  to delete the start Timer .

At the end of step 3 press  to go back to the main screen or move on to step 4 to continue.

- Press  to access the stop time .
- Press : the stop hours blink .
- Press  to delete the stop Timer .
- Press  to return to the main screen.

4. USER INTERFACE (continued)

















Deleting the Timer Stop (OFF)

- Press  for 2 seconds, until the  icon blinks.
- Press  twice: the start hours blink .
- Press  to access the stop time .
- Press : the stop hours blink .
- Press  to delete the stop Timer .
- Press  to return to the main screen.









4.5 Adjusting the SILENT mode of the Timer function

SILENCE mode enables the heat pump to be used in economic and very silent mode when the heating needs are low (maintaining the pool temperature or need for ultra-silent operation).

Setting the SILENT mode of the Timer

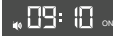
- Press  for 2 seconds, until the  icon blinks.
- Press : the  icon blinks.
- Press : the  display blinks.
- Press  to set the starting time using the  and  buttons.
- Press  then : the  display blinks.
- Press  to set the stop time using the  and  buttons.
- Press  to confirm then  to return to the main screen.

Deleting the SILENT mode of the Timer







- Press  for 2 seconds, until the  icon blinks.
- Press : the  icon blinks.
- Press : the display of the starting time  blinks.
- Press : only the hours blink.
- Press : the  display blinks.
- Press  to return to the main screen.

The deletion of the Start Timer systematically causes the deletion of the Stop Timer.

The setting step is "hour to hour".

4. USER INTERFACE (continued)

Consulting the SILENT mode Timer

- Press  for 2 seconds, until the  icon blinks.
- Press : the  icon blinks.
- Press  to view the start time.
- Press  to view the stop time.
- Press  to return to the main screen.

The  icon is displayed on the main screen when a Start Timer or Stop Timer is set for the SILENCE mode.

4.6 Bluetooth pairing - Remote control

The heat pump is equipped with the Bluetooth function.

Thanks to the "EyesPool Inverter Connect" application, you can use your smartphone as a remote control to control your heat pump within a limit of 10 m in open space.

To have this function  **Bluetooth** :

- ▶ Download the "*EyesPool Inverter Connect*" application for free from



or



- ▶ Create an account on the application.
- ▶ Follow the video instructions (links below) to pair your smartphone with the heat pump:
<https://www.hayward.fr/article/tutoriels-hayward/s-line-pro-bluetooth-appairage>



4. USER INTERFACE (continued)

4.7 Operating mode selection

Heating - Automatic - Cooling



If the heat pump is set to Heat Only or Cool Only mode by the installer, changing the mode is no longer available.

Press the  button to change the mode: Heating - Automatic - Cooling.

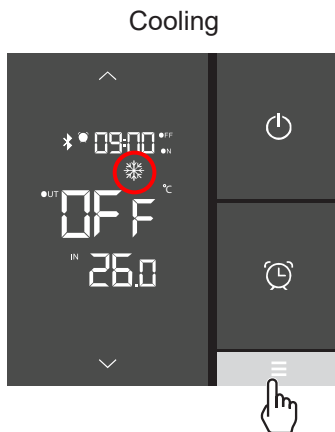
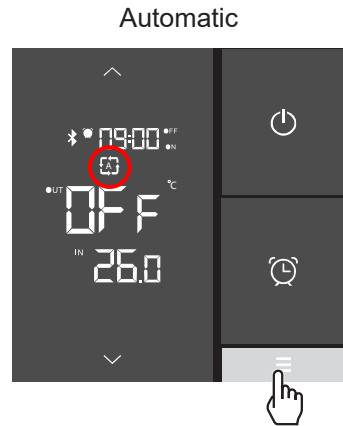
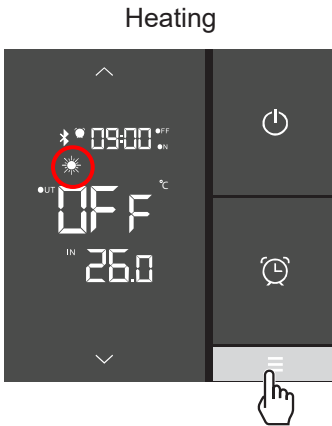

4. USER INTERFACE (continued)

4.8 Settings and viewing the setpoint

Desired water temperature

The setpoint can be changed either in OFF or in ON mode with an accuracy of 0.5°C.

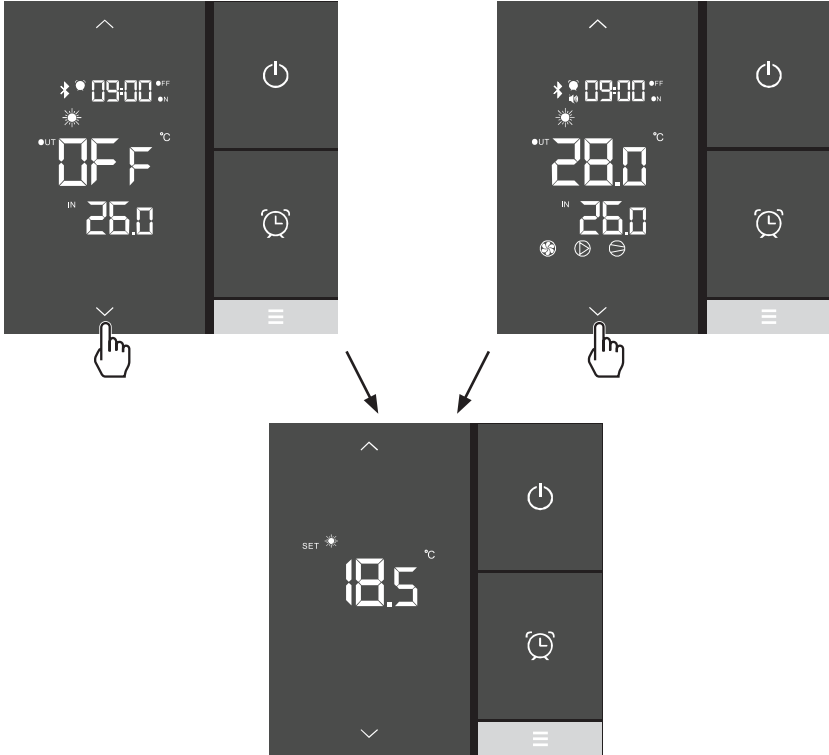

- Press or to make the setpoint blink.
- Press or to set the desired setpoint.
- Press to confirm or to cancel.

The settings are saved automatically after 5 seconds of inactivity.







It is recommended to never exceed 30°C to avoid alteration of the liners.

4. USER INTERFACE (continued)

4.9 Locking and unlocking the touch screen

The screen can be locked or unlocked either in ON or in OFF mode.

- Press  for 5 seconds until the  icon appears.
- To unlock, press  until the  icon disappears.

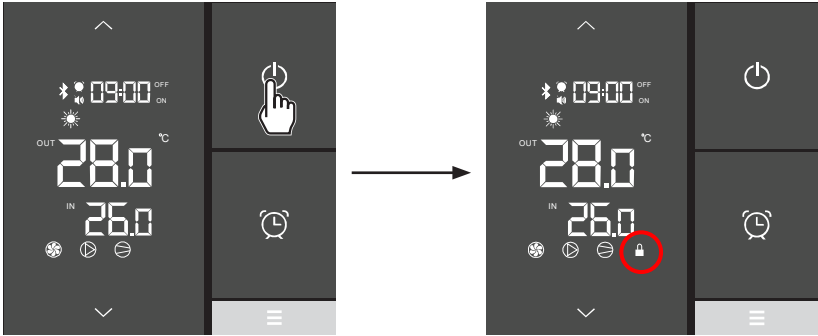

5. MAINTENANCE AND WINTERISING

5.1 Maintenance

These maintenance operations must be carried out once per year in order to guarantee the longevity and the good working condition of the heat pump.

- Clean the coil with the help of a soft brush or jet of air or water (**Warning, never use a high pressure cleaner**).
- Verify that the drains flow well.
- Verify the tightening of the hydraulic and electrical connections
- Verify the hydraulic sealing of the condenser.
- Have the leak-tightness of the cooling circuit to the leak detector checked by an **accredited professional**.



Before any maintenance operation, the heating pump must be disconnected from any electrical current source. The maintenance operations must only be carried out by personnel that is qualified and authorised to handle liquid refrigerants.

5.2 Winterising

- Put the heat pump in “OFF” mode.
- Cut the power supply to the heat pump.
- Empty the condenser with the help of the drain to avoid any risk of deterioration. (high risk of freezing).
- Close the by-pass valve and unscrew the entry/exit connection unions.
- Eliminate the maximum amount of residual stagnant water from the condenser with the help of an air gun.
- Close the water entry and exit areas of the heating pump to avoid introducing foreign bodies.
- Cover the heating pump with a dedicated winterising case.



Any damage caused by poor winterising maintenance will lead to cancellation of the warranty.

6. APPENDIX

6.1 Electrical diagrams

HP5081DT3LVM / HP5111DT3LV

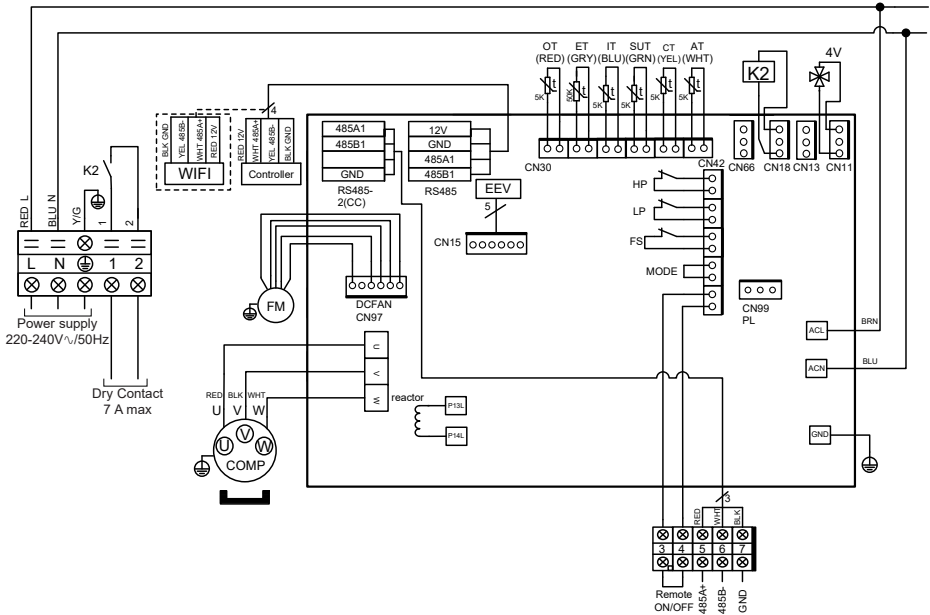

REMARKS

- | | |
|---|--|
| AT: AIR TEMPERATURE SENSOR | LP: LOW PRESSURE SWITCH |
| COMP: COMPRESSOR | OT: OUTLET WATER TEMPERATURE SENSOR |
| CT: EVAPORATOR TEMPERATURE SENSOR | SUT: SUCTION TEMPERATURE SENSOR |
| EEV: ELECTRONIC EXPANSION VALVE | 4V: 4 WAYS VALVE |
| FM: FAN MOTOR | K2: DRY CONTACT 7 A MAX |
| FS: WATER FLOW SWITCH | ET: DISCHARGE TEMPERATURE SENSOR |
| HP: HIGH PRESSURE SWITCH | --- : OPTION |
| IT: WATER INLET TEMPERATURE SENSOR | |

6. APPENDIX (continued)

HP5151DT3LV

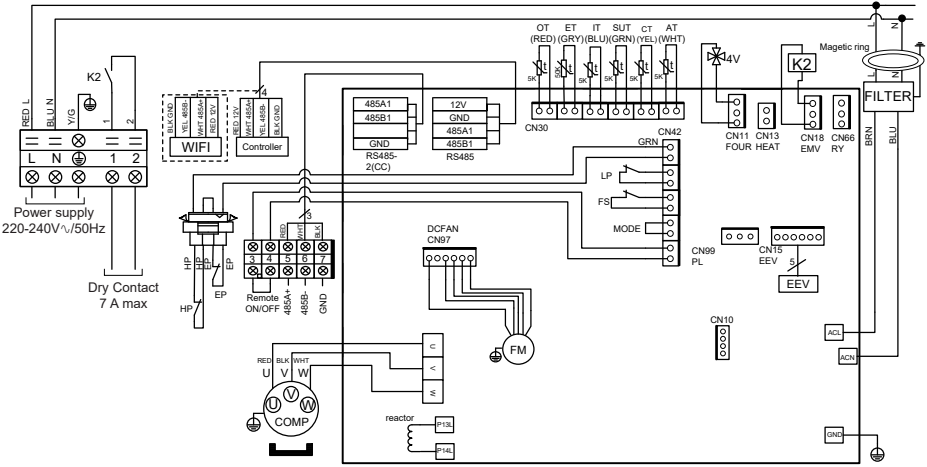

REMARKS

- | | |
|---|--|
| AT: AIR TEMPERATURE SENSOR | LP: LOW PRESSURE SWITCH |
| COMP: COMPRESSOR | OT: OUTLET WATER TEMPERATURE SENSOR |
| CT: EVAPORATOR TEMPERATURE SENSOR | SUT: SUCTION TEMPERATURE SENSOR |
| EEV: ELECTRONIC EXPANSION VALVE | 4V: 4 WAYS VALVE |
| FM: FAN MOTOR | K2: DRY CONTACT 7 A MAX |
| FS: WATER FLOW SWITCH | ET: DISCHARGE TEMPERATURE SENSOR |
| HP: HIGH PRESSURE SWITCH | OPTION: (indicated by a dashed box) |
| IT: WATER INLET TEMPERATURE SENSOR | |

6. APPENDIX (continued)

6.2 Heating priority wiring for monophasic pump

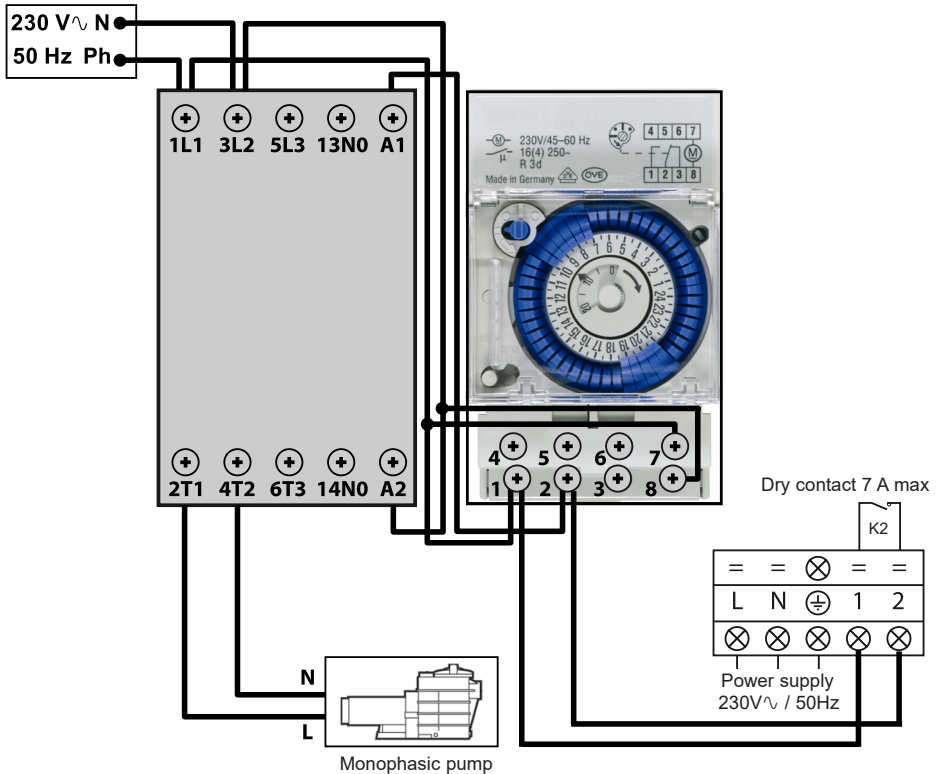

Terminals 1 and 2 deliver a potential-free dry contact, 230V \sim / 50 Hz, no polarity.

Wire terminals 1 and 2 as indicated in the diagram above, to activate the operation of the filtration pump in 2-minute cycles each hour if the temperature of the pool is lower than the set point.



Never connect the power supply of the filtration pump directly to terminals 1 and 2.

6. APPENDIX (continued)

6.3 Exploded view and spare parts

HP5081DT3LV / HP5111DT3LV / HP5151DT3LV

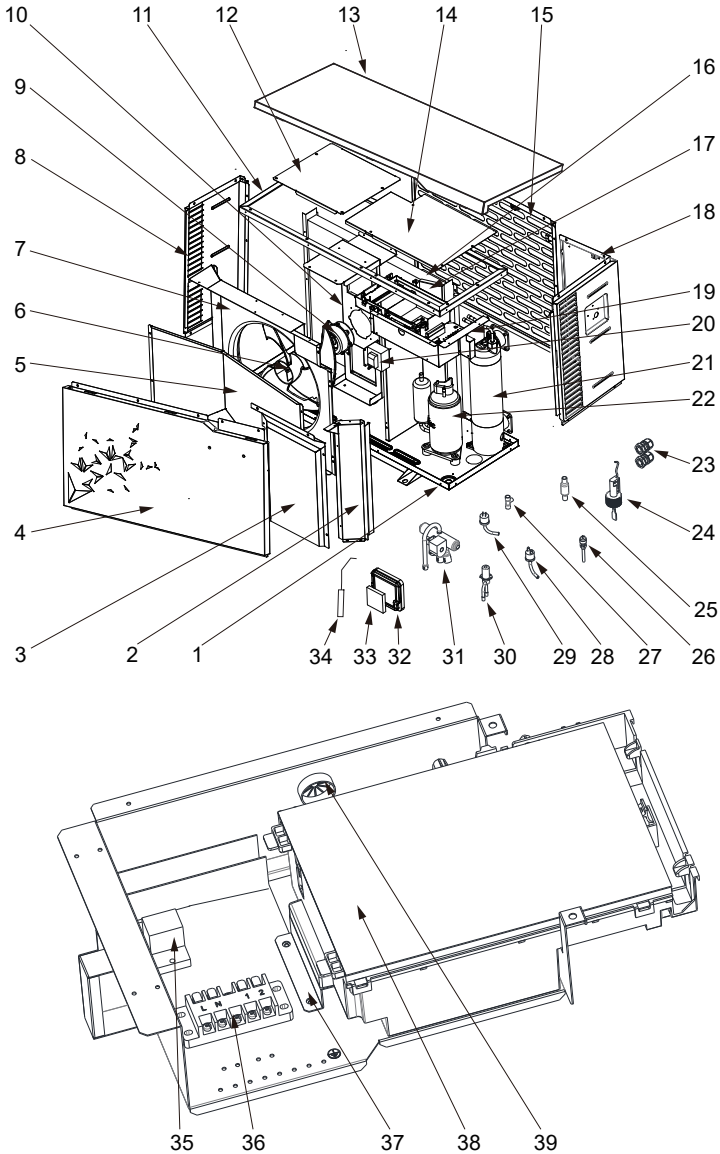

6. APPENDIX (continued)

Mark	Description	Ref.	HP5081DT3LV	HP5111DT3LV	HP5151DT3LV
1	/	/	/	/	/
2	/	/	/	/	/
3	/	/	/	/	/
4	Front panel	HWX80715842	✓	✓	n/a
		HWX80715857	n/a	n/a	✓
5	/	/	/	/	/
6	Fan blade	HWX301030000006	✓	✓	n/a
		HWX20000270004	n/a	n/a	✓
7	/	/	/	/	/
8	Left panel	HWX80713420	✓	✓	n/a
		HWX80713423	n/a	n/a	✓
9	DC ventilator motor	HWX80200018	✓	✓	n/a
		HWX20000330132	n/a	n/a	✓
10	Motor bracket	HWX80708597	✓	✓	n/a
		HWX80709977	n/a	n/a	✓
11	/	/	/	/	/
12	/	/	/	/	/
13	Top cover	HWX80708601	✓	✓	n/a
		HWX80709984	n/a	n/a	✓
14	/	/	/	/	/
15	Back panel	HWX80710829	✓	✓	n/a
		HWX80710966	n/a	n/a	✓
16	Fin coil	HWX80600849	✓	n/a	n/a
		HWX80600781	n/a	✓	n/a
		HWX80600835	n/a	n/a	✓
17	/	/	/	/	/
18	Right panel	HWX80713421	✓	✓	n/a
		HWX80713424	n/a	n/a	✓
19	/	/	/	/	/
20	Reactance	HWX82500020	✓	✓	n/a
		HWX82500021	n/a	n/a	✓
21	Titanium/PVC condenser	HWX80600939	✓	n/a	n/a
		HWX80600940	n/a	✓	✓
		HWX80600096	n/a	n/a	✓
22	Compressor	HWX20000110448	✓	✓	n/a
		HWX80100046	n/a	n/a	✓
23	Cable Gland	HWX20012249	✓	✓	n/a
		HWX20012238	n/a	n/a	✓
24	Water flow detector	HWX83000068	✓	✓	✓
25	Filter Ø9.7-Ø9.7 (Ø19)	HWX20000140178	✓	✓	n/a
	Filter Ø9.7-Ø9.7 (Ø28)	HWX20041444	n/a	n/a	✓
26	Pressure tap 40mm-1/2"	HWX20000140150	✓	✓	✓
27	Connector T Ø9.52-2 xØ6.35(T) x 1.0	HWX30403000002	✓	✓	n/a
	Connector T Ø6.5-2 x Ø6.5(T) x 0.75	HWX20001460	n/a	n/a	✓
28	Low pressure switch NO 0.30MPa/0.15MPa	HWX20000360157	✓	✓	✓
29	High pressure switch NC 3.2MPa/4.4MPa	HWX20013605	✓	✓	✓
30	Electronic expansion valve	HWX81000011	✓	✓	n/a
		HWX81000017	n/a	n/a	✓
31	4 ways valve	HWX20041437	✓	✓	n/a
		HWX20000140485	n/a	n/a	✓
32	Controller mount	HWX80901004	✓	✓	✓
33	LCD Bluetooth controller	HWX72200312	✓	✓	✓

6. APPENDIX (continued)

HP5081DT3LV / HP5111DT3LV / HP5151DT3LV

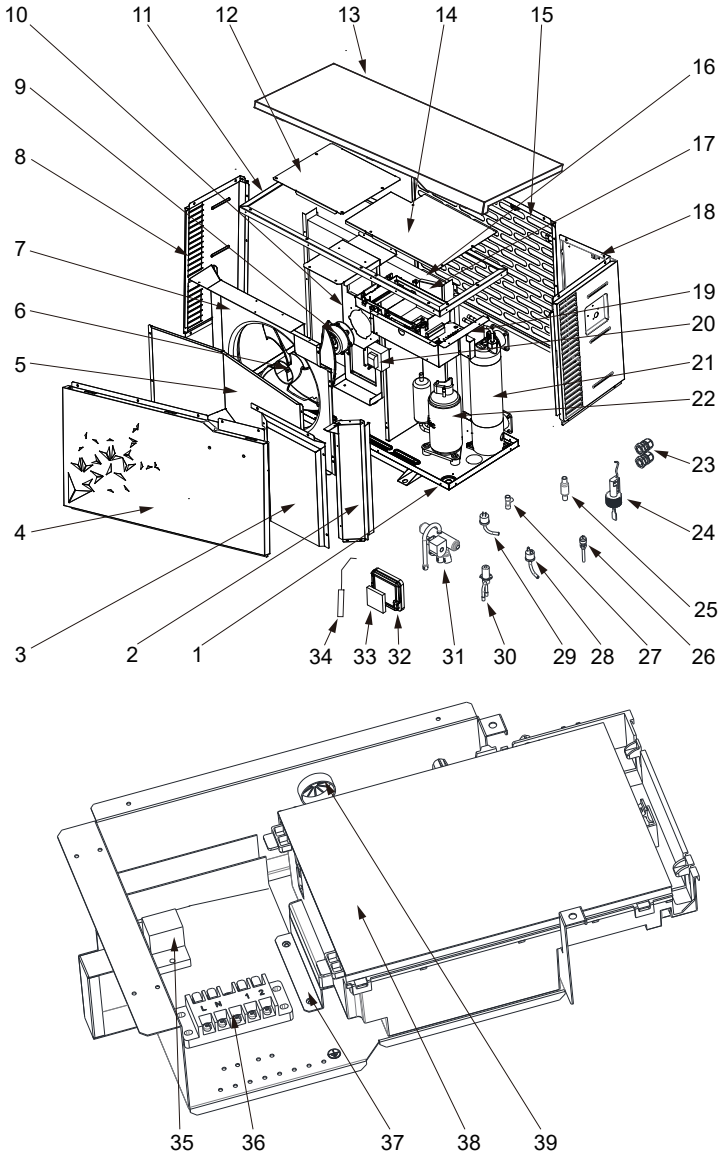

6. APPENDIX (continued)

Mark	Description	Ref.	HP5081DT3LV	HP5111DT3LV	HP5151DT3LV
34	Water outlet sensor 5k-410mm	HWX83000050	✓	✓	✓
	Water inlet sensor 5k-850mm	HWX83000052	✓	✓	✓
	Compressor discharge probe 50k-660mm	HWX83000026	✓	✓	✓
	Compressor aspiration sensor 5k-560mm	HWX83000044	✓	✓	n/a
	Compressor aspiration sensor 5k-760mm	HWX83000053	n/a	n/a	✓
	De-icing sensor 5k-680mm	HWX83000051	✓	✓	n/a
	De-icing sensor 5k-1040mm	HWX83000045	n/a	n/a	✓
35	Temperature sensor 5k-350mm	HWX83000049	✓	✓	✓
35	K2 relay	HWX20000360297	✓	✓	✓
36	Terminal block L-N-GND -5 connections 4mm ²	HWX40003901	✓	✓	✓
37	/	/	/	/	/
38	Printed circuit board Driver	HWX72200168SL08	✓	n/a	n/a
		HWX72200168SL11	n/a	✓	n/a
		HWX72200168SL15	n/a	n/a	✓
39	/	/	/	/	/

6. APPENDIX (continued)

6.4 Troubleshooting guide



Certain operations must be conducted by an authorised technician.

If a fault occurs, the following information appears on the screen:

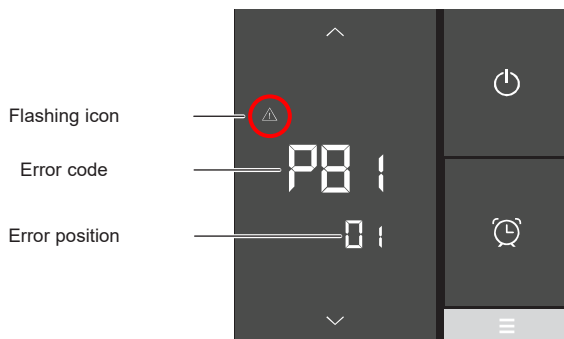

If there are several errors, press  or  to scroll through the list of error codes. See the table below.



Once the problem has been resolved, the error is cancelled automatically and the triangle disappears.

6. APPENDIX (continued)

Problem	Error codes	Description	Solution
Inlet water probe fault (IT)	P01	The sensor is open or short-circuiting	Check the connections on the extension connector or replace the sensor
Outlet water probe fault (OT)	P02		
Exterior temperature probe fault (AT)	P04		
De-icing sensor fault (CT)	P05		
Compressor aspiration sensor fault (SUT)	P07		
Compressor discharge sensor fault (ET)	P08		
High Pressure fault	E01	The sensor is open or short-circuiting	Check the connections on the extension connector or replace the sensor
			Check the water flow
			Check the water flow detector
			Check valve opening
			Check the by-pass
			Check the evaporator is not clogged
			Water temperature too hot
			Incondensable problem after maintenance, empty and evacuate the cooling circuit
Fluid load too high, remove fluid into a liquid bottle			
Low pressure fault	E02	The sensor is open or short-circuiting	Check the connections on the extension connector or replace the sensor
			Major refrigerant leak, use to detector to find the leak
			Air flow too low, check the ventilator rotation speed
			Check the evaporator is not clogged, clean its surface

6. APPENDIX (continued)

Problem	Error codes	Description	Solution
Flow detector defect	E03	The sensor is open or short-circuiting	Check the CN29/OVT connections on the board or replace the sensor
			Insufficient water, check operation of the filtration pump
			Check opening of the stop valves
			Check the by-pass setting
Inlet/Outlet temperature difference > 13°C	E05	Applicable in Cold mode only	Insufficient water, check operation of the filtration pump
			Check opening of the stop valves
			Check the by-pass setting
Anti-freezing protection	E07	Water outlet temperature < 4°C	Stop the heat pump and empty the condenser. Risk of freezing
Communication problem	E08	No communication between the electronic board and the user interface	Check the connections - see the wiring diagram
Level 1 anti-freezing protection	E19	2°C < Water Temperature < 4°C and Air Temperature < 0°C	Stop heat pump operation, empty the condenser to prevent freezing; by default the heat pump starts the filtration pump to prevent icing over
Level 2 anti-freezing protection	E29	Water Temperature < 2° and Air Temperature < 0°C	Stop heat pump operation, empty the condenser to prevent freezing; by default the heat pump starts the filtration pump to prevent icing over
Fan motor fault	F03 I	Motor blocked or connection fault	Check for smooth rotation; check the CN97/DCFAN connection; replace the motor
Fan motor fault	F05 I	Connection fault	Check the DCFAN/CN97 connection; replace the motor
Outside temperature too low	tP	Operating limit reached	Stop the heat pump
The heat pump will not start	- - - 0FF	Contact (5-6) Remote On/Off Open	Close contact (5-6) Remote On/Off (see wiring diagram)

6. APPENDIX (continued)

6.5 Warranty

WARRANTY CONDITIONS

All HAYWARD products are guaranteed to be free from manufacturing or material faults for a period of two years as from the date of purchase. Any claim made under the terms of the warranty must be accompanied by a dated proof of purchase. We therefore recommend that you keep your invoice.

The HAYWARD warranty is limited to the repair or replacement, at HAYWARD's discretion, of faulty products, provided they have been used under normal conditions, as described in their user guide, and that the product has not been modified in any way and has been used only with HAYWARD components and parts. Frost and chemical damage are not covered.

No other costs (transportation, labour, etc.) are covered by the warranty.

HAYWARD cannot be held liable for any direct or indirect damage caused by the incorrect installation, connection or operation of a product.

Please contact your retailer if you want to make a claim under the terms of the warranty and request the repair or replacement of an item. No equipment returned to our factory will be accepted without our prior written agreement.

Worn parts are not covered by the warranty.

Page left intentionally blank



S.Line Pro *Fi*

UNIDAD DE BOMBA DE CALOR PARA PISCINAS



Manual de Instalación e Instrucciones

ÍNDICE

1. PREFACIO	1
2. CARACTERÍSTICAS TÉCNICAS	4
2.1 Datos técnicos de la bomba de calor	4
2.2 Margen de funcionamiento	5
2.3 Dimensiones	6
3. INSTALACIÓN Y CONEXIÓN	7
3.1 Esquema eléctrico	7
3.2 Bomba de calor	7
3.3 Conexión hidráulica	8
3.4 Conexión eléctrica	9
3.5 Primer arranque	10
4. INTERFAZ DE USUARIO	12
4.1 Presentación general	12
4.2 Ajuste del caudal del agua	14
4.3 Ajuste del reloj	15
4.4 Ajuste de los Temporizadores de Encendido/Apagado	15
4.5 Ajuste de la función Temporizador en modo SILENCIO	17
4.6 Emparejamiento Bluetooth - Control a distancia	18
4.7 Elección del modo de funcionamiento	19
4.8 Ajuste y visualización del punto de referencia	20
4.9 Bloqueo y desbloqueo automático de la pantalla táctil	21
5. MANTENIMIENTO E INVIERNO	22
5.1 Mantenimiento	22
5.2 Invierno	22
6. ANEXOS	23
6.1 Esquemas eléctricos	23
6.2 Conexiones con prioridad al calentador de bomba monofásico	25
6.3 Despiece y piezas de recambio	26
6.4 Guía de solución de averías	30
6.5 Garantía	33

Leer atentamente y conservar para consultar con posterioridad.

Este documento debe suministrarse al propietario de la piscina y debe ser conservado por éste en un lugar seguro.

1. PREFACIO

Le agradecemos la compra de esta bomba de calor de piscina Hayward. La bomba de calor S.LINE PRO ha sido diseñada según normas estrictas de fabricación para satisfacer los más altos niveles de calidad requeridos.

Las bombas de calor S.LINE PRO le ofrecerán excepcionales prestaciones a todo lo largo de su temporada de baños, adaptando la potencia, el consumo eléctrico y el nivel sonoro a la necesidad de calentamiento de su piscina gracias a la lógica de control FULL INVERTER.



Lea atentamente las consignas de este manual antes de utilizar el aparato.

Las bombas de calor S.LINE PRO están exclusivamente destinadas a calentar el agua de la piscina, no utilizar este material para otros fines.

El presente manual incluye todas las informaciones necesarias referentes a la instalación, la eliminación de los disfuncionamientos y el mantenimiento.

Lea atentamente este manual antes de abrir la unidad o de realizar operaciones de mantenimiento en la misma. En ningún caso, el fabricante del producto será responsable en caso de lesiones de un usuario o de daño de la unidad debido a eventuales errores de instalación, de eliminación de disfuncionamientos o de un mantenimiento inadecuado. Es primordial seguir en todo momento las instrucciones especificadas en este manual.

El no respeto de cualquier recomendación anula la garantía.

1. PREFACIO (continuación)



Consignas de seguridad



Este aparato contiene R32.

Nunca utilizar otro refrigerante que no sea el R32. Cualquier otro cuerpo gaseoso mezclado con el R32 corre el riesgo de provocar presiones anormalmente elevadas que pueden ocasionar una avería o una ruptura de tubos y lesionar personas.

Durante las reparaciones u operaciones de mantenimiento, utilice tubos de cobre que cumplan con la Norma EN 12375-1 (mayo de 2020) y la Directiva Europea de Equipos a Presión 97/23 / EC.

Como la bomba de calor está a presión, nunca perforar los tubos ni intentar hacer una soldadura. Hay riesgo de explosión.

Nunca exponer el aparato a llamas, chispas ni otras fuentes de encendido. Podría explosionar y ocasionar lesiones graves, incluso mortales.



La bomba de calor está exclusivamente prevista para instalar al exterior de edificios.

- En caso de almacenamiento, la bomba de calor se debe almacenar en una habitación bien ventilada y con una superficie de más de A_{\min} (m²) dada por la siguiente fórmula: $A_{\min} = (M / (2,5 \times 0,22759 \times h_0))^2$
M es la carga de refrigerante en el aparato en kg y h₀ es la altura de almacenamiento. Para almacenar sobre el suelo h₀ = 0,6 m.
- La unidad debe ser instalada por un personal calificado.
- No instalar la bomba de calor sobre un soporte que pueda amplificar las vibraciones de la unidad.
- Verificar que el soporte previsto para la unidad está correctamente dimensionado para el peso del aparato.
- No instalar la bomba de calor en un lugar que pueda amplificar su nivel sonoro o en un lugar donde el ruido de la unidad pueda molestar a los vecinos.
- Todas las conexiones eléctricas deben ser efectuadas por un electricista profesional calificado y según las normas vigentes en el país de instalación, ver § 3.4.
- Cortar la aplicación principal y el seccionador antes de cualquier trabajo eléctrico. Todo olvido puede causar electrocución.
- Antes de la instalación, verificar que el cable de tierra no está cortado ni desconectado.

1. PREFACIO (continuación)

- Conectar y apretar convenientemente el cable de alimentación eléctrica. Si la conexión es incorrecta, las partes eléctricas se pueden dañar.
- La exposición de la bomba de calor al agua o a un medio húmedo puede provocar una electrocución. Esté muy vigilante.
- Si detecta cualquier defecto o situación anormal, no instale la bomba de calor y contacte inmediatamente con su revendedor.
- El mantenimiento y las diferentes operaciones se deben realizar a la frecuencia y en los momentos recomendados, como se especifica en el presente manual.
- Las reparaciones deben ser efectuadas por un personal calificado.
- Solo utilice piezas de recambio originales.
- Nunca utilizar otro procedimiento de limpieza que no sea el recomendado en este manual.

Informaciones importantes referentes al refrigerante utilizado.

Este producto contiene gases fluorados de efecto invernadero enmarcados por el protocolo de Kioto. No libere estos gases a la atmósfera.

Tipo de refrigerante: R32

Valor GWP(1): 675, valor basado en el 4to informe del IPCC.

La cantidad de refrigerante basada en el reglamento n.º 517/2014 (F-Gas) se indica en la placa de características de la unidad.

En función de la legislación europea o local, se pueden exigir inspecciones periódicas de fuga del refrigerante. Contacte con su distribuidor local para más informaciones.

(1) Potencial de calentamiento global

2. CARACTERÍSTICAS TÉCNICAS

2.1 Datos técnicos de la bomba de calor

Modelos	S.LINE PRO	HP5081DT3LV	HP5111DT3LV	HP5151DT3LV
Tensión de alimentación	V	220 V-240 V ~ / monofásica / 50 Hz		
Refrigerante	/	R32		
Carga	kg	0,45	0,50	0,65
Masa en tCO ₂ eq	/	0,30	0,34	0,44
Frecuencia de control de fuga	/	Ninguna exigencia, pero se recomienda una vez al año		
Capacidad de calentamiento Mín--Máx ^(a)	kW	2,83 -- 8,16	1,95 -- 10,90	5,27 -- 15,66
Potencia eléctrica absorbida Mín--Máx ^(a)	kW	0,212 -- 1,19	0,150 -- 1,92	0,457 -- 2,80
Corriente nominal de servicio Mín--Máx ^(a)	A	1,41 -- 5,20	1,05 -- 8,49	2,04 -- 12,28
COP Máx--Mín ^(a)	/	13,30 -- 6,81	12,92 -- 5,67	11,53 -- 5,59
Capacidad de calentamiento Mín--Máx ^(b)	kW	1,77 -- 5,91	1,86 -- 8,40	3,81 -- 11,67
Potencia eléctrica absorbida Mín--Máx ^(b)	kW	0,31 -- 1,28	0,30 -- 1,83	0,588 -- 2,71
COP Máx--Mín ^(b)	/	5,70 -- 4,62	6,20 -- 4,59	6,48 -- 4,31
Corriente máxima de servicio (CMS)	A	6,50	10,30	14
Calibre del fusible	gG	10	12	16
Disyuntor curva C	C	10	12	16
Intensidad por arranque	A	< CMS		
Conexión hidráulica	mm	50 mm		
Caudal nominal de agua ^(a)	m ³ /h	3,50	4,60	6,70
Pérdida de carga máxima en el agua	kPa	8	5	10
Compresor	/	DC Inverter MITSUBISHI ELECTRIC		DC Inverter Mitsubishi
Tipo	/	Rotativo doble		Rotativo doble
Cantidad	/	1		
Resistencia de enrollado a 20°C	Ohmio	1,91 +/- 5%		0,95 +/- 5%
Ventilador	/	Axial		
Cantidad	/	1		
Diámetro	mm	405		500
Cantidad de aletas	/	3		
Motor	/	Inversor CD		
Cantidad	/	1		
Velocidad de rotación	rpm	500 -- 800	500 -- 900	500 -- 750
Velocidad modo silencio	rpm	500	500	500
Nivel de presión acústica a 1 m	dB(A)	45,1	48,6	54,1
Nivel de presión acústica a 10 m	dB(A)	27,9	31,6	36,9
Dimensiones netas de la unidad (longitud-ancho-altura)	mm	1011 / 430 / 622		1025 / 480 / 768
Masa	kg	61	61	87



(a) Aire seco 27°C - Humedad relativa 78% - Temperatura de entrada del agua 26°C.

(b) Aire seco 15°C - Humedad relativa 71% - Temperatura de entrada del agua 26°C.

2. CARACTERÍSTICAS TÉCNICAS (continuación)

2.2 Margen de funcionamiento

Utilizar la bomba de calor dentro de los siguientes márgenes de temperatura y de humedad para garantizar un funcionamiento seguro y eficaz.

	Modo calentamiento 	Modo enfriamiento 
Temperatura exterior	-7°C – +35°C	+7°C – +43°C
Temperatura del agua	+12°C – +32°C	+8°C – +40°C
Humedad relativa	< 80%	< 80%
Margen de reglaje del punto de referencia	+15°C – +32°C	+8°C – +32°C



Si la temperatura o la humedad no corresponden a estas condiciones, los dispositivos de seguridad pueden activarse y la bomba de calor puede no funcionar.



La temperatura máxima de calentamiento está limitada a 32°C para evitar el deterioro de los revestimientos. Hayward no se hace responsable en el caso de un uso por encima de +32°C.

2. CARACTERÍSTICAS TÉCNICAS (continuación)

2.3 Dimensiones

Modelos:

HP5081DT3LV / HP5111DT3LV / HP5151DT3LV

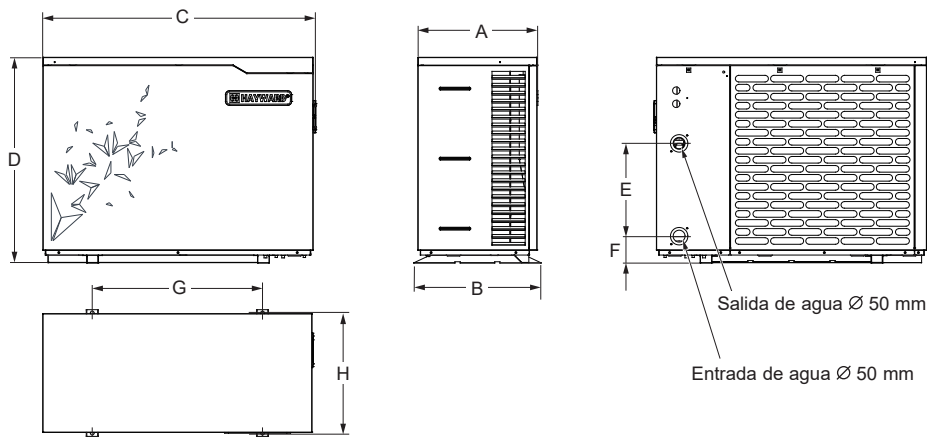

Unidad : mm

Referencia \ Modelo	HP5081DT3LV / HP5111DT3LV	HP5151DT3LV
A	393	453
B	430	480
C	1011	1030
D	621,5	776
E	350	350
F	97,5	102
G	625	645
H	406	456

3. INSTALACIÓN Y CONEXIÓN

3.1 Esquema eléctrico

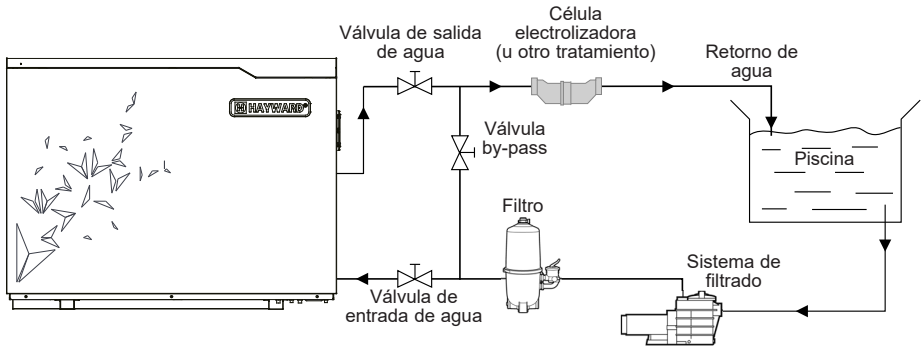

Nota: La bomba de calor se suministra sin ningún equipo de tratamiento o filtración. Los elementos que aparecen en el esquema son las piezas que deberá proporcionar el instalador.

3.2 Bomba de calor



Colocar la bomba de calor en el exterior y fuera de cualquier sala técnica cerrado.

Colocar en una zona resguarda, las distancias mínimas que a continuación se prescriben deben ser respetadas a fin de evitar cualquier riesgo de recirculación del aire y de una degradación del rendimiento global de la bomba de calor.

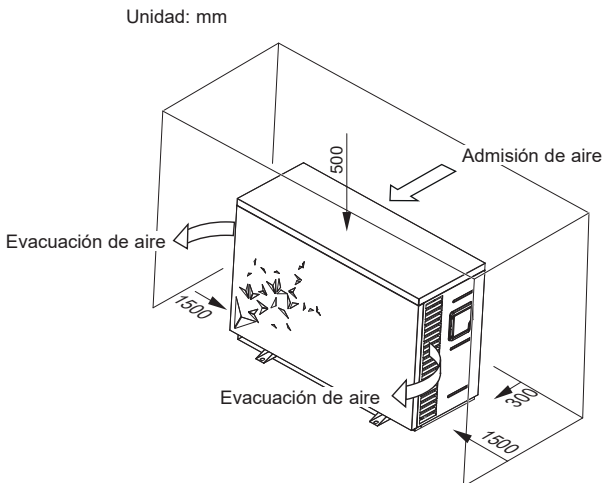

3. INSTALACIÓN Y CONEXIÓN (continuación)



Preferiblemente instale la bomba de calor sobre una superficie de hormigón aislada o una silla de fijación prevista a tal fin y monte la bomba de calor sobre los silentblocs suministrados (los tornillos y arandelas no se suministran).

Distancia máxima de instalación entre la bomba de calor y la piscina 15 metros.

Longitud total de ida-vuelta de las canalizaciones hidráulicas 30 metros.

Aislar las canalizaciones hidráulicas de superficie y enterradas.

La bomba de calor debe instalarse a una distancia mínima de la piscina en cumplimiento de la NF C 15-100 (es decir a 3,5 m de la piscina para Francia) o según las normas de instalación vigentes en el resto de países.

No instalar la bomba de calor cerca de una fuente de calor.

En caso de instalación en regiones nevosas, se recomienda poner la máquina a resguardo para evitar una acumulación de nieve sobre el evaporador.

3.3 Conexión hidráulica

La bomba de calor se suministra con dos conexiones de unión de 50 mm de diámetro. Utilice un tubo de PVC para la canalización hidráulica \varnothing 50 mm. Conecte la entrada de agua de la bomba de calor al conducto proveniente del grupo de filtración, tras esto conecte la salida de agua de la bomba de calor al conducto de agua que va a la piscina (cf esquema de abajo).

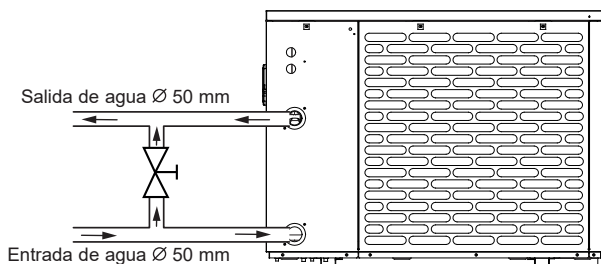

Instale una válvula "by-pass" entre la entrada y la salida de la bomba de calor.



Si se utiliza un distribuidor automático o un electrolizador, se debe instalar obligatoriamente después de la bomba de calor con el fin de proteger el condensador de titanio de una concentración demasiado grande de producto químico.



Se ruega instale la válvula by-pass y las conexiones de unión suministradas al nivel de la entrada y la salida de agua de la unidad, con el fin de simplificar la purga durante el periodo invernal y de facilitar el acceso o el desmontaje para el mantenimiento.

3. INSTALACIÓN Y CONEXIÓN (continuación)

3.4 Conexión eléctrica



La instalación eléctrica y el cableado de este equipo debe cumplir con la normativa de instalación local en vigor.

F	NF C15-100	GB	BS7671:1992
D	DIN VDE 0100-702	EW	EVHS-HD 384-7-702
A	ÖVE 8001-4-702	H	MSZ 2364-702/1994/MSZ 10-553 1/1990
E	UNE 20460-7-702 1993, RECBT ITC-BT-31 2002	M	MSA HD 384-7-702.S2
IRL	Wiring Rules + IS HD 384-7-702	PL	PN-IEC 60364-7-702:1999
I	CEI 64-8/7	CZ	CSN 33 2000 7-702
LUX	384-7.702 S2	SK	STN 33 2000-7-702
NL	NEN 1010-7-702	SLO	SIST HD 384-7-702.S2
P	RSIUEE	TR	TS IEC 60364-7-702



Compruebe que la alimentación eléctrica disponible y la frecuencia de la red corresponden con la corriente de funcionamiento requerida, teniendo en consideración el emplazamiento específico del aparato y la corriente necesaria para alimentar cualquier otro aparato que esté conectado al mismo circuito.

HP5081DT3LV / HP5111DT3LV / HP5151DT3LV
230V ~ +/- 10 % 50 Hz 1 Fase

Observe el esquema de cableado correspondiente en el anexo.
Hay tres conexiones destinadas a la alimentación eléctrica y dos para el control del sistema de filtrado (servomecanismo).

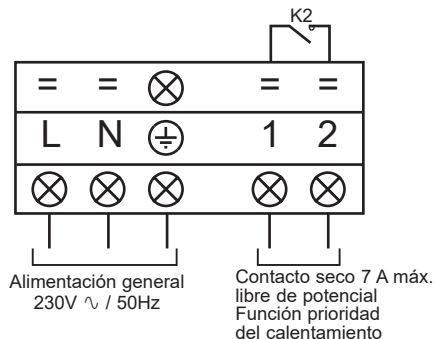

3. INSTALACIÓN Y CONEXIÓN (continuación)



La línea de alimentación eléctrica debe estar dotada, de manera apropiada, de un dispositivo de protección del tipo fusible de acompañamiento del motor (gG) o disyuntor curva C, así como de un disyuntor diferencial 30mA (ver tabla a continuación).

Modelos		HP5081DT3LV	HP5111DT3LV	HP5151DT3LV
Alimentación eléctrica	V/Ph/Hz	230V~ 50Hz	230V~ 50Hz	230V~ 50Hz
Calibre de fusible tipo gG	A	10 gG	12 gG	16 gG
Disyuntor curva C	A	10 C	12 C	16 C
Sección de cable	mm ²	3G 2,5	3G 2,5	3G 2,5



Use un cable de alimentación de tipo RO 2 V / R 2 V o equivalente.



Las secciones de cable indicadas se corresponden a una longitud máxima de 25 m. Sin embargo, deben comprobarse y adaptarse en función de las condiciones de instalación.



Tenga siempre cuidado de detener la alimentación principal antes de abrir la caja de control eléctrico.

3.5 Primer arranque

Procedimiento de arranque - una vez que se ha terminado la instalación, siga y respete las siguientes etapas:

- 1) Gire los ventiladores con la mano para comprobar que pueden girar libremente y que la hélice está correctamente fijada al árbol del motor.
- 2) Asegúrese de que la unidad está conectada correctamente a la alimentación principal (ver el esquema de cableado en el anexo).
- 3) Active el sistema de filtrado.
- 4) Verifique que todas las válvulas de agua están abiertas y que el agua circula hacia la unidad antes de pasar al modo de calentamiento o enfriamiento.
- 5) Verifique que la acometida de purga de condensados está fijada correctamente y no presenta ninguna obstrucción.
- 6) Activar la alimentación eléctrica destinada a la unidad, después presione el botón de Marcha/Parada  sobre el panel de control.

3. INSTALACIÓN Y CONEXIÓN (continuación)

- 7) Cerciórese de que no se visualicen los símbolos de alarma o de bloqueo. Dado el caso, ver la guía de reparación (ver § 6.4).
- 8) Fije el caudal de agua con la ayuda de la válvula by-pass (ver § 2.1 y 4.2), tal y como se prevee respectivamente para cada modelo de manera que obtenga una diferencia de temperatura Entrada/ Salida de 2°C.
- 9) Tras estar funcionando unos cuantos minutos, verifique que el aire sale de la unidad y se enfría (entre 5°C y 10°C).
- 10) Estando la unidad en servicio, desactive el sistema de filtrado. La unidad debe pararse automáticamente y mostrar el código de error E03.
- 11) Haga funcionar la unidad y la bomba de la piscina durante 24 horas seguidas, hasta que se alcance la temperatura del agua deseada. Cuando la temperatura de entrada del agua alcance el valor de referencia, la unidad se para. Se pone en funcionamiento de nuevo automáticamente (siempre que la bomba de la piscina esté en servicio) si la temperatura desciende menos de 0,5°C por debajo de la temperatura de referencia.

Controlador del caudal - La unidad está dotada de un controlador de caudal que activa la bomba de calor mientras el sistema de filtrado de la piscina está en servicio y la desactiva cuando el sistema de filtrado está fuera de servicio. Por falta de agua, el código de alarma E03 aparece en el regulador (Ver § 6.4).

Temporización - la unidad integra una temporización de 3 minutos, que tiene por objeto proteger los componentes del circuito de control, eliminar cualquier inestabilidad en el arranque y cualquier interferencia del contactor. Por medio de esta temporización, la unidad arranca de nuevo automáticamente unos 3 minutos después de que se produzca un corte del circuito de control. Incluso un corte de corriente de corta duración activa la temporización de arranque.

4. INTERFAZ DE USUARIO

4.1 Presentación general

La bomba de calor está equipada con un panel de control digital con pantalla táctil, que va conectado eléctricamente y que está programado previamente de fábrica en modo calentamiento.

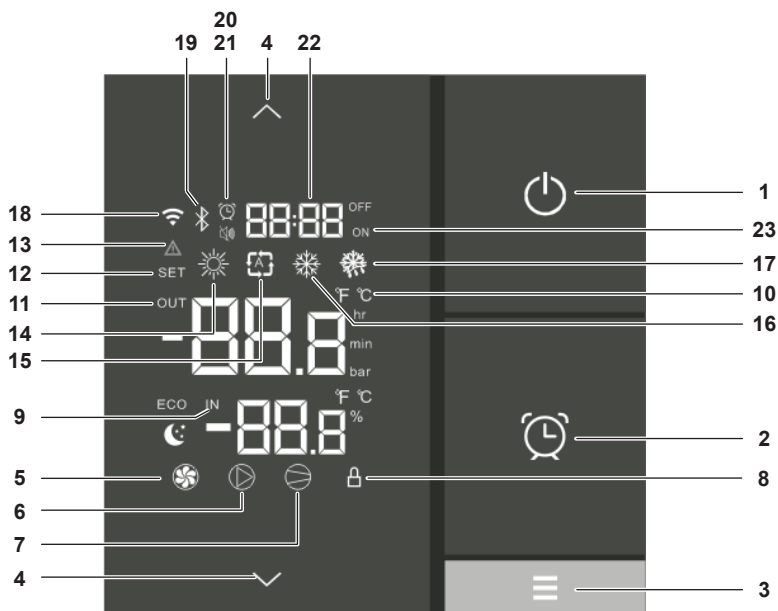

Leyenda

1		Encendido/Apagado/Cancelación
2		Ajuste de la Hora y Temporizadores
3		Elección del modo de funcionamiento
4		Desplazamiento hacia Arriba/Abajo, +°C/-°C
5		Ventilador ON
6		Contacto seco OUT2 ON
7		Compresor ON
8		Pantalla bloqueada
9		Entrada de agua
10		Celsius/Fahrenheit
11		Salida de agua
12		Ajuste de los parámetros avanzados

13		Fallo del sistema
14		Modo calentamiento
15		Modo automático
16		Modo enfriamiento
17		Modo deshielo
18		N/A
19		Conexión Bluetooth
20		Temporizador programado
21		Testigo del modo Silencio/Temporizador
22		Hora/Hora de los temporizadores
23		Temporizadores programados de Apagado y Encendido

4. INTERFAZ DE USUARIO (continuación)

Modo OFF/APAGADO

Cuando la bomba de calor está en modo espera (Modo OFF) aparece la inscripción OFF en la pantalla del regulador y la pantalla pasa al modo ahorro de energía al cabo de un minuto.

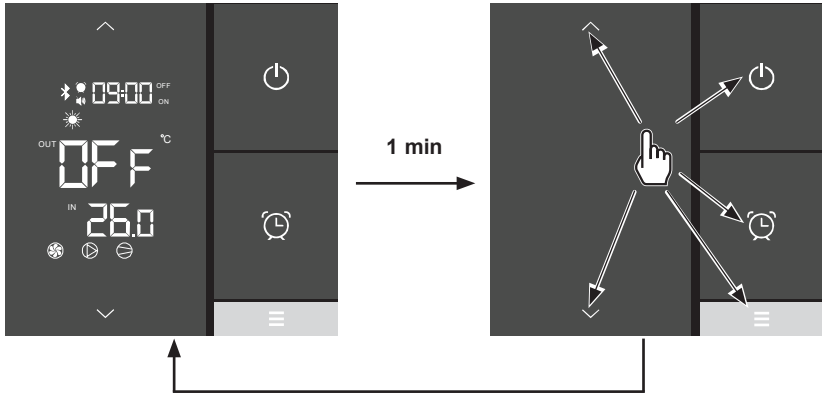

Para volver a la visualización completa, pulse cualquier botón.

Modo ON

Cuando la bomba de calor está en funcionamiento o en modo regulación (Modo ON), las temperaturas de entrada y de salida del agua aparecen en la pantalla del regulador y la pantalla pasa al modo ahorro de energía al cabo de un minuto.

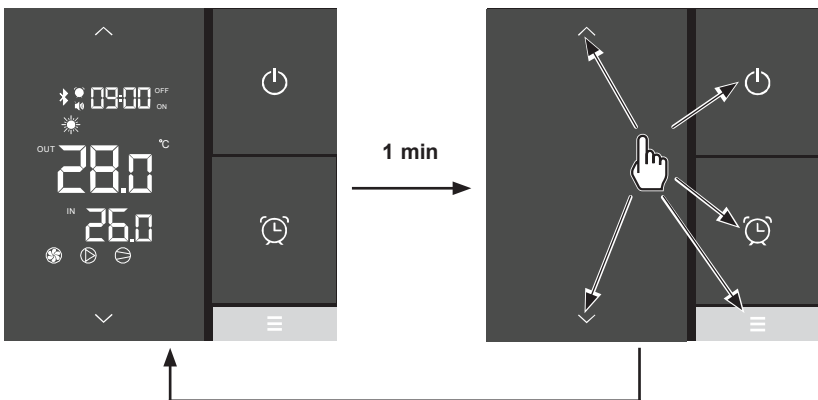

Para volver a la visualización completa, pulse cualquier botón.

4. INTERFAZ DE USUARIO (continuación)

4.2 Ajuste del caudal del agua

Con las válvulas de entrada y salida de agua abiertas, ajustar la válvula «by-pass» hasta obtener una diferencia de 2 °C entre la temperatura de entrada y de salida del agua (véase el esquema eléctrico, párrafo 3.1).

Puede comprobar el ajuste visualizando las temperaturas de entrada/salida directamente en el panel de control siguiendo el procedimiento siguiente.



Después, ajustar el By-pass para obtener una diferencia de 2 °C entre la entrada y la salida.

Pulsar  para salir del menú.

- La apertura de la válvula «by-pass» genera un caudal menos importante en el intercambiador de la bomba de calor, lo que provoca un aumento de la diferencia de la temperatura de entrada/salida.
- El cierre de la válvula «by-pass» genera un caudal más importante en el intercambiador de la bomba de calor, lo que provoca un descenso de la diferencia de la temperatura de entrada/salida.

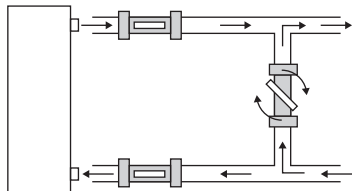

Es posible comprobar el ajuste visualizando las temperaturas de entrada/salida (1-2) directamente en la aplicación «EyesPool Inverter Connect» (ver párrafo 4.6).











4. INTERFAZ DE USUARIO (continuación)

4.3 Ajuste del reloj

Al final de los ajustes, pulsar  para confirmar.

Los ajustes se guardarán automáticamente al cabo de 5 segundos de inactividad.













- Pulsar , la hora parpadea.
- Pulsar , las horas parpadean. Ajustar las horas con los botones  y .
- Pulsar , después ajustar los minutos con los botones  y .
- Confirmar pulsando .

4.4 Ajuste de los Temporizadores de Encendido/Apagado

El ajuste de esta función es necesario si desea que la bomba de calor funcione durante un periodo más corto que el definido por el reloj de filtración. De ese modo, podrá programar un inicio diferido y una parada anticipada o simplemente prohibir un tramo horario de funcionamiento (por ejemplo de noche).

Tiene la posibilidad de programar un Temporizador de Inicio (ON) y un Temporizador de Apagado (OFF).

Programación del Temporizador - Inicio (ON)

- Pulsar  durante 2 segundos, hasta que el icono  parpadee.
- Pulsar ,  parpadea ().
- Pulsar , para ajustar las horas con los botones  y .
- Pulsar , para ajustar los minutos con los botones  y .
- Confirmar pulsando  y después  para volver a la pantalla principal.















Los ajustes se guardarán automáticamente al cabo de 20 s de inactividad.

El ajuste de los minutos se hace por tramos de 10 minutos.

La indicación ON debajo de la hora en la pantalla principal indica que el Temporizador de Inicio (ON) está programado.

4. INTERFAZ DE USUARIO (continuación)

Programación del Temporizador - Apagado (OFF)







- Pulsar  durante 2 segundos, hasta que el icono  parpadee.
- Pulsar  ,  parpadea (**ON**).
- Pulsar  ,  parpadea (**OFF**).
- Pulsar  para ajustar las horas con los botones  y .
- Pulsar  para ajustar los minutos con los botones  y .
- Confirmar pulsando  y después  para volver a la pantalla principal.

Los ajustes se guardarán automáticamente al cabo de 20 s de inactividad.

El ajuste de los minutos se hace por tramos de 10 minutos.

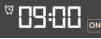



La indicación OFF arriba de la hora en la pantalla principal indica que el Temporizador de Apagado (OFF) está programado.

Consulta de los Temporizadores





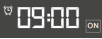

- Pulsar  durante 2 segundos, hasta que el icono  parpadee.
- Pulsar  , la hora de Inicio  parpadea.
- Pulsar  , la hora de apagado  parpadea.
- Pulsar  para volver a la pantalla principal.

El icono  aparece en la pantalla principal cuando haya programado un temporizador de Inicio y/o un temporizador de Apagado.

Eliminación de los Temporizadores de Inicio (ON) y de Apagado (OFF)











- Pulsar  durante 2 segundos, hasta que el icono  parpadee.
- Pulsar 2 veces  , las horas de inicio parpadean .
- Pulsar  para eliminar el Temporizador de inicio .

Al final de la etapa 3, pulsar  para volver a la pantalla principal o pasar a la etapa 4 para continuar.

- Pulsar  para acceder al horario de apagado .
- Pulsar  , las horas de apagado parpadean .
- Pulsar  para eliminar el Temporizador de apagado .
- Pulsar  para volver a la pantalla principal.

4. INTERFAZ DE USUARIO (continuación)

















Eliminación del Temporizador de Apagado (OFF)

- Pulsar  durante 2 segundos, hasta que el icono  parpadee.
- Pulsar 2 veces , las horas de inicio parpadean .
- Pulsar  para acceder al horario de apagado .
- Pulsar  las horas de apagado parpadean .
- Pulsar  para eliminar el Temporizador de apagado .
- Pulsar  para volver a la pantalla principal.









4.5 Ajuste de la función Temporizador en modo SILENCIO

El modo SILENCIO permite usar la bomba de calor en modo ahorro y de forma muy silenciosa cuando las necesidades de calentamiento son bajas (para mantener la temperatura de la piscina o en caso de necesitar un funcionamiento ultrasilencioso).

Programación del Temporizador en modo SILENCIO

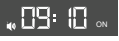
- Pulsar  durante 2 segundos, hasta que el icono  parpadee.
- Pulsar , el icono  parpadea.
- Pulsar ,  parpadea.
- Pulsar  para ajustar la hora de inicio con los botones  y .
- Pulsar , después ,  parpadea.
- Pulsar  para ajustar la hora de apagado con los botones  y .
- Confirmar pulsando  y después  para volver a la pantalla principal.

Eliminación del Temporizador en modo SILENCIO







- Pulsar  durante 2 segundos, hasta que el icono  parpadee.
- Pulsar , el icono  parpadea.
- Pulsar , la hora de Inicio  parpadea.
- Pulsar , solo las horas parpadean.
- Pulsar ,  parpadea.
- Pulsar  para volver a la pantalla principal.

La eliminación del Temporizador de Encendido genera sistemáticamente la eliminación del Temporizador de Apagado.

El tramo de ajuste es «de hora en hora».

4. INTERFAZ DE USUARIO (continuación)

Programación del Temporizador de Modo SILENCIO

- Pulsar  durante 2 segundos, hasta que el icono  parpadee.
- Pulsar , el icono  parpadea.
- Pulsar  para visualizar la hora de inicio.
- Pulsar  para visualizar la hora de apagado.
- Pulsar  para volver a la pantalla principal.



Cuando aparece el icono  en la pantalla principal, es que hay un Temporizador de Inicio o un Temporizador de Apagado programado para el modo SILENCIO.

4.6 Emparejamiento Bluetooth - Control a distancia

La bomba de calor está equipada con la función Bluetooth.

Con la aplicación «*EyesPool Inverter Connect*», podrá utilizar su teléfono inteligente de mando a distancia para controlar la bomba de calor dentro de un límite de 10 m en campo abierto.

Para disponer de esta función  **Bluetooth**:

- ▶ Descargar la aplicación gratuita «*EyesPool Inverter Connect*» en 
o  .
- ▶ Crear una cuenta en la aplicación.
- ▶ Seguir las instrucciones del vídeo (enlace a continuación) para emparejar el teléfono inteligente con la bomba de calor:
<https://www.hayward.fr/article/tutoriels-hayward/s-line-pro-bluetooth-appairage>



4. INTERFAZ DE USUARIO (continuación)

4.7 Elección del modo de funcionamiento

Calentamiento - Automático - Enfriamiento



Si la bomba de calor estuviera ajustada en modo Solo calor o Solo frío por el instalador, el cambio de modo ya no estaría disponible.

Pulsar el botón  para cambiar de modo: Calentamiento - Automático - Enfriamiento.

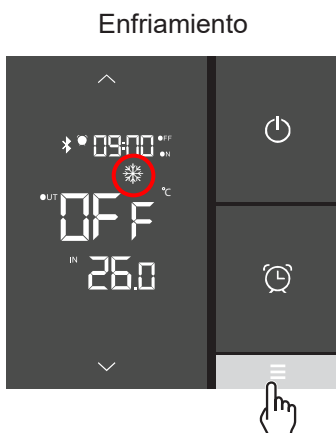
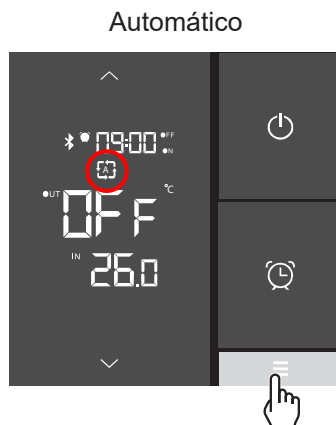
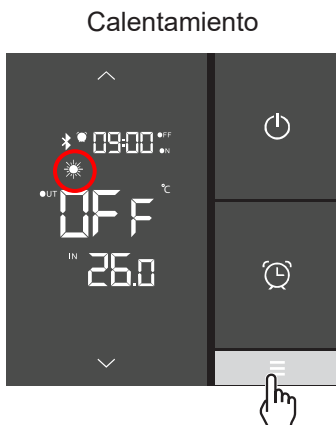





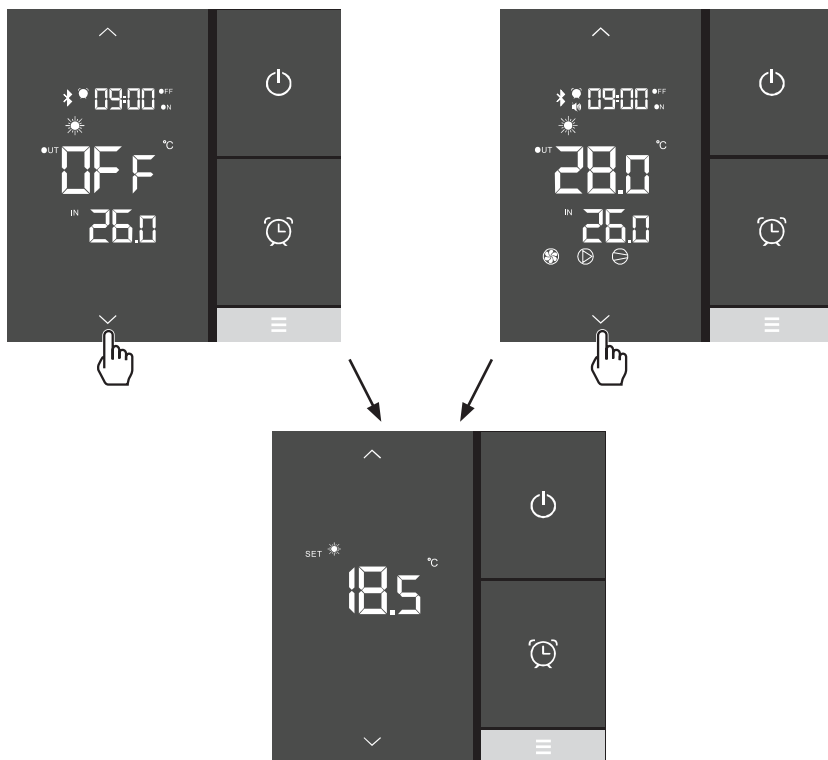

4. INTERFAZ DE USUARIO (continuación)

4.8 Ajuste y visualización del punto de referencia

Temperatura de agua deseada

El ajuste del punto de referencia se realiza tanto en modo ON como en modo ON con una precisión de 0,5 °C.



- Pulsar  o  para que parpadee el punto de referencia.
- Pulsar  o  para definir el punto de referencia deseado.
- Pulsar  para confirmar o  para cancelar.

El ajuste se guardará automáticamente al cabo de 5 segundos de inactividad.







Se recomienda no superar nunca la temperatura de 30 °C para evitar la alteración de los revestimientos.

4. INTERFAZ DE USUARIO (continuación)

4.9 Bloqueo y desbloqueo automático de la pantalla táctil

El bloqueo y el desbloqueo de la pantalla puede hacerse tanto en modo ON como en modo OFF.

- Pulsar  durante 5 segundos hasta que aparezca el icono .
- Para desbloquear, pulsar  hasta que desaparezca el icono .

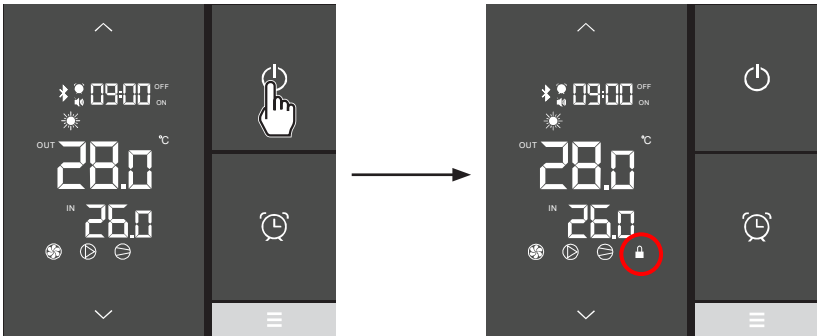

5. MANTENIMIENTO E INVIERNO

5.1 Mantenimiento

Estas operaciones de mantenimiento deben realizarse 1 vez al año con el fin de garantizar la longevidad y el buen funcionamiento de la bomba de calor.

- Limpie el evaporador con un cepillo flexible o de un chorro de aire o agua (**Atención no utilizar jamás un limpiador de alta presión**).
- Verifique el buen flujo de los condensados.
- Compruebe la fijación de las conexiones hidráulicas y eléctricas
- Compruebe la estanqueidad hidráulica del condensador.
- **Un profesional autorizado** deberá comprobar la estanqueidad del circuito frigorífico con un detector de fugas.



Antes de realizar cualquier operación de mantenimiento, la bomba de calor debe estar desconectada de cualquier fuente de corriente eléctrica. Las operaciones de mantenimiento deben ser realizadas únicamente por personal cualificado y capacitado para manipular fluidos frigorígenos.

5.2 Invierno

- Poner la bomba de calor en Modo "OFF".
- Cortar la alimentación de la bomba de calor.
- Vaciar el condensador a través del desagüe para evitar cualquier riesgo de degradación. (riesgo importante de congelación).
- Cerrar la válvula "by-pass" y desatornillar las conexiones de unión entrada/salida.
- Expulse toda el agua estancada residual del condensador ayudándose con una pistola de aire.
- Obture la entrada y la salida de agua a la bomba de calor para evitar la intrusión de cuerpos extraños.
- Cubrir la bomba de calor con una funda de protección para el invierno.



Cualquier daño ocasionado por un mal mantenimiento invernal conlleva la anulación de la garantía.

6. ANEXOS

6.1 Esquemas eléctricos

HP5081DT3LVM / HP5111DT3LV

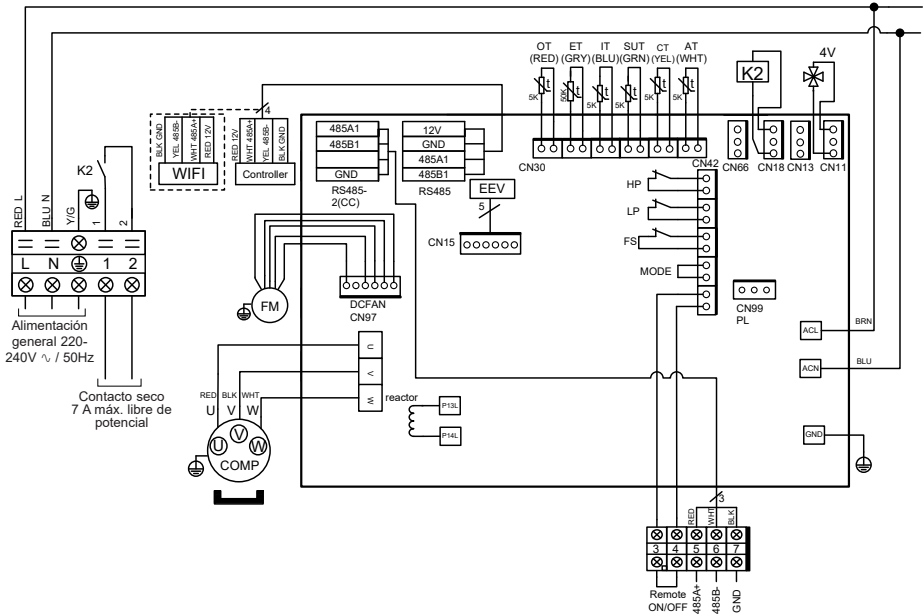

LEYENDA

- | | |
|---|--|
| AT : SONDA DE TEMPERATURA DE AIRE | LP : PRESOSTATO BAJA PRESIÓN |
| COMP : COMPRESOR | OT : ONDA DE TEMPERATURA DE ENTRADA DE AGUA |
| CT : SONDA DE TEMPERATURA EVAPORADOR | SUT : SONDA DE TEMPERATURA DE ASPIRACIÓN |
| EEV : DESCOMPRESOR ELECTRÓNICO | 4V : VÁLVULA 4 VÍAS |
| FM : MOTOR VENTILADOR | K2 : CONTACTO SECO LIBRE DE 7 A MÁX. |
| FS : DETECTOR DE PRESENCIA DE AGUA | ET : SONDA DE TEMPERATURA DE DESCARGA |
| HP : PRESOSTATO ALTA PRESIÓN | ⋮ : OPCIÓN |
| IT : SONDA DE TEMPERATURA DE ENTRADA DE AGUA | |

6. ANEXOS (continuación)

HP5151DT3LV

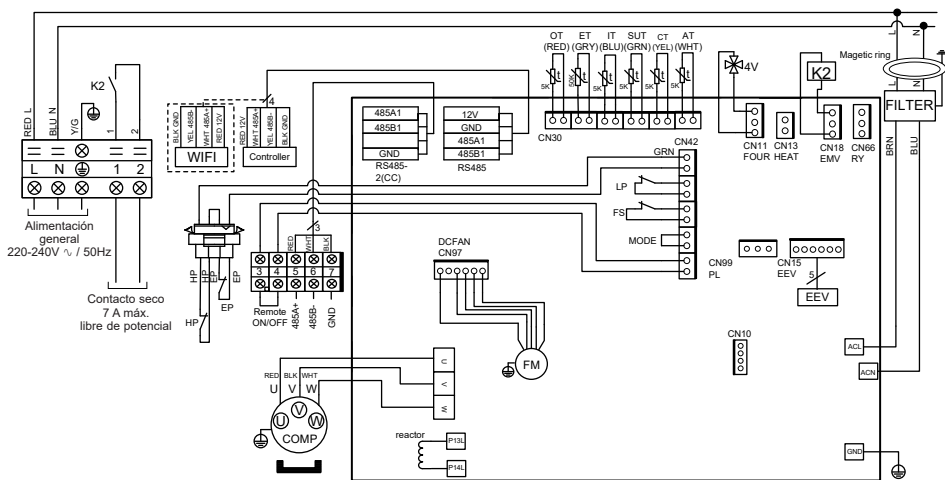

LEYENDA

- | | |
|---|---|
| AT : Sonda de temperatura de aire | LP : Presostato baja presión |
| COMP : Compresor | OT : Sonda de temperatura de entrada de agua |
| CT : Sonda de temperatura evaporador | SUT : Sonda de temperatura de aspiración |
| EEV : Descompresor electrónico | 4V : Válvula 4 vías |
| FM : Motor ventilador | K2 : Contacto seco libre de 7 A máx. |
| FS : Detector de presencia de agua | ET : Sonda de temperatura de descarga |
| HP : Presostato alta presión | OPCIÓN : Opción |
| IT : Sonda de temperatura de entrada de agua | |

6. ANEXOS (continuación)

6.2 Conexiones con prioridad al calentador de bomba monofásico

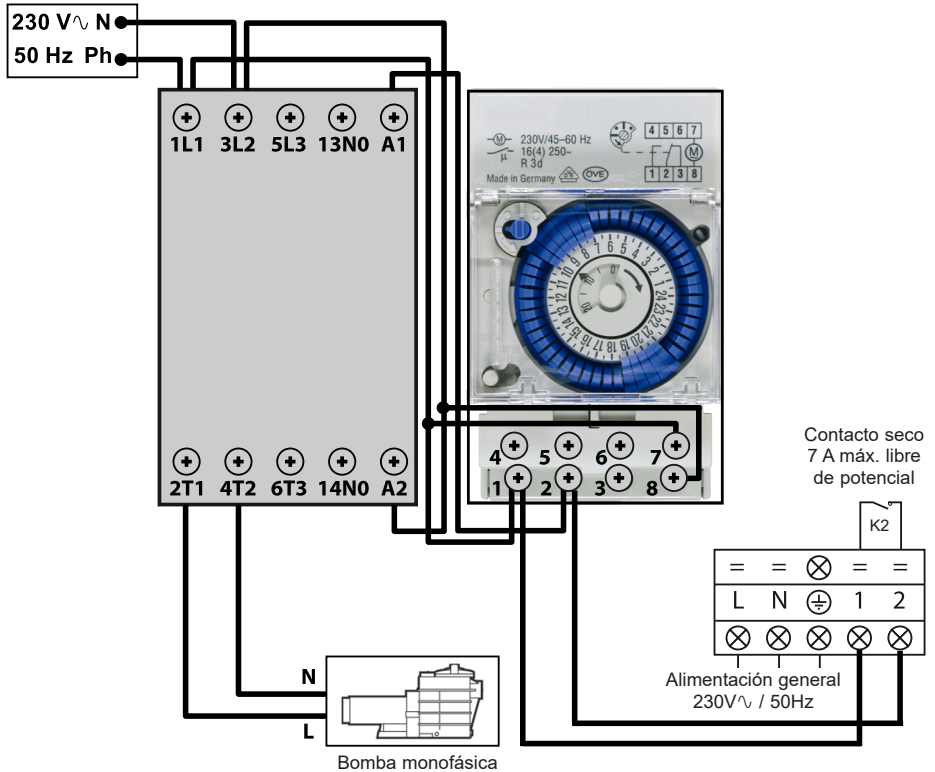

Los bornes 1 y 2 suministran un contacto seco (libre de potencial), sin polaridad de 230 V ~ / 50 Hz.

Conecte los cables a los bornes 1 y 2 respetando el esquema de cableado que se indica a continuación para que la bomba de filtración funcione por ciclos de 2 min cada hora en caso de que la temperatura de la piscina sea inferior al punto de consigna.



No conecte nunca la alimentación de la bomba de filtración directamente a los bornes 1 y 2.

6. ANEXOS (continuación)

6.3 Despiece y piezas de recambio

HP5081DT3LV / HP5111DT3LV / HP5151DT3LV

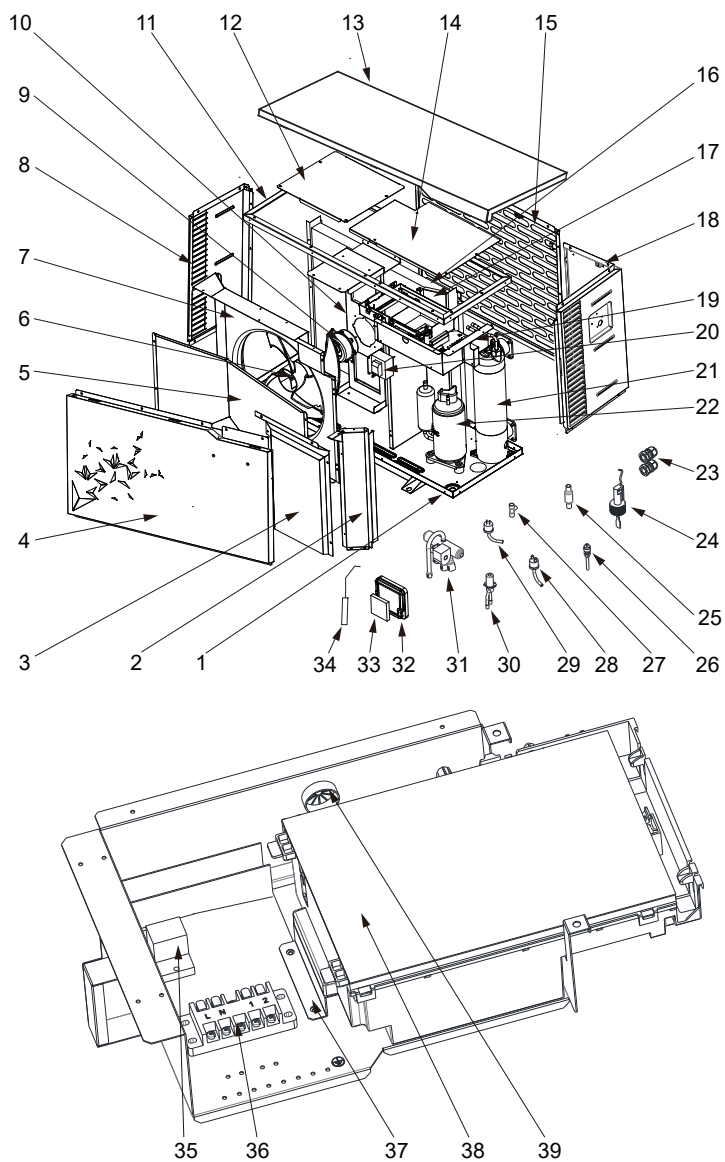

6. ANEXOS (continuación)

Rep	Designación	Ref.	HP5081DT3LV	HP5111DT3LV	HP5151DT3LV
1	/	/	/	/	/
2	/	/	/	/	/
3	/	/	/	/	/
4	Panel delantero	HWX80715842	✓	✓	n/a
		HWX80715857	n/a	n/a	✓
5	/	/	/	/	/
6	Hélice ventilador	HWX301030000006	✓	✓	n/a
		HWX20000270004	n/a	n/a	✓
7	/	/	/	/	/
8	Panel de la izquierda	HWX80713420	✓	✓	n/a
		HWX80713423	n/a	n/a	✓
9	Motor ventilador CC	HWX80200018	✓	✓	n/a
		HWX20000330132	n/a	n/a	✓
10	Soporte del motor	HWX80708597	✓	✓	n/a
		HWX80709977	n/a	n/a	✓
11	/	/	/	/	/
12	/	/	/	/	/
13	Panel superior	HWX80708601	✓	✓	n/a
		HWX80709984	n/a	n/a	✓
14	/	/	/	/	/
15	Panel posterior	HWX80710829	✓	✓	n/a
		HWX80710966	n/a	n/a	✓
16	Evaporador de aleta	HWX80600849	✓	n/a	n/a
		HWX80600781	n/a	✓	n/a
		HWX80600835	n/a	n/a	✓
17	/	/	/	/	/
18	Panel derecho	HWX80713421	✓	✓	n/a
		HWX80713424	n/a	n/a	✓
19	/	/	/	/	/
20	Reactancia	HWX82500020	✓	✓	n/a
		HWX82500021	n/a	n/a	✓
21	Condensador de titanio/PVC	HWX80600939	✓	n/a	n/a
		HWX80600940	n/a	✓	✓
		HWX80600096	n/a	n/a	✓
22	Compresor	HWX20000110448	✓	✓	n/a
		HWX80100046	n/a	n/a	✓
23	Prensaestopas	HWX20012249	✓	✓	n/a
		HWX20012238	n/a	n/a	✓
24	Detector del caudal de agua	HWX83000068	✓	✓	✓
25	Filtro Ø9.7-Ø9.7 (Ø19)	HWX20000140178	✓	✓	n/a
	Filtro Ø9.7-Ø9.7 (Ø28)	HWX20041444	n/a	n/a	✓
26	Toma de presión 40mm-1/2"	HWX20000140150	✓	✓	✓
27	Conector T Ø9.52-2 xØ6.35(T) x 1.0	HWX30403000002	✓	✓	n/a
	Conector T Ø6.5-2 x Ø6.5(T) x 0.75	HWX20001460	n/a	n/a	✓
28	Presostato baja presión NO 0.30MPa/0.15MPa	HWX20000360157	✓	✓	✓
29	Presostato de alta presión NC 3.2MPa/4.4MPa	HWX20013605	✓	✓	✓
30	Descompresor electrónico	HWX81000011	✓	✓	n/a
		HWX81000017	n/a	n/a	✓
31	Válvula 4 vías	HWX20041437	✓	✓	n/a
		HWX20000140485	n/a	n/a	✓
32	Soporte de controlador	HWX80901004	✓	✓	✓
33	Controlador LCD de Bluetooth	HWX72200312	✓	✓	✓

6. ANEXOS (continuación)

HP5081DT3LV / HP5111DT3LV / HP5151DT3LV

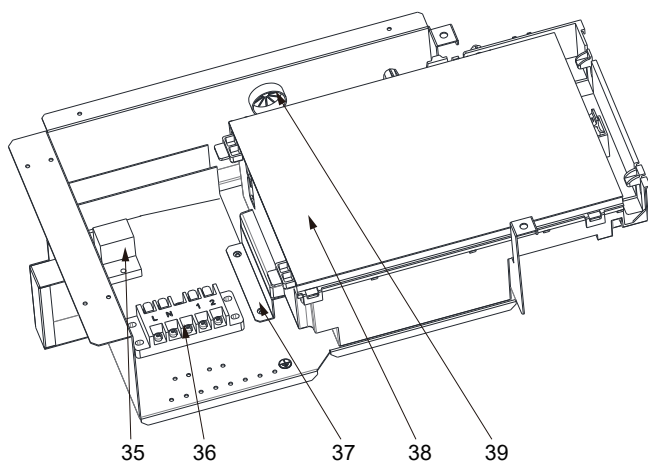
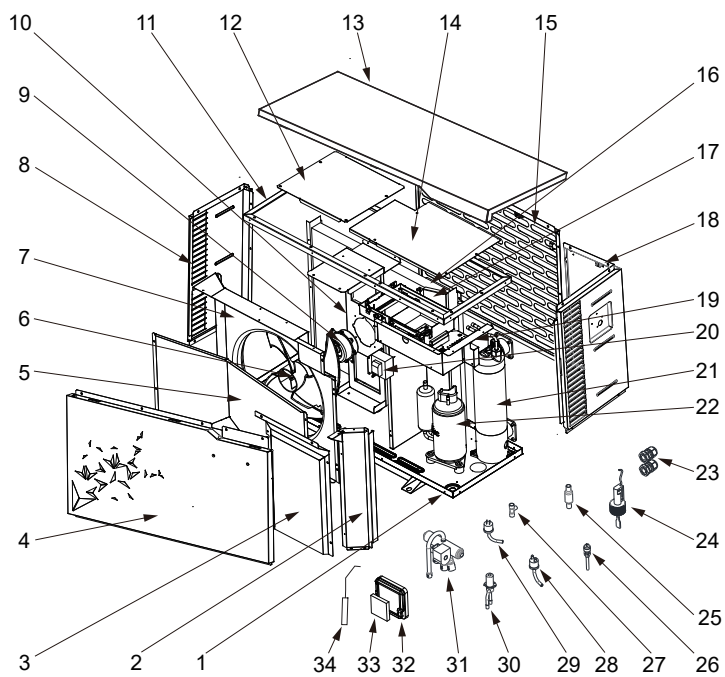

6. ANEXOS (continuación)

Rep	Designación	Ref.	HP5081DT3LV	HP5111DT3LV	HP5151DT3LV
34	Sonda de salida de agua 5k-410mm	HWX83000050	✓	✓	✓
	Sonda de entrada de agua 5k-850mm	HWX83000052	✓	✓	✓
	Sonda de descarga compresor 50k-660mm	HWX83000026	✓	✓	✓
	Sonda de aspiración compresor 5k-560mm	HWX83000044	✓	✓	n/a
	Sonda de aspiración compresor 5k-760mm	HWX83000053	n/a	n/a	✓
	Sonda de descongelación 5k-680mm	HWX83000051	✓	✓	n/a
	Sonda de descongelación 5k-1040mm	HWX83000045	n/a	n/a	✓
	Sonda de temperatura de aire Air 5k-350mm	HWX83000049	✓	✓	✓
35	Relé K2	HWX20000360297	✓	✓	✓
36	Borna L-N-GND -5 conexiones 4mm ²	HWX40003901	✓	✓	✓
37	/	/	/	/	/
38	Tarjeta electrónica Driver	HWX72200168SL08	✓	n/a	n/a
		HWX72200168SL11	n/a	✓	n/a
		HWX72200168SL15	n/a	n/a	✓
39	/	/	/	/	/

6. ANEXOS (continuación)

6.4 Guía de solución de averías



Algunas operaciones deben ser realizadas por un técnico habilitado.

En caso de fallo, las indicaciones siguientes aparecen en la pantalla.

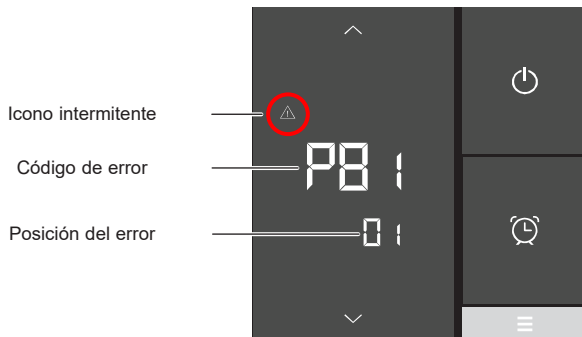

En caso de error, pulsar  o  para ver los códigos de error.
Consultar la tabla siguiente.



Después de resolver el problema, el error se eliminará automáticamente y el triángulo desaparecerá.

6. ANEXOS (continuación)

Fallo	Códigos de error	Descripción	Solución
Fallo de la sonda de entrada de agua (IT)	P01	El sensor está abierto o en cortocircuito	Comprobar la conexión en el conector alargador o sustituir el sensor
Fallo de la sonda de salida de agua (OT)	P02		
Fallo de la sonda de temperatura exterior (AT)	P04		
Fallo de la sonda de deshielo (CT)	P05		
Fallo de la sonda de aspiración del compresor (SUT)	P07		
Fallo de la sonda de descarga del compresor (ET)	P081		
Fallo de alta presión	E01	El sensor está abierto o en cortocircuito	<p>Comprobar la conexión en el conector alargador o sustituir el sensor</p> <p>Comprobar el caudal de agua</p> <p>Comprobar el detector del caudal de agua</p> <p>Comprobar la apertura de las válvulas</p> <p>Comprobar el by-pass</p> <p>Comprobar el estado de suciedad del evaporador</p> <p>Temperatura del agua demasiado caliente</p> <p>En caso de problema de incondensables tras un mantenimiento, vaciar y eliminar la humedad del circuito frigorífico</p> <p>Carga de fluido demasiado importante, retirar fluido en una botella de líquido</p>
Fallo de baja presión	E02	El sensor está abierto o en cortocircuito	<p>Comprobar la conexión en el conector alargador o sustituir el sensor</p> <p>Fuga importante de fluido frigorígeno, buscar la fuga con el detector</p> <p>Caudal de aire demasiado bajo, comprobar la velocidad de rotación del ventilador</p> <p>Comprobar el estado de suciedad del evaporador, limpiar la superficie</p>

6. ANEXOS (continuación)

Fallo	Códigos de error	Descripción	Solución
Fallo del detector de caudal	E03	El sensor está abierto o en cortocircuito	Comprobar la conexión CN29/OVT en la tarjeta o sustituir el sensor
			Falta de agua, comprobar el funcionamiento de la bomba de filtración
			Comprobar la apertura de las válvulas de parada
			Comprobar el ajuste del by-pass
Diferencia de temperatura Entrada/ Salida > 13 °C	E05	Aplicable en modo frío solamente	Falta de agua, comprobar el funcionamiento de la bomba de filtración
			Comprobar la apertura de las válvulas de parada
			Comprobar el ajuste del by-pass
Protección Antiheladas	E07	Temperatura de salida del agua < 4 °C	Detener la bomba de calor, vaciar el condensador de riesgo de heladas
Problema de comunicación	E08	Sin comunicación entre la tarjeta electrónica y la tarjeta de usuario	Comprobar las conexiones y los conectores - ver esquema eléctrico
Protección Antiheladas de nivel 1	E19	2 °C < Temperatura de agua < 4 °C y Temperatura de aire < 0 °C	Detener el funcionamiento de la bomba de calor, vaciar el condensador para evitar las heladas. De forma predeterminada, la bomba de calor activará la bomba de filtración para evitar la formación de hielo
Protección Antiheladas de nivel 2	E29	Temperatura del agua < 2 °C y Temperatura del aire < 0 °C	Detener el funcionamiento de la bomba de calor, vaciar el condensador para evitar las heladas. De forma predeterminada, la bomba de calor activará la bomba de filtración y la bomba de calor para evitar la formación de hielo.
Fallo del motor del ventilador	F03 I	Motor bloqueado o fallo de conexión	Comprobar la libre rotación; comprobar la conexión CN97/DCFan; sustituir el motor
Fallo del motor del ventilador	F05 I	Fallo de conexión	Comprobar la conexión DCFAN/CN97; sustituir el motor
Temperatura exterior demasiado baja	tP	Límite de funcionamiento alcanzado	Detener la bomba de calor
La bomba de calor no se pone en marcha	- - - 0FF	Contacto (5-6) Remote On/Off Abierto	Cerrar el contacto (5-6) Remote On/Off (ver esquema eléctrico)

6. ANEXOS (continuación)

6.5 Garantía

CONDICIONES DE GARANTÍA

Todos los productos HAYWARD están garantizados contra defectos de fabricación y material durante dos años a partir de la fecha de compra. Toda reclamación de garantía debe ir acompañada de una prueba de compra que justifique la fecha. A tal efecto, asegúrese de conservar su factura.

La garantía de HAYWARD se limita a la reparación o sustitución, a elección de HAYWARD, de los productos defectuosos, siempre que se hayan usado en condiciones normales, conforme a las recomendaciones e instrucciones del manual de uso, que no hayan sido objeto de modificación alguna y se hayan utilizado únicamente con componentes y piezas de HAYWARD. Los daños provocados por congelación y agentes químicos no están cubiertos por la garantía.

Todos los demás gastos (transporte, mano de obra, etc.) quedan excluidos de la garantía.

HAYWARD declina toda responsabilidad derivada de daños directos o indirectos causados por una instalación, una conexión o un uso incorrecto del producto.

Para usar la garantía y solicitar la reparación o sustitución de un artículo, póngase en contacto con su distribuidor. No se aceptarán envíos de material a nuestra fábrica sin nuestra aceptación previa por escrito.

Las piezas de desgaste no están cubiertas por la garantía.

Página en blanco intencionalmente



S.Line Pro *Fi*

BOMBA DE AQUECIMENTO PARA PISCINAS



Manual de instalação e de instruções

RESUMO

1. PREFÁCIO	1
2. CARACTERÍSTICAS TÉCNICAS	4
2.1 Dados técnicos da bomba de aquecimento	4
2.2 Período de funcionamento	5
2.3 Dimensões	6
3. INSTALAÇÃO E LIGAÇÃO	7
3.1 Esquema de princípio	7
3.2 Bomba de aquecimento	7
3.3 Ligação hidráulica	8
3.4 Ligação eléctrica	9
3.5 Primeira colocação em serviço	10
4. INTERFACE DO UTILIZADOR	12
4.1 Apresentação geral	12
4.2 Regulação do caudal de água	14
4.3 Ajuste do relógio	15
4.4 Ajuste dos temporizadores de Arranque/Paragem	15
4.5 Ajuste da função Timer (temporização) no modo SILÊNCIO	17
4.6 Emparelhamento Bluetooth - Controlo remoto	18
4.7 Escolha do modo de funcionamento	19
4.8 Regulação e visualização do ponto de ajuste	20
4.9 Bloqueio e desbloqueio do ecrã tátil	21
5. MANUTENÇÃO E PREPARAÇÃO PARA O INVERNO	22
5.1 Manutenção	22
5.2 Preparação para o Inverno	22
6. ANEXOS	23
6.1 Esquemas eléctricos	23
6.2 Ligações prioridade aquecimento bomba monofásica	25
6.3 Vistas explodidas e peças sobressalentes	26
6.4 Guia de resolução de problemas	30
6.5 Garantia	33

Ler atentamente e conservar para consulta posterior.

Este documento deve ser entregue ao proprietário da piscina e deve ser conservado por este em local seguro.

1. PREFÁCIO

Agradecemos-lhe pela compra desta bomba de calor para piscina Hayward. A bomba de calor S.LINE PRO foi concebida segundo estritas normas de fabrico para satisfazer os mais elevados níveis de qualidade requeridos.

As bombas de calor S.LINE PRO oferecem-lhe desempenhos excepcionais ao longo de toda a época de utilização da sua piscina, adaptando a potência, o consumo elétrico e o nível sonoro à sua necessidade de aquecimento, graças à lógica de controlo FULL INVERTER.



Leia atentamente as instruções deste manual antes de utilizar o aparelho.

As bombas de calor S.LINE PRO são exclusivamente destinadas a aquecer a água da piscina, não utilizar este material para outros fins.

O presente manual inclui todas as informações necessárias sobre a instalação, a eliminação de falhas de funcionamento e a conservação.

Leia atentamente este manual antes de abrir a unidade, ou realizar nesta operações de manutenção. O fabricante deste produto não será em caso algum responsável em caso de ferimento de um utilizador ou de deterioração da unidade consecutivos a eventuais erros aquando da instalação, da eliminação de falhas ou de uma manutenção inútil. É fundamental seguir em todas as ocasiões as instruções especificadas neste manual.

Toda recomendação não respeitada anula a garantia.

1. PREFÁCIO (continuação)



Instruções de segurança



Este aparelho contém R32.

Jamais utilizar um refrigerante diferente do R32. A mistura de qualquer outro elemento gasoso com o R32 pode provocar pressões anormalmente elevadas, suscetíveis de provocar uma avaria ou a rutura de tubos e possíveis ferimentos de pessoas. Aquando os reparos ou operações de manutenção, use tubos de cobre em conformidade com a Norma EN 12375-1 (maio de 2020) e a Diretiva Europeia de Equipamentos de Pressão 97/23 / EC. A bomba de calor está sob pressão, portanto jamais perfurar os tubos nem tentar efetuar uma brasagem. Há um risco de explosão.

Nunca expor o aparelho a chamas, faíscas ou qualquer outra fonte de ignição. Este poderia explodir e causar ferimentos graves ou mesmo mortais.



A bomba de calor foi exclusivamente prevista para uma instalação ao exterior dos edifícios.

- Em caso de armazenamento da bomba de calor, esta deve ser armazenada num local corretamente ventilado que tenha uma superfície no solo superior a A_{\min} (m²), estabelecida pela seguinte fórmula: $A_{\min} = (M / (2,5 \times 0,22759 \times h_0))^2$ M sendo a carga de refrigerante no aparelho em kg e h₀ a altura de armazenamento. Para um armazenamento no solo h₀ = 0,6 m.
- A unidade deve ser instalada por pessoal qualificado.
- Não instalar a bomba de calor sobre um suporte suscetível de amplificar as vibrações da unidade.
- Verificar que o suporte previsto para a unidade foi adequadamente dimensionado para o peso do aparelho.
- Não instalar a bomba de calor num lugar suscetível de amplificar o seu nível sonoro ou num lugar onde o ruído da unidade possa incomodar a vizinhança.
- Todas as ligações elétricas devem ser efetuadas por um electricista profissional qualificado e de acordo com as normas em vigor no país de instalação, ver § 3.4.
- Cortar a alimentação principal e o seccionador antes de qualquer trabalho elétrico. Qualquer esquecimento pode ser causa de eletrocussão.
- Antes da instalação, verificar que o cabo de ligação à terra não foi cortado ou desconetado.

1. PREFÁCIO (continuação)

- Conetar e apertar adequadamente o cabo de alimentação elétrica. Se a ligação for incorreta, partes elétricas podem ser danificadas.
- A exposição da bomba de calor à água ou a um ambiente húmido pode provocar uma eletrocussão. Mantenha-se extremamente vigilante.
- Se detetar qualquer defeito ou situação anormal, não instale a bomba de calor e contate imediatamente o seu revendedor.
- A manutenção e as diferentes operações devem ser realizadas conforme a frequência e os momentos recomendados, tal como especificado no presente manual.
- As reparações devem ser efetuadas por pessoal qualificado.
- Utilizar somente peças sobressalentes originais.
- Jamais utilizar um outro processo de limpeza que não seja o preconizado neste manual.

Informações importantes relativas ao refrigerante utilizado.

Este produto contém gases fluorados com efeito de estufa que são enquadrados pelo protocolo de Quioto. Não libertar estes gases na atmosfera.

Tipo de refrigerante: R32

Valor GWP(1): 675, Valor baseado no 4º relatório do GIEC.

A quantidade de refrigerante baseada na regulamentação F-Gás n.º 517/2014 está indicada na placa de identificação da unidade.

Inspeções periódicas de fuga de refrigerante podem ser exigidas em função da legislação europeia ou local. Queira contactar o seu distribuidor local para mais amplas informações.

(1) Potencial de aquecimento global

2. CARACTERÍSTICAS TÉCNICAS

2.1 Dados técnicos da bomba de aquecimento

Modelos	S.LINE PRO	HP5081DT3LV	HP5111DT3LV	HP5151DT3LV
Tensão de alimentação	V	220V-240V ~ / 1fase / 50Hz		
Refrigerante	/	R32		
Carga	kg	0,45	0,50	0,65
Massa em tCO ₂ eq	/	0,30	0,34	0,44
Frequência de controlo de fuga	/	Nenhuma exigência mas é recomendado que esta seja anual		
Capacidade de aquecimento Mín--Máx ^(a)	kW	2,83 -- 8,16	1,95 -- 10,90	5,27 -- 15,66
Potência elétrica absorvida Mín--Máx ^(a)	kW	0,212 -- 1,19	0,150 -- 1,92	0,457 -- 2,80
Corrente nominal de serviço Mín--Máx ^(a)	A	1,41 -- 5,20	1,05 -- 8,49	2,04 -- 12,28
COP (coeficiente de desempenho) Máx--Mín ^(a)	/	13,30 -- 6,81	12,92 -- 5,67	11,53 -- 5,59
Capacidade de aquecimento Mín--Máx ^(b)	kW	1,77 -- 5,91	1,86 -- 8,40	3,81 -- 11,67
Potência elétrica absorvida Mín--Máx ^(b)	kW	0,31 -- 1,28	0,30 -- 1,83	0,588 -- 2,71
COP (coeficiente de desempenho) Máx--Mín ^(b)	/	5,70 -- 4,62	6,20 -- 4,59	6,48 -- 4,31
Corrente máxima de serviço (CMS)	A	6,50	10,30	14
Calibre do fusível	gG	10	12	16
Disjuntor curva C	C	10	12	16
Corrente de arranque	A	< CMS		
Ligação hidráulica	mm	50 mm		
Caudal de água nominal ^(a)	m ³ /h	3,50	4,60	6,70
Perda de carga na água máx	kPa	8	5	10
Compressor	/	DC Inverter MITSUBISHI ELECTRIC		DC Inverter Mitsubishi
Tipo	/	Duplo Rotativo		Duplo Rotativo
Quantidade	/	1		
Resistência de enrolamento a 20°C	Ohm	1,91 +/- 5%		0,95 +/- 5%
Ventilador	/	Axial		
Quantidade	/	1		
Diâmetro	mm	405	500	
Número de pás	/	3		
Motor	/	DC Inverter		
Quantidade	/	1		
Velocidade de rotação	Rpm	500 -- 800	500 -- 900	500 -- 750
Velocidade Modo Silêncio	Rpm	500	500	500
Nível de pressão acústica a 1 m	dB(A)	45,1	48,6	54,1
Nível de pressão acústica a 10 m	dB(A)	27,9	31,6	36,9
Dimensões (sem embalagem) da unidade (C-L-A)	mm	1003 / 418 / 605		1048 / 437 / 768
Peso	kg	61	61	87



(a) Ar seco 27°C - Humidade relativa 78% - Temperatura de entrada da água 26°C.

(b) Ar seco 15°C - Humidade relativa 71% - Temperatura de entrada da água 26°C

2. CARACTERÍSTICAS TÉCNICAS (continuação)

2.2 Período de funcionamento

Utilizar a bomba de aquecimento nos seguintes intervalos de temperatura e humidade para assegurar um funcionamento seguro e eficaz.

	Modo de aquecimento 	Modo de Refrigeração 
Temperatura exterior	-7°C – +35°C	+7°C – +43°C
Temperatura da água	+12°C – +32°C	+8°C – +40°C
Humidade relativa	< 80%	< 80%
Intervalo de Ajuste do ponto de afinação	+15°C – +32°C	+8°C – +32°C



Se a temperatura e a humidade não corresponderem a estas condições, podem disparar os dispositivos de segurança e a bomba de aquecimento pode deixar de funcionar.



A temperatura máxima de aquecimento é limitada à 32°C a fim de evitar a deterioração dos liners. Hayward declina qualquer responsabilidades em caso de utilização que ultrapassa os +32°C.

2. CARACTERÍSTICAS TÉCNICAS (continuação)

2.3 Dimensões

Modelos:

HP5081DT3LV / HP5111DT3LV / HP5151DT3LV

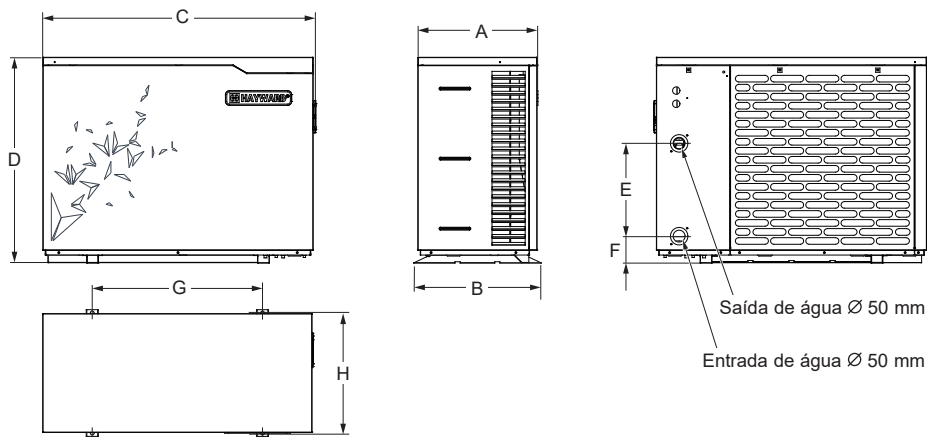

Unidade : mm

Referência \ Tipo	HP5081DT3LV / HP5111DT3LV	HP5151DT3LV
A	393	453
B	430	480
C	1011	1030
D	621,5	776
E	350	350
F	97,5	102
G	625	645
H	406	456

3. INSTALAÇÃO E LIGAÇÃO

3.1 Esquema de princípio

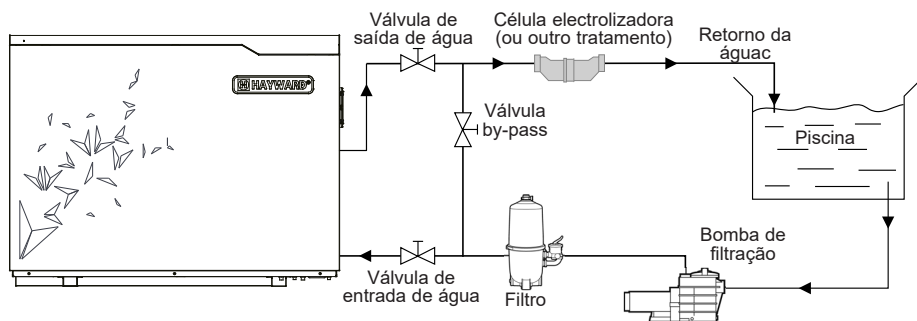

Nota: A bomba de aquecimento é fornecida sem qualquer equipamento de tratamento ou filtração. Os elementos presentes no esquema são peças a fornecer pelo instalador.

3.2 Bomba de aquecimento



Colocar a bomba de aquecimento no exterior e fora de qualquer local técnico fechado.

Colocada sob abrigo, devem ser respeitadas as distâncias mínimas prescritas abaixo a fim de evitar qualquer risco de recirculação de ar e de degradação dos desempenhos globais da bomba de aquecimento.

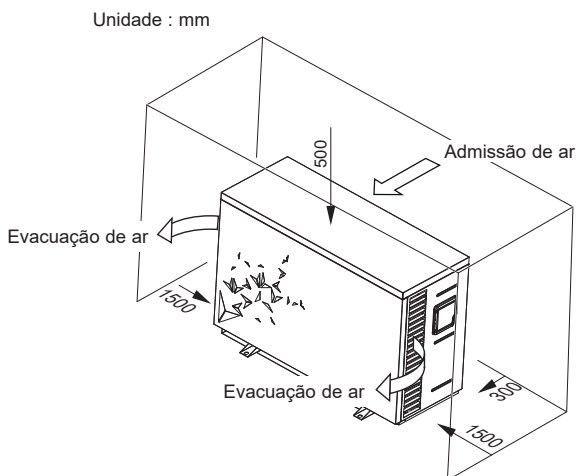

3. INSTALAÇÃO E LIGAÇÃO (continuação)



Instalar de preferência a bomba de calor sobre uma laje de betão dessolidarizada ou uma caixa de fixação prevista para este efeito e montar a bomba de aquecimento sobre os blocos amortecedores fornecidos (parafusos e anilhas não fornecidos).

Distância máxima de instalação entre a bomba de aquecimento e a piscina 15 metros.

Comprimento total ida e volta das canalizações hidráulicas 30 metros.

Isolar as canalizações hidráulicas de superfície e enterradas.

A bomba de calor deve ser instalada a uma distância mínima da piscina de acordo com a norma NF C 15-100 (ou seja, a 3,5 m da massa de água, em França) ou com as normas de instalação em vigor noutros países.

Não instalar a bomba de calor junto a fontes de calor.

Em caso de instalação em regiões com ocorrência de neve, recomenda-se manter a máquina abrigada para evitar a acumulação de neve no evaporador.

3.3 Ligação hidráulica

A bomba de aquecimento é fornecida com duas uniões de 50 mm de diâmetro. Utilizar tubo PVC para canalização hidráulica Ø 50 mm. Ligar a entrada de água da bomba de aquecimento à conduta proveniente do grupo de filtração e, em seguida, ligar a saída de água da bomba de aquecimento à conduta de água que segue para a bacia (consultar esquema abaixo).

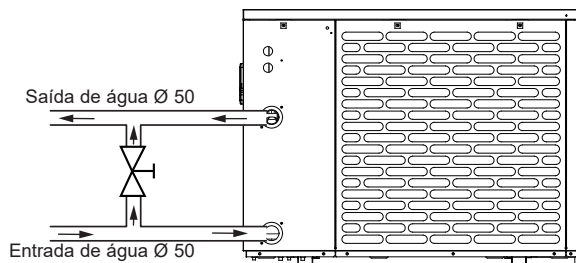

Instalar uma válvula dita de “by-pass” entre a entrada e a saída da bomba de aquecimento.



Se for utilizado um distribuidor automático, deve obrigatoriamente ser instalado após a bomba de aquecimento a fim de proteger o condensador Titane contra uma concentração demasiado elevada de produto químico.



Tenha o cuidado de instalar a bomba de by-pass e as uniões fornecidas ao nível de entrada e saída de água da unidade, a fim de simplificar a purga durante o período de Inverno, facilitar o acesso ou a respectiva desmontagem para manutenção.

3. INSTALAÇÃO E LIGAÇÃO (continuação)

3.4 Ligação eléctrica



A instalação eléctrica e a cablagem deste equipamento devem estar em conformidade com a regras de instalação locais em vigor.

F	NF C15-100	GB	BS7671:1992
D	DIN VDE 0100-702	EW	EVHS-HD 384-7-702
A	ÖVE 8001-4-702	H	MSZ 2364-702/1994/MSZ 10-553 1/1990
E	UNE 20460-7-702 1993, RECBT ITC-BT-31 2002	M	MSA HD 384-7-702.S2
IRL	Regras de cablagem + IS HD 384-7-702	PL	PN-IEC 60364-7-702:1999
I	CEI 64-8/7	CZ	CSN 33 2000 7-702
LUX	384-7.702 S2	SK	STN 33 2000-7-702
NL	NEN 1010-7-702	SLO	SIST HD 384-7-702.S2
P	RSIUEE	TR	TS IEC 60364-7-702



Verifique que a alimentação eléctrica disponível e a frequência da rede correspondem à corrente de funcionamento requerida, tendo em conta a localização específica do equipamento, e a corrente necessária para alimentar qualquer outro aparelho ligado ao mesmo circuito.

**HP5081DT3LV / HP5111DT3LV / HP5151DT3LV
230V \sim +/- 10 % 50 Hz 1 Fase**

**Observe o esquema de cablagem correspondente em anexo.
Três ligações destinam-se à alimentação eléctrica, e duas ao comando da bomba de filtração (Servocomando).**

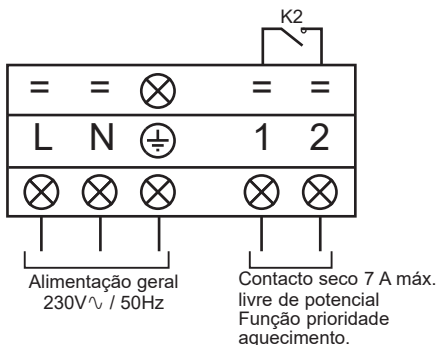

3. INSTALAÇÃO E LIGAÇÃO (continuação)



A linha de alimentação eléctrica deve ser dotada, de maneira apropriada, de um dispositivo de protecção fusível do tipo alimentação de motor (gG) ou disjuntor curvo C bem como de um disjuntor diferencial de 30mA (ver tabela anexa).

Modelos		HP5081DT3LV	HP5111DT3LV	HP5151DT3LV
Alimentação eléctrica	V/Ph/ Hz	230V~ 50Hz	230V~ 50Hz	230V~ 50Hz
Calibre fusível tipo gG	A	10 gG	12 gG	16 gG
Disjuntor curvo C	A	10 C	12 C	16 C
Secção de cabo	mm ²	3G 2,5	3G 2,5	3G 2,5



Utilizar o cabo de alimentação do tipo RO 2V / R 2V ou equivalente.



As secções de cabo são fornecidas para um comprimento máximo de 25 m. Devem no entanto ser verificadas e adaptadas em função das condições de instalação.



Tenha sempre o cuidado de interromper a alimentação principal antes de abrir a caixa de comando eléctrico.

3.5 Primeira colocação em serviço

Procedimento de arranque - uma vez a instalação terminada, seguir e respeitar as etapas seguintes:

- 1) Faça girar os ventiladores com a mão a fim de verificar que ele pode girar livremente com a mão, e que a hélice está fixada correctamente sobre o eixo do motor.
- 2) Assegure-se que a unidade está correctamente ligada à alimentação principal (ver esquema de cablagem em anexo).
- 3) Active a bomba de filtração.
- 4) Verifique que todas as válvulas de água estão abertas, e que a água flui para a unidade antes de passar ao modo de aquecimento ou refrigeração.
- 5) Verifique que o tubo de purga de condensados está correctamente fixado e não apresenta nenhuma obstrução.
- 6) Active a alimentação eléctrica destinada à unidade, depois prima a tecla Marche/Arrêt (Marcha/Paragem)  no painel de comando.

3. INSTALAÇÃO E LIGAÇÃO (continuação)

- 7) Certifique-se de que os símbolos de alarme ou de bloqueio não são visualizados. Se for o caso, consultar o guia de resolução de problemas (consulte a secção 6.4).
- 8) Fixe o débito de água com a ajuda da válvula de by-pass (ver § 2.1 e 4.2), conforme previsto respectivamente para cada modelo, de modo a obter uma diferença de temperatura Entrada/Sáida de 2°C.
- 9) Após um funcionamento de alguns minutos, verifique que o ar que sai da unidade é refrigerado (entre 5°C e 10°C).
- 10) Com a unidade em serviço, desactive a bomba de filtração. A unidade deve parar automaticamente e apresentar o código de erro E03.
- 11) Faça funcionar a unidade e a bomba da piscina 24 horas sobre 24, até que seja atingida a temperatura da água pretendida. Quando a temperatura de entrada de água atingir o valor de afinação, a unidade pára. Volta então a arrancar automaticamente (desde que a bomba da piscina esteja em serviço) se a temperatura da piscina for inferior em pelo menos 0,5°C à temperatura regulada.

Controlador de débito - A unidade é dotada de um controlador de débito que activa a bomba de calor quando a bomba de filtração da piscina está em serviço, e desactiva-a quando a bomba de filtração está fora de serviço. Por falta de água, aparece no regulador o código de alarme E03 (Ver § 6.4).

Temporização - a unidade integra uma temporização de 3 minutos, a fim de proteger os componentes do circuito de comando, eliminar qualquer instabilidade em termos de re-arranque e qualquer interferência ao nível do contactor. Graças a esta temporização, a unidade voltar a arrancar automaticamente cerca de 3 minutos após qualquer corte do circuito de comando. Mesmo um corte de corrente de curta duração activa a temporização de arranque.

4. INTERFACE DO UTILIZADOR

4.1 Apresentação geral

A bomba de aquecimento está equipada com um painel de comando digital com ecrã táctil, ligado electricamente e pré-regulado de fábrica em modo de aquecimento.

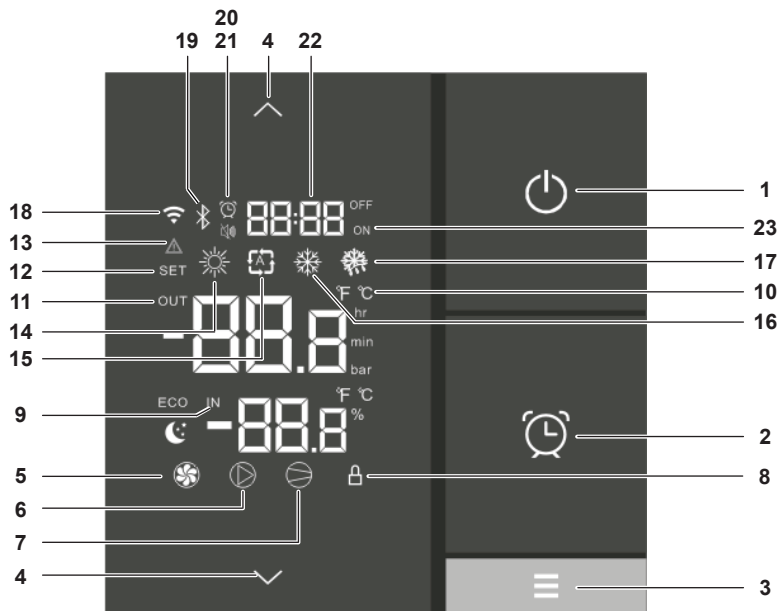

Legenda

1		Arranque/Paragem/Cancelamento
2		Regulação da hora e Temporizador
3		Escolha do modo de funcionamento
4		Rolar para cima / para baixo, +°C / -°C
5		Ventilador ON
6		Contacto seco OUT2 ON
7		Compressor ON
8		Ecrã bloqueado
9		Entrada de água
10		Celsius / Fahrenheit
11		Saída de água
12		Configurações avançadas

13		Falha do sistema
14		Modo de aquecimento
15		Modo automático
16		Modo de refrigeração
17		Modo de descongelamento
18		N/A
19		Ligação Bluetooth
20		Temporizador programado
21		Indicador do modo silêncio / Temporizador
22		Hora / Hora dos temporizadores
23		Temporizador programado para Paragem e Arranque

4. INTERFACE DO UTILIZADOR (continuação)

Modo OFF/PARAGEM

Quando a bomba de calor está no modo de espera (Modo OFF), aparece no ecrã do regulador a inscrição “OFF” e o ecrã muda para o modo de poupança de energia após um minuto.

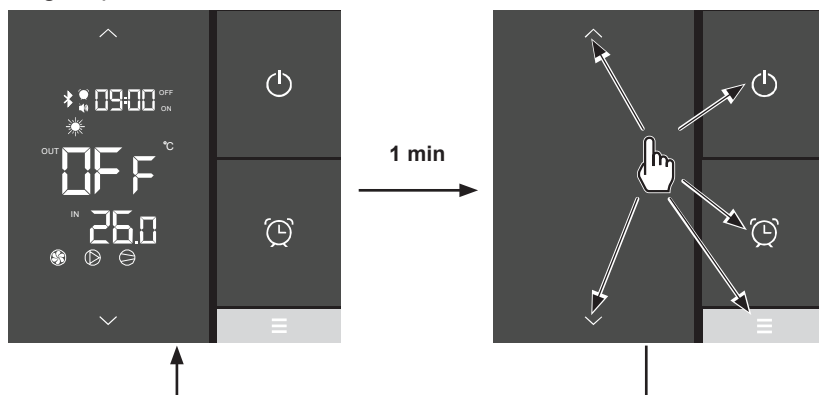

Para voltar ao ecrã completo, premir qualquer botão.

Modo ON

Quando a bomba de calor está em funcionamento ou em regulação (Modo ON) as temperaturas de entrada e de saída de água são apresentadas no ecrã do regulador e o ecrã muda para o modo de poupança de energia após um minuto.

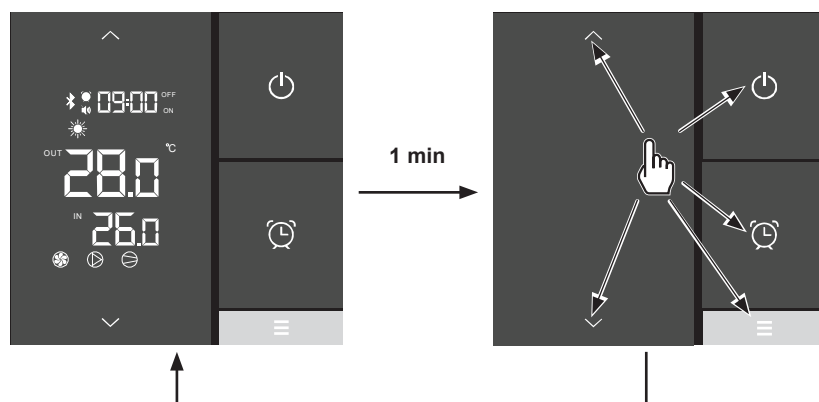

Para voltar ao ecrã completo, premir qualquer botão.

4. INTERFACE DO UTILIZADOR (continuação)

4.2 Regulação do caudal de água

Com as válvulas de entrada e saída de água abertas, ajustar a válvula de “by-pass” de modo a obter uma diferença de 2°C entre a temperatura de entrada e saída de água (ver esquema de princípio § 3.1).

Pode verificar o ajuste visualizando as temperaturas de entrada/saída directamente no painel de comando através do procedimento abaixo.



Em seguida, ajuste o seu By-pass para obter uma diferença de 2°C entre a entrada e a saída.

Prima  para sair do menu.

- A abertura da válvula “by-pass” provoca um caudal mais baixo no permutador da bomba de calor, aumentando assim a diferença de temperatura de entrada/saída.
- O fecho da válvula “by-pass” provoca um caudal mais alto no permutador da bomba de calor e, por conseguinte, uma menor diferença de temperatura de entrada/saída.

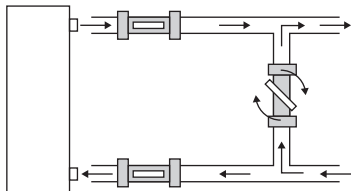

A regulação pode ser verificada através da visualização das temperaturas de entrada/saída (1-2) directamente na aplicação “EyesPool Inverter Connect” (ver § 4.6).











4. INTERFACE DO UTILIZADOR (continuação)

4.3 Ajuste do relógio

No final dos ajustes, pressionar  para confirmar.

Os ajustes são automaticamente memorizados após 5 segundos sem ação.













- Pressionar  o mostrador da hora fica intermitente.
- Pressionar  o mostrador da hora fica intermitente. Ajustar as horas com os botões  e .
- Pressionar  e, depois, ajustar os minutos com os botões  e .
- Validar pressionando .

4.4 Ajuste dos temporizadores de Arranque/Paragem

O ajustamento desta função será necessário se desejar utilizar a bomba de calor ao longo de um período mais curto do que o definido pelo relógio de filtração. Deste modo, poderá programar um arranque diferido e uma paragem antecipada ou simplesmente proibir uma faixa horária de funcionamento (por exemplo, à noite).

Podem programar um temporizador de arranque (ON) e um temporizador de paragem (OFF).

Programação do temporizador - Arranque (ON)

- Pressionar  durante 2 segundos, até que o ícone  pisque.
- Pressionar , o mostrador fica  intermitente (.
- Pressionar  para ajustar as horas com os botões  e .
- Pressionar  para ajustar os minutos com os botões  e .
- Validar pressionando  e depois premir  para voltar ao ecrã principal.

















A salvaguarda dos ajustamentos é automática após 20s sem ação.

Os minutos são definidos em incrementos de 10 minutos

A indicação ON sob o mostrador de hora no ecrã principal indica que o Temporizador de Arranque (ON) está programado.

4. INTERFACE DO UTILIZADOR (continuação)

Programação do temporizador - Paragem (OFF)







- Pressionar  durante 2 segundos, até que o ícone  pisque
- Pressionar , o mostrador fica  intermitente ().
- Pressionar , o mostrador fica  intermitente ().
- Pressionar  para ajustar as horas com os botões  e .
- Pressionar  para ajustar os minutos com os botões  e .
- Validar pressionando  e depois premir  para voltar ao ecrã principal.

A salvaguarda dos ajustamentos é automática após 20s sem ação.

Os minutos são definidos em incrementos de 10 minutos







A indicação OFF que aparece acima da hora no ecrã principal indica que o temporizador OFF está programado.

Consulta de Temporizadores







- Pressionar  durante 2 segundos, até que o ícone  pisque.
- Pressionar , o mostrador da hora de arranque fica  intermitente.
- Pressionar , o mostrador da hora de paragem fica  intermitente.
- Pressionar  para voltar ao ecrã principal.

O ícone  é exibido no ecrã principal quando um temporizador de arranque e/ou um temporizador de paragem é programado.

Eliminação dos Temporizadores de Arranque (ON) e de Paragem (OFF)









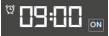

- Pressionar  durante 2 segundos, até que o ícone  pisque.
- Pressionar 2 vezes , as horas de arranque ficam intermitentes .
- Pressionar  para eliminar o temporizador de arranque .

No final da etapa 3 pressionar  para voltar ao ecrã principal ou avançar para a etapa 4 para continuar.

- Pressionar  para aceder à hora de paragem .
- Pressionar , as horas de paragem ficam intermitentes .
- Pressionar  para eliminar o temporizador de paragem .
- Pressionar  para voltar ao ecrã principal.

4. INTERFACE DO UTILIZADOR (continuação)

















Eliminação do temporizador de Paragem (OFF)

- Pressionar  durante 2 segundos, até que o ícone  pisque.
- Pressionar 2 vezes , as horas de arranque ficam intermitentes .
- Pressionar  para aceder à hora de paragem .
- Pressionar , as horas de paragem ficam intermitentes .
- Pressionar  para eliminar o temporizador de paragem .
- Pressionar  para voltar ao ecrã principal.











4.5 Ajuste da função Timer (temporização) no modo SILÊNCIO

O modo SILÊNCIO permite utilizar a bomba de calor em modo económico e muito silencioso quando as necessidades de aquecimento são baixas (manter a temperatura da piscina ou assegurar o funcionamento ultra silencioso).

Programação do temporizador no modo SILÊNCIO

- Pressionar  durante 2 segundos, até que o ícone  pisque.
- Pressionar , o ícone  fica intermitente.
- Pressionar , o mostrador fica  intermitente.
- Pressionar  para ajustar a hora de arranque com os botões  e .
- Pressionar  e , o mostrador fica  intermitente.
- Pressionar  para ajustar a hora de paragem com os botões  e .
- Pressionar  para validar e  para voltar ao ecrã principal.

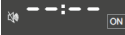
Eliminação do timer (temporizador) no modo SILÊNCIO







- Pressionar  durante 2 segundos, até que o ícone  pisque.
- Pressionar , o ícone  fica intermitente.
- Pressionar , o mostrador da hora de arranque fica  intermitente.
- Pressionar , apenas as horas piscam.
- Pressionar , o mostrador fica  intermitente.
- Pressionar  para voltar ao ecrã principal.

A eliminação do Temporizador de Arranque irá apagar automaticamente o Temporizador de Paragem.

O ciclo de configuração é feito “de hora a hora”.

4. INTERFACE DO UTILIZADOR (continuação)

Consulta do temporizador no modo silêncio

- Pressionar  durante 2 segundos, até que o ícone  pisque.
- Pressionar , o ícone  fica intermitente.
- Pressionar  para visualizar a hora de arranque.
- Pressionar  para visualizar a hora de paragem.
- Pressionar  para voltar ao ecrã principal.

Quando o ícone  é exibido no ecrã principal, um temporizador de arranque e/ou um temporizador de paragem é programado para o modo SILÊNCIO.

4.6 Emparelhamento Bluetooth - Controlo remoto

A bomba de calor está equipada com a função Bluetooth.

Graças à aplicação “*EyesPool Inverter Connect*”, pode usar o seu smartphone como controlo remoto para controlar a sua bomba de calor dentro de um limite de 10 m em campo livre.

Para utilizar esta função  **Bluetooth**:

- ▶ Descarregue a aplicação “*EyesPool Inverter Connect*” gratuitamente em

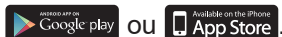

- ▶ Crie uma conta na aplicação.
- ▶ Siga as instruções do vídeo (links abaixo) para emparelhar o seu smartphone com a bomba de calor:
<https://www.hayward.fr/article/tutoriels-hayward/s-line-pro-bluetooth-appairage>



4. INTERFACE DO UTILIZADOR (continuação)

4.7 Escolha do modo de funcionamento

Aquecimento - Automático - Refrigeração



Se a bomba de calor for ajustada para o modo Apenas Aquecimento ou Apenas Frio pelo instalador, a mudança de modo não estará disponível.

Premir o botão  para mudar de modo: Aquecimento - Automático - Refrigeração.

Aquecimento

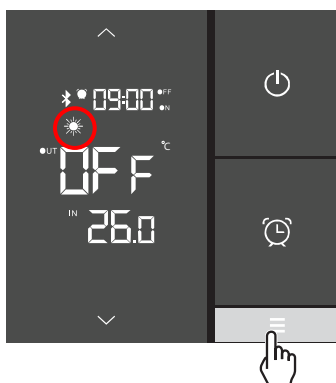

Automático



Refrigeração







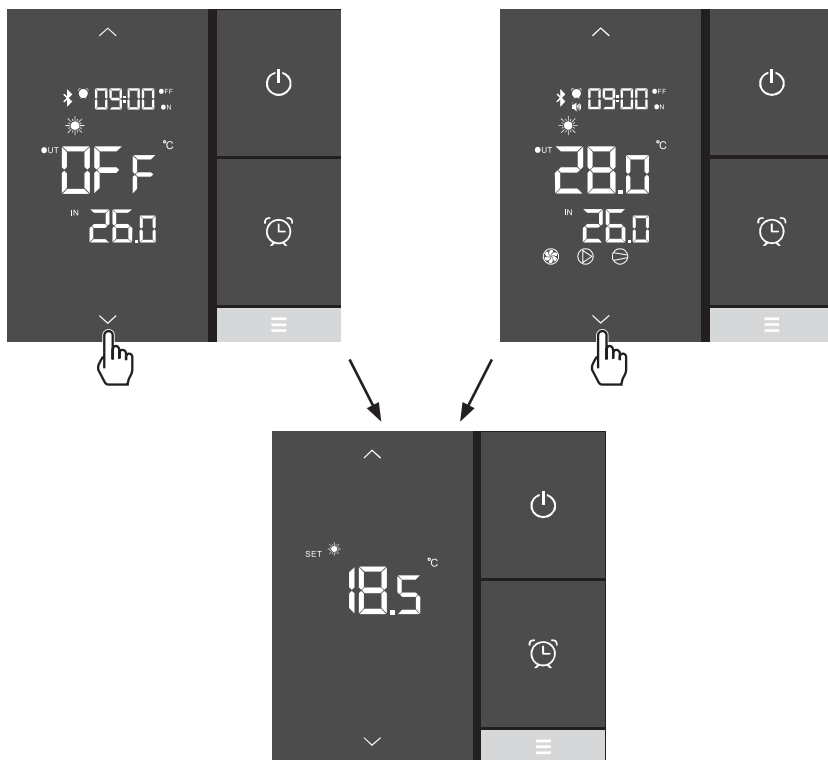

4. INTERFACE DO UTILIZADOR (continuação)

4.8 Regulação e visualização do ponto de ajuste

Temperatura da água pretendida

A regulação do ponto de ajuste efetua-se em modo OFF ou ON com uma precisão de 0,5°C.



- Pressionar  ou  para que o ponto de ajuste fique intermitente.
- Pressionar  ou  para definir o ponto de ajuste pretendido.
- Pressionar  para validar ou  para cancelar.

Os ajustes são automaticamente memorizados após 5 segundos sem ação.







Nunca deve exceder a temperatura de 30°C para evitar a alteração dos liners.

4. INTERFACE DO UTILIZADOR (continuação)

4.9 Bloqueio e desbloqueio do ecrã tátil

O ecrã pode ser bloqueado e desbloqueado tanto no modo ON como OFF.

- Pressionar  durante 5 segundos até visualizar o ícone .
- Para desbloquear, pressione  até que o ícone  desapareça.

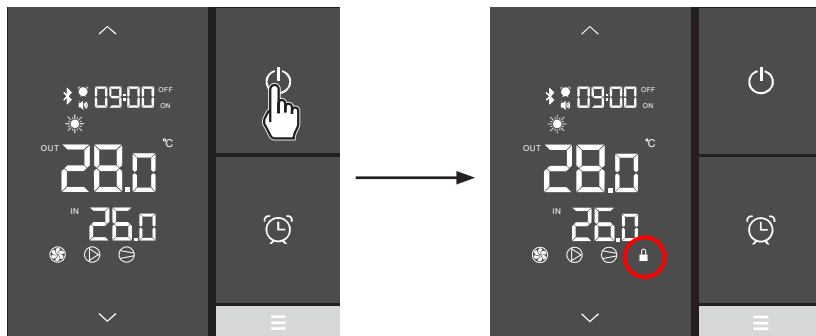

5. MANUTENÇÃO E PREPARAÇÃO PARA O INVERNO

5.1 Manutenção

Estas operações de manutenção devem ser realizadas 1 vez por ano a fim de garantir a longevidade e o bom funcionamento da bomba de aquecimento.

- Limpar o evaporador com a ajuda de uma escova macia ou jacto de ar ou água (**Atenção, nunca utilizar um aspersor de alta pressão**).
- Verificar o bom escoamento dos condensados.
- Verificar o aperto das ligações hidráulicas e eléctricas
- Verificar a estanqueidade hidráulica do condensador.
- **Solicitar a um profissional** com formação que verifique a impermeabilidade do circuito frigorífico através do detetor de fugas.



Antes de qualquer operação de manutenção a bomba de aquecimento deve ser desligada de qualquer fonte de corrente eléctrica. As operações de manutenção devem ser realizadas unicamente por pessoal qualificado e habilitado para manipular fluidos de refrigeração.

5.2 Preparação para o Inverno

- Colocar a bomba de aquecimento em Modo “OFF”.
- Cortar a alimentação da bomba de aquecimento.
- Esvaziar o condensador com a ajuda do dreno para evitar qualquer risco de degradação. (risco importante de congelação).
- Fechar a válvula de “by-pass” e desapertar as uniões de entrada/saída.
- Expulsar ao máximo a água residual do condensador com a ajuda de uma pistola de ar.
- Obturar a entrada e a saída de água na bomba de aquecimento para evitar a entrada de corpos estranhos.
- Cobrir a bomba de aquecimento com a capa de Inverno prevista para este efeito.



Qualquer dano ocasionado por deficiente preparação para o Inverno implica a anulação da garantia.

6. ANEXOS

6.1 Esquemas eléctricos

HP5081DT3LVM / HP5111DT3LV

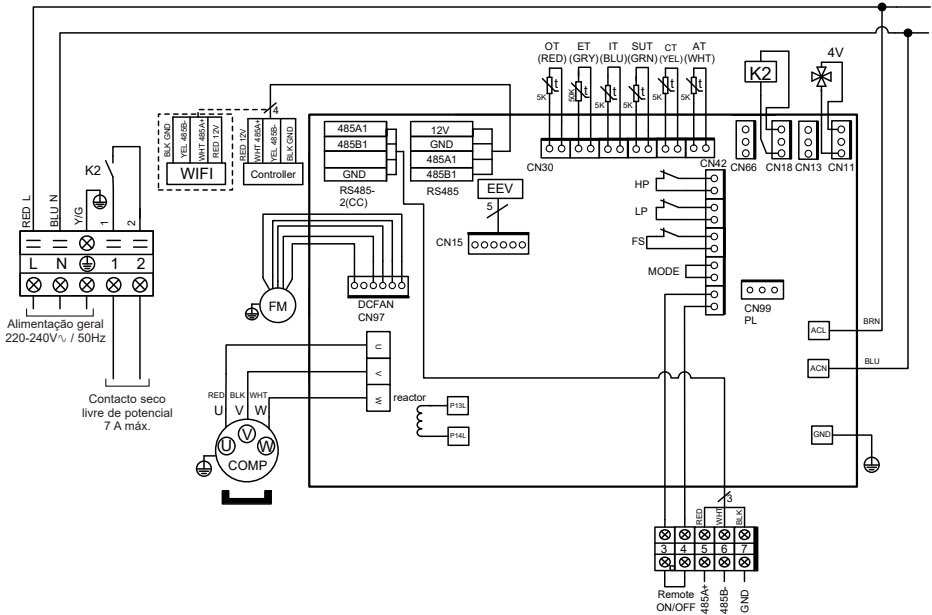

LEGENDA

- | | |
|--|--|
| AT : SONDA DE TEMPERATURA DO AR | LP : PRESSÓSTATO BAIXA PRESSÃO |
| COMP : COMPRESSOR | OT : SONDA DE TEMPERATURA SAÍDA DE ÁGUA |
| CT : SONDA TEMPERATURA EVAPORADOR | SUT : SONDA DE TEMPERATURA DE ASPIRAÇÃO |
| EEV : REGULADOR ELECTRÓNICO | 4V : VÁLVULA DE 4 VIAS |
| FM : MOTOR VENTILADOR | K2 : CONTACTO SECO LIVRE DE POTENCIAL 7 A MÁX |
| FS : DETECTOR PRESENÇA DE ÁGUA | ET : SONDA DE TEMPERATURA DE DESCARGA |
| HP : PRESSÓSTATO ALTA PRESSÃO | ET : SONDA DE TEMPERATURA DE DESCARGA |
| IT : SONDA DE TEMPERATURA ENTRADA DE ÁGUA | ET : SONDA DE TEMPERATURA DE DESCARGA |
- : OPÇÃO

6. ANEXOS (continuação)

HP5151DT3LV

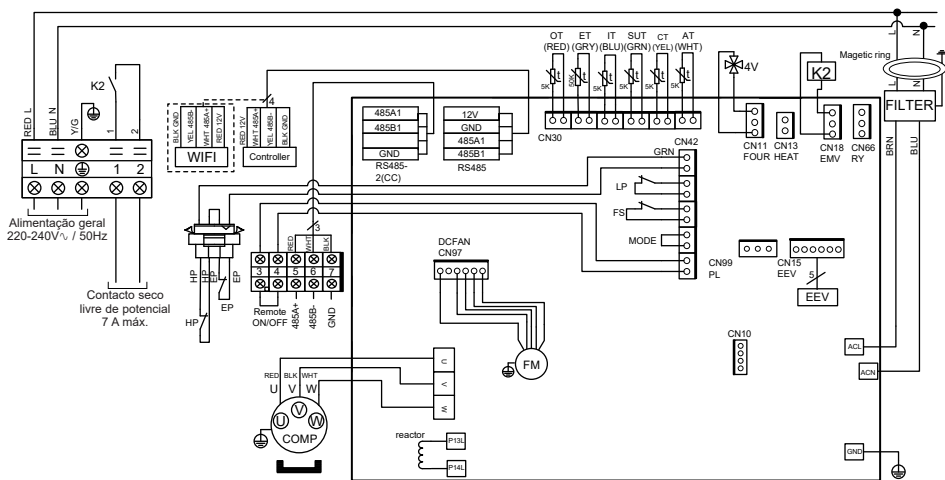

LEGENDA

- | | |
|--|--|
| AT : Sonda de temperatura do ar | LP : Pressóstato baixa pressão |
| COMP : Compressor | OT : Sonda de temperatura saída de água |
| CT : Sonda temperatura evaporador | SUT : Sonda de temperatura de aspiração |
| EEV : Regulador electrónico | 4V : Válvula de 4 vias |
| FM : Motor ventilador | K2 : Contacto seco livre de potencial 7 A máx |
| FS : Detector presença de água | ET : Sonda de temperatura de descarga |
| HP : Pressóstato alta pressão | IT : Sonda de temperatura entrada de água |
| | OPÇÃO : Opção |

6. ANEXOS (continuação)

6.2 Ligações prioridade aquecimento bomba monofásica

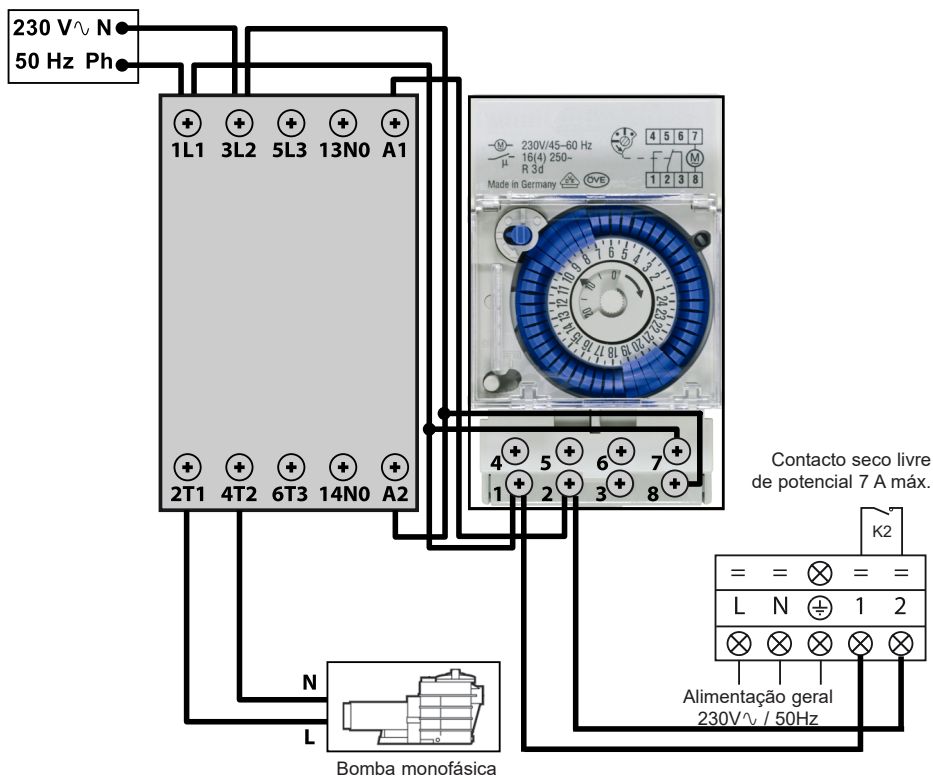

Os terminais 1 e 2 emitem um contacto seco livre de potencial, sem polaridade de 230 V~/50 Hz.

Cablar os terminais 1 e 2 respeitando a cablagem indicada acima, a fim de controlar o funcionamento da bomba de filtração por ciclo de 2 minutos todas as horas se a temperatura da bacia for inferior ao ponto recomendado.



Nunca conecte a alimentação da bomba de filtração directamente sobre os terminais 1 e 2.

6. ANEXOS (continuação)

6.3 Vistas explodidas e peças sobressalentes

HP5081DT3LV / HP5111DT3LV / HP5151DT3LV

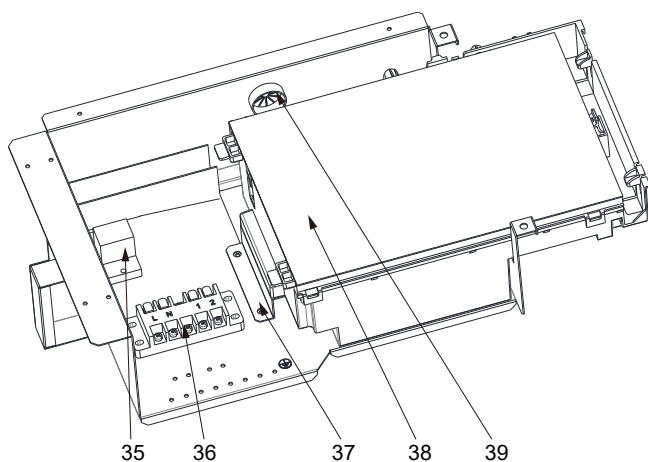
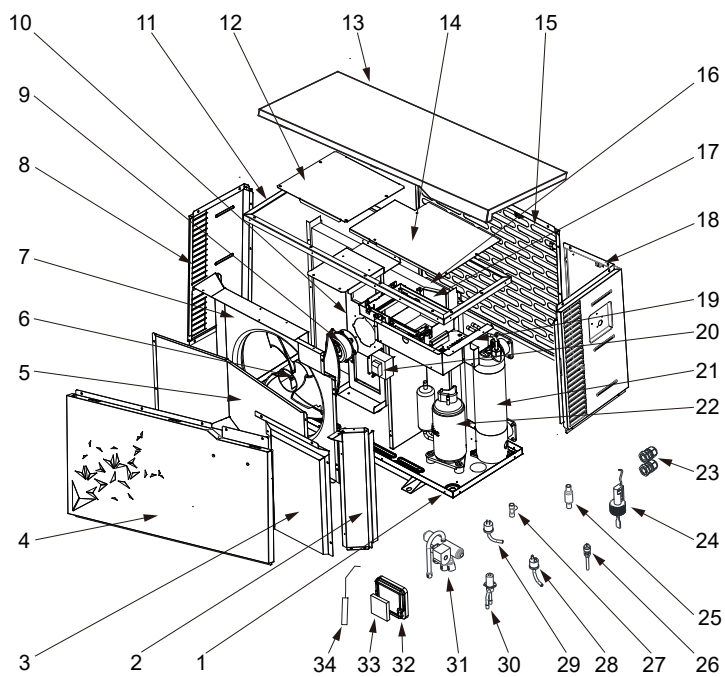

6. ANEXOS (continuação)

Rep	Designação	Ref.	HP5081DT3LV	HP5111DT3LV	HP5151DT3LV
1	/	/	/	/	/
2	/	/	/	/	/
3	/	/	/	/	/
4	Painel dianteiro	HWX80715842	✓	✓	n/a
		HWX80715857	n/a	n/a	✓
5	/	/	/	/	/
6	Hélice ventilador	HWX301030000006	✓	✓	n/a
		HWX20000270004	n/a	n/a	✓
7	/	/	/	/	/
8	Painel esquerdo	HWX80713420	✓	✓	n/a
		HWX80713423	n/a	n/a	✓
9	Motor do ventilador DC	HWX80200018	✓	✓	n/a
		HWX20000330132	n/a	n/a	✓
10	Suporte do motor	HWX80708597	✓	✓	n/a
		HWX80709977	n/a	n/a	✓
11	/	/	/	/	/
12	/	/	/	/	/
13	Painel superior	HWX80708601	✓	✓	n/a
		HWX80709984	n/a	n/a	✓
14	/	/	/	/	/
15	Painel traseiro	HWX80710829	✓	✓	n/a
		HWX80710966	n/a	n/a	✓
16	Evaporador de alheta	HWX80600849	✓	n/a	n/a
		HWX80600781	n/a	✓	n/a
		HWX80600835	n/a	n/a	✓
17	/	/	/	/	/
18	Painel direito	HWX80713421	✓	✓	n/a
		HWX80713424	n/a	n/a	✓
19	/	/	/	/	/
20	Reatância	HWX82500020	✓	✓	n/a
		HWX82500021	n/a	n/a	✓
21	Condensador Titânio/PVC	HWX80600939	✓	n/a	n/a
		HWX80600940	n/a	✓	✓
		HWX80600096	n/a	n/a	✓
22	Compressor	HWX20000110448	✓	✓	n/a
		HWX80100046	n/a	n/a	✓
23	Prensa estopa	HWX20012249	✓	✓	n/a
		HWX20012238	n/a	n/a	✓
24	Detector de caudal de água	HWX83000068	✓	✓	✓
25	Filtro Ø9.7-Ø9.7 (Ø19)	HWX20000140178	✓	✓	n/a
	Filtro Ø9.7-Ø9.7 (Ø28)	HWX20041444	n/a	n/a	✓
26	Medição da pressão 40mm-1/2"	HWX20000140150	✓	✓	✓
27	Conector T Ø9.52-2 x Ø6.35(T) x 1.0	HWX30403000002	✓	✓	n/a
	Conector T Ø6.5-2 x Ø6.5(T) x 0.75	HWX20001460	n/a	n/a	✓
28	Pressóstato de baixa pressão NO 0.30MPa/0.15MPa	HWX20000360157	✓	✓	✓
29	Pressóstato de alta pressão NC 3.2MPa/4.4MPa	HWX20013605	✓	✓	✓
30	Regulador electrónico	HWX81000011	✓	✓	n/a
		HWX81000017	n/a	n/a	✓
31	Válvula de 4 vias	HWX20041437	✓	✓	n/a
		HWX20000140485	n/a	n/a	✓
32	Suporte do Controlador	HWX80901004	✓	✓	✓
33	Controlador LCD Bluetooth	HWX72200312	✓	✓	✓

6. ANEXOS (continuação)

HP5081DT3LV / HP5111DT3LV / HP5151DT3LV

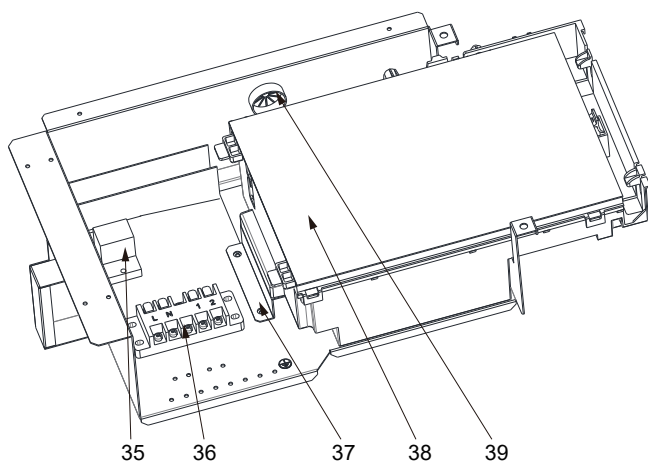
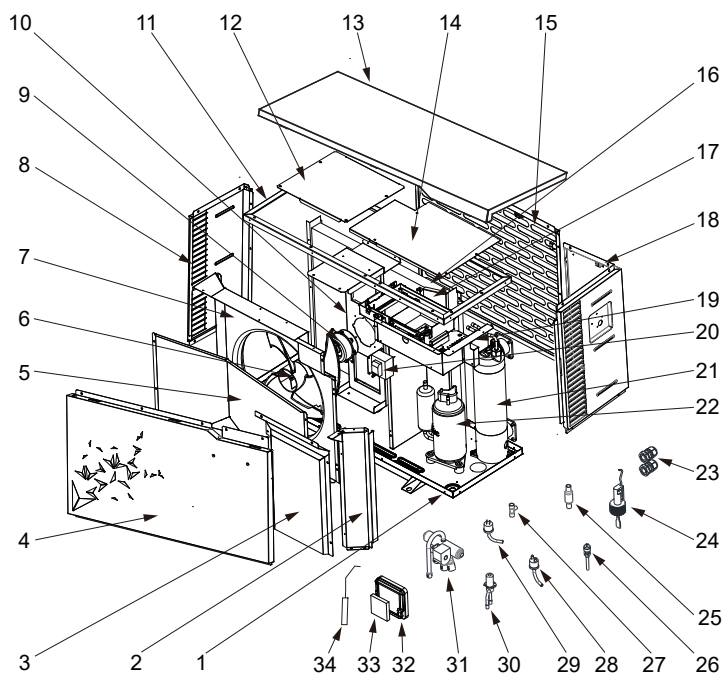

6. ANEXOS (continuação)

Rep	Designação	Ref.	HP5081DT3LV	HP5111DT3LV	HP5151DT3LV
34	Sonda de saída de água 5k-410mm	HWX83000050	✓	✓	✓
	Sonda de entrada de água 5k-850mm	HWX83000052	✓	✓	✓
	Sonda de descarga compressor 50k-660mm	HWX83000026	✓	✓	✓
	Sonda de aspiração compressor 5k-560mm	HWX83000044	✓	✓	n/a
	Sonda de aspiração compressor 5k-760mm	HWX83000053	n/a	n/a	✓
	Sonda descongelação 5k-680mm	HWX83000051	✓	✓	n/a
	Sonda descongelação 5k-1040mm	HWX83000045	n/a	n/a	✓
	Sonda de temperatura 5k-350mm	HWX83000049	✓	✓	✓
35	Relés K2	HWX20000360297	✓	✓	✓
36	Terminal L-N-GND -5 ligações 4mm ²	HWX40003901	✓	✓	✓
37	/	/	/	/	/
38	Placa eletrónica Driver	HWX72200168SL08	✓	n/a	n/a
		HWX72200168SL11	n/a	✓	n/a
		HWX72200168SL15	n/a	n/a	✓
39	/	/	/	/	/

6. ANEXOS (continuação)



6.4 Guia de resolução de problemas

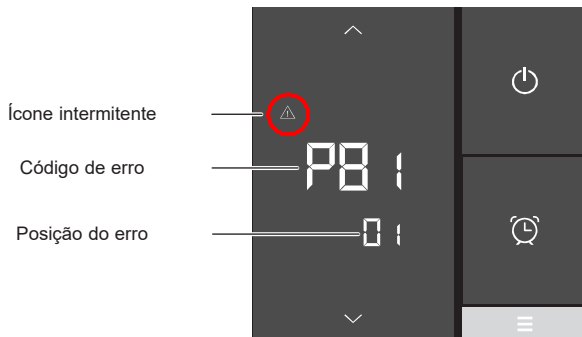

Algumas operações devem ser realizadas por um técnico qualificado.

Em caso de falha, as indicações seguintes são exibidas no ecrã:



Em caso de erro, pressionar  ou  para percorrer os códigos de erro. Consultar a tabela seguinte.



Após a resolução do problema, o erro é apagado automaticamente e o triângulo desaparece.

6. ANEXOS (continuação)

Avaria	Códigos de erro	Descrição	Solução
Problema sonda de entrada de água (IT)	P01	O sensor está aberto ou em curto circuito	Verificar a ligação no conector da extensão ou substituir o sensor
Falha na sonda de saída de água (OT)	P02		
Falha na sonda de temperatura exterior (AT)	P04		
Falha no sensor de degelo (CT)	P05		
Falha na sonda de aspiração compressor (SUT)	P07		
Falha na sonda de descarga Compressor (ET)	P08		
Falha de alta pressão	E01	O sensor está aberto ou em curto circuito	Verificar a ligação no conector da extensão ou substituir o sensor
			Verificar o caudal de água
			Verificar o detector de caudal de água
			Verificar a abertura das válvulas
			Verificar o by-pass
			Verificar a sujidade do evaporador
			Temperatura da água muito elevada
			Problema de gás não condensável após manutenção, fechar e retirar o vácuo do circuito frigorífico
Carga de fluido muito elevada, retirar o fluido com uma garrafa			
Falha de baixa pressão	E02	O sensor está aberto ou em curto circuito	Verificar a ligação no conector da extensão ou substituir o sensor
			Fuga grave de fluido de refrigeração, procurar uma fuga com o detector
			Fluxo de ar muito fraco, verificar a velocidade de rotação do ventilador
			Verificar a sujidade do evaporador, limpar a superfície

6. ANEXOS (continuação)

Avaria	Códigos de erro	Descrição	Solução
Falha no detetor de débito	E03	O sensor está aberto ou em curto circuito	Verificar a ligação CN29/OVT na placa ou substituir o sensor
			Falta de água, verificar o funcionamento da bomba de filtração
			Verificar a abertura das válvulas de paragem
			Verificar a configuração do by-pass
Diferença de temperatura entrada/saída > 13 °C	E06	Aplicável apenas no modo Frio	Falta de água, verificar o funcionamento da bomba de filtração
			Verificar a abertura das válvulas de paragem
			Verificar a configuração do by-pass
Proteção antigeadada	E07	Temperatura de saída da água < 4°C	Parar a bomba de calor, esvaziar o condensador, risco de congelamento
Problema de comunicação	E08	Ausência de comunicação entre a placa eletrónica e a interface do utilizador	Verificar ligações e cablagem - ver diagrama de cablagem
Proteção antigeadada de nível 1	E19	2°C < Temperatura da água < 4°C E Temperatura do ar < 0°C	Interromper o funcionamento da bomba de calor, esvaziar o condensador para evitar a geada. Por padrão, a bomba de calor inicia a bomba de filtração para evitar a entrada de geada
Proteção antigeadada de nível 2	E29	Temperatura da água < 2°C e Temperatura do ar < 0°C	Interromper o funcionamento da bomba de calor, esvaziar o condensador para evitar a geada. Por padrão, a bomba de calor inicia a bomba de filtração e a bomba de calor para evitar a entrada de geada.
Falha do motor do ventilador	F03 I	Motor bloqueado ou falha na ligação	Verificar a ausência de bloqueio da rotação; verificar a ligação CN97/DCFAN; substituir o motor
Falha do motor do ventilador	F05 I	Falha de conexão	Verificar a ligação DCFAN/CN97; substituir motor
Temperatura exterior excessivamente baixa	EP	Limite de funcionamento atingido	Desligar a bomba de calor
A bomba de calor não arranca	- - - OFF	Contacto (5-6) Remoto Ligar/Desligar Aberto	Fechar o contacto (5-6) Remoto Ligar/Desligar à distância (ver diagrama elétrico)

6. ANEXOS (continuação)

6.5 Garantia

CONDIÇÕES DE GARANTIA

Todos os produtos HAYWARD são garantidos contra todos os defeitos de fabrico ou de matéria-prima durante um período de dois anos a contar da data de aquisição. Qualquer reclamação de garantia deverá ser acompanhada de uma prova de compra contendo a data. Recomendamos, assim, que conserve a sua factura.

A garantia HAYWARD é limitada à reparação ou substituição, por opção da HAYWARD, dos produtos defeituosos desde que tenham sido submetidos a uma utilização normal, em conformidade com as prescrições mencionadas no respectivo manual de utilização, que o produto não tenha sido modificado de nenhuma forma e tenha sido utilizado unicamente com componentes e peças da HAYWARD. Os danos devidos ao gelo e aos ataques de agentes químicos não são garantidos. Todas as outras despesas (transporte, mão-de-obra...) estão excluídas da garantia.

A HAYWARD não poderá ser considerada responsável por qualquer dano directo ou indirecto proveniente da instalação, da ligação ou do funcionamento incorrecto do produto.

Para fazer aplicar uma garantia ou solicitar a reparação ou substituição de um artigo, dirija-se ao seu revendedor. Não será aceite qualquer devolução de material à nossa fábrica sem o nosso acordo prévio por escrito. As peças de desgaste não se encontram cobertas pela garantia.

Página deixada em branco intencionalmente



HAYWARD®

S.Line Pro *Fi*

HEIZPUMPENANLAGE FÜR EIN SCHWIMMBECKEN



Einbau- & Anleitungshandbuch

INHALTSVERZEICHNIS

1. VORWORT	1
2. TECHNISCHE EIGENSCHAFTEN	4
2.1 Technische Daten der Wärmepumpe	4
2.2 Betriebsbereich	5
2.3 Maße	6
3. INSTALLATION UND ANSCHLUSS	7
3.1 Schematische Darstellung	7
3.2 Heizpumpenanlage	7
3.3 Hydraulischer Anschluss	8
3.4 Elektrischer Anschluss	9
3.5 Erste Inbetriebnahme	10
4. BENUTZEROBERFLÄCHE	12
4.1 Allgemeine Darstellung	12
4.2 Einstellung des Wasserdurchsatzes	14
4.3 Einstellung der Uhrzeit	15
4.4 Einstellung der Start-/Stopp-Timer	15
4.5 Einstellung der Timer-Funktion für den SILENCE Modus	17
4.6 Bluetooth-Pairing - Fernsteuerung	18
4.7 Auswahl der Betriebsart	19
4.8 Einstellung und Anzeige des Sollwerts	20
4.9 Sperren und Freigeben des Touchscreens	21
5. WARTUNG UND WINTERZEIT	22
5.1 Wartung	22
5.2 Winterzeit	22
6. ANHANG	23
6.1 Stromtafel	23
6.2 Vorrangige Heizanschlüsse einphasige Pumpe	25
6.3 Explosionszeichnungen und Einzelteile	26
6.4 Anleitung zur Problembehandlung	30
6.5 Garantie	33

Aufmerksam lesen und für einen späteren Gebrauch aufzubewahren.

Dieses Dokument ist dem Eigentümer des Schwimmbeckens zu übergeben und muss von diesem an einem sicheren Ort aufbewahrt werden.

1. VORWORT

Für den Erwerb dieser Hayward Schwimmbadwärmepumpe danken wir Ihnen.

Die S.LINE PRO Wärmepumpe wurde gemäß strengen Fertigungsnormen konzipiert, um den geforderten Höchstqualitätsniveau aus zu genügen.

Durch die Steuerlogik S.LINE PRO erreichte Anpassung von Leistung, Stromverbrauch und Geräuschpegel an den Heizbedarf Ihres Schwimmbades werden Ihnen die Hayward Wärmepumpen außergewöhnliche Leistungen während Ihrer gesamten Badesaison bieten.



Vor Benutzung des Geräts lesen Sie dieses Handbuch aufmerksam durch.

Die S.LINE PRO Wärmepumpen sind ausschließlich zum Heizen vom Schwimmbadwasser ausgelegt, verwenden Sie diese Geräte nicht für andere Zwecke.

Dieses Handbuch enthält alle benötigten Informationen hinsichtlich Installation, Behebung von Funktionsstörungen und Wartung.

Lesen Sie dieses Handbuch aufmerksam durch, bevor Sie das Gerät öffnen oder Wartungsarbeiten am Gerät durchführen. Der Produkthersteller haftet in keinem Fall für die Verletzung eines Benutzers oder die Beschädigung des Geräts, die aus Fehlern bei der Installation, der Pannenbehebung bzw. aus einer nicht erforderlichen Wartung ergeben. Die in diesem Handbuch enthaltenen Anweisungen müssen jederzeit unbedingt beachtet werden.

Jede nicht beachtetete Empfehlung führt zum Verlust der Garantie.

1. VORWORT (Fortsetzung)



Sicherheitsanweisungen



Dieses Gerät enthält R32.

Verwenden Sie niemals ein anderes Kältemittel als R32. Jeder andere gasförmiger Körper, der mit dem R32 gemischt wird, kann unnormal hohe Druckwerte verursachen, die eine Panne oder einen Rohrbruch und Personenverletzungen verursachen können.

VVerwenden Sie bei Reparatur- oder Wartungsarbeiten Kupferrohre, die der Norm EN 12375-1 (Mai 2020) und der europäischen Druckgeräterichtlinie 97/23 / EG entsprechen.

Da die Wärmepumpe unter Druck steht, bohren Sie niemals die Rohrleitungen und versuchen Sie auch nicht diese zu löten. Es besteht Explosionsgefahr.

Setzen Sie niemals das Gerät Flammen, Funken oder anderen Entzündungsquellen aus. Das Gerät könnte explodieren und schwere oder sogar tödliche Verletzungen verursachen.



Die Wärmepumpe ist ausschließlich für eine Installation außerhalb von Gebäuden vorgesehen.

- Zur Lagerung muss die Wärmepumpe in einem gut belüfteten Raum mit einer größeren Bodenfläche als durch folgender Formel errechnete A_{\min} (m²) gelagert werden: $A_{\min} = (M / (2.5 \times 0.22759 \times h_0))^2$
M ist die Kältemittelfüllung im Gerät in und h₀ ist die Lagerungshöhe. Bei Lagerung auf dem Boden h₀ = 0,6 m.
- Das Gerät muss durch qualifiziertes Personal installiert werden.
- Installieren Sie die Pumpe nicht auf einem Träger, der die Vibrationen des Geräts verstärken könnte.
- Prüfen Sie, dass der für das Gerät vorgesehene Träger für das Gerätgewicht korrekt dimensioniert ist.
- Installieren Sie die Pumpe nicht in einem Ort, der ihren Schallpegel verstärken könnte oder in einem Ort, in welchem das Gerätegeräusch die Nachbarschaft stören könnte.
- Alle elektrischen Anschlüsse müssen von einem qualifizierten Fachelektriker und gemäß den im Installationsland geltenden Normen ausgeführt werden – siehe § 3.4.

1. VORWORT (Fortsetzung)

- Vor jeder Elektroarbeit trennen Sie die Hauptstromversorgung und schalten Sie den Trennschalter ab. Jede Versäumnis kann zum Stromschlag führen.
- Prüfen Sie vor der Installation, dass das Erdkabel nicht geschnitten oder getrennt ist.
- Schließen und spannen Sie das Stromanschlusskabel korrekt an. Ein fehlerhafter Anschluss kann zur Beschädigung von Elektroteile führen.
- Falls die Wärmepumpe Wasser bzw. einer feuchten Umgebung ausgesetzt wird, kann daraus einen Stromschlag resultieren. Seien Sie sehr aufmerksam.
- Falls Sie irgendwelchen Fehler bzw. unnormale Situation entdecken, installieren Sie nicht die Wärmepumpe und setzen Sie sich sofort mit Ihrem Händler in Verbindung.
- Die Wartung und diversen Arbeiten müssen mit der in diesem Handbuch angegebenen Häufigkeit und zu den empfohlenen Zeitpunkten ausgeführt werden.
- Reparaturarbeiten müssen von qualifiziertem Personal ausgeführt werden.
- Verwenden Sie nur Originalersatzteile.
- Verwenden Sie niemals ein anderes als das in diesem Handbuch empfohlene Reinigungsverfahren.

Wichtige Informationen über das verwendete Kältemittel

Dieses Produkt enthält fluorierte Treibhausgase gemäß dem Kyoto-Protokoll. Setzen Sie diese Gase nicht in die Atmosphäre aus.

Kältemitteltyp: R32

GWP Wert (1): 675, Wert basiert auf dem 4. IPCC-Bericht.

Die auf Grundlage der Vorschrift F Gas 517/2014 Kältemittelmenge ist auf dem Typenschild des Geräts angegeben.

Gemäß europäischem oder lokalem Recht können regelmäßige Kältemittel-Lecktests erforderlich sein. Für weitere Informationen setzen Sie sich mit Ihrem Händler in Verbindung.

(1) Globaler Erwärmungsfaktor

2. TECHNISCHE EIGENSCHAFTEN

2.1 Technische Daten der Wärmepumpe

Modelle	S.LINE PRO	HP5081DT3LV	HP5111DT3LV	HP5151DT3LV
Versorgungsspannung	V	220V-240V ~ / 1ph / 50Hz		
Kältemittel	/	R32		
Ladung	kg	0,45	0,50	0,65
Gewicht in t CO ₂ -Äquivalent	/	0,30	0,34	0,44
Lecktest-Häufigkeit	/	Nicht vorgeschrieben aber jährlich empfohlen		
Wärmeleistung Min--Max ^(a)	kW	2,83 -- 8,16	1,95 -- 10,90	5,27 -- 15,66
Elektrische Leistungsaufnahme Min--Max ^(a)	kW	0,212 -- 1,19	0,150 -- 1,92	0,457 -- 2,80
Nennstrom im Betrieb Min--Max ^(a)	A	1,41 -- 5,20	1,05 -- 8,49	2,04 -- 12,28
COP Max--Min ^(a)	/	13,30 -- 6,81	12,92 -- 5,67	11,53 -- 5,59
Wärmeleistung Min--Max ^(b)	kW	1,77 -- 5,91	1,86 -- 8,40	3,81 -- 11,67
Elektrische Leistungsaufnahme Min--Max ^(b)	kW	0,31 -- 1,28	0,30 -- 1,83	0,588 -- 2,71
COP Max--Min ^(b)	/	5,70 -- 4,62	6,20 -- 4,59	6,48 -- 4,31
Maximaler Betriebsstrom (MBS)	A	6,50	10,30	14
Sicherungswert	gG	10	12	16
Schutzschalter Typ C	C	10	12	16
Anlaufstrom	A	< MBS		
Hydraulikanschluss	mm	50 mm		
Nenn-Wasserdurchsatz ^(a)	m ³ /h	3,50	4,60	6,70
Max. wasserseitiger Druckverlust	kPa	8	5	10
Kompressor	/	DC Inverter Panasonic		DC Inverter Mitsubishi
Typ	/	DC Inverter MITSUBISHI ELECTRIC		Zweistufiger Schraubenkompressor
Anzahl	/	1		
Wicklungswiderstand bei 20°C	Ohm	1.208		0.95
Gebälse	/	Axial		
Anzahl	/	1		
Durchmesser	mm	1,91 +/- 5%		0,95 +/- 5%
Schaufelanzahl	/	3		
Motor	/	DC Inverter		
Anzahl	/	1		
Drehzahl	U/Min.	500 -- 800	500 -- 900	500 -- 750
Drehzahl im Ruhemodus	U/Min.	500	500	500
Schalldruckpegel in 1 m Abstand	dB(A)	45,1	48,6	54,1
Schalldruckpegel in 10 m Abstand	dB(A)	27,9	31,6	36,9
Nettoabmessungen des Geräts (L-B-H)	mm	1011 / 430 / 622		1025 / 480 / 768
Gewicht	kg	61	61	87



(a) Trockene Luft 27°C - Relative Feuchte 78% - Wassereinslasstemperatur 26°C.

(b) Trockene Luft 15°C - Relative Feuchte 71% - Wassereinslasstemperatur 26°C

2. TECHNISCHE EIGENSCHAFTEN (Fortsetzung)

2.2 Betriebsbereich

Benutzen Sie die Heizpumpenanlage innerhalb der folgenden Temperatur- und Luftfeuchtigkeitsbereichen, um ein sicheres und effizientes Funktionieren zu garantieren.

	Modus Erwärmen 	Modus Abkühlen 
Außentemperatur	-7°C – +35°C	+7°C – +43°C
Wassertemperatur	+12°C – +32°C	+8°C – +40°C
relative Luftfeuchtigkeit	< 80%	< 80%
Einstellbereich des Sollwerts	+15°C – +32°C	+8°C – +32°C



Wenn Temperatur oder Luftfeuchtigkeit nicht diesen Bedingungen entsprechen, können Sicherheitsmaßnahmen ausgelöst werden. Dann arbeitet die Heizpumpenanlage nicht mehr.



Die Höchsttemperatur für die Beheizung beträgt 32 °C, um eine Beschädigung der Verkleidung zu vermeiden. Hayward übernimmt keinerlei Verantwortung bei einer Verwendung über +32 °C.

2. TECHNISCHE EIGENSCHAFTEN (Fortsetzung)

2.3 Maße

Modelle:

HP5081DT3LV / HP5111DT3LV / HP5151DT3LV

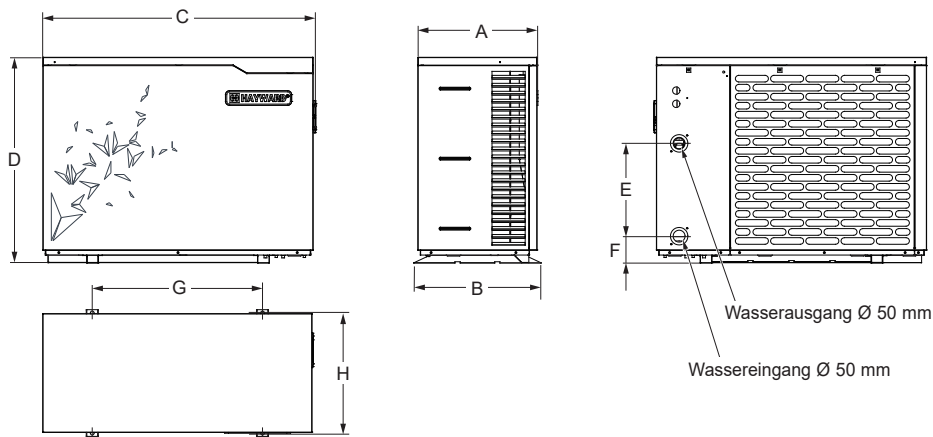

Einheit : mm

Markierung \ Modell	HP5081DT3LV / HP5111DT3LV	HP5151DT3LV
A	393	453
B	430	480
C	1011	1030
D	621,5	776
E	350	350
F	97,5	102
G	625	645
H	406	456

3. INSTALLATION UND ANSCHLUSS

3.1 Schematische Darstellung

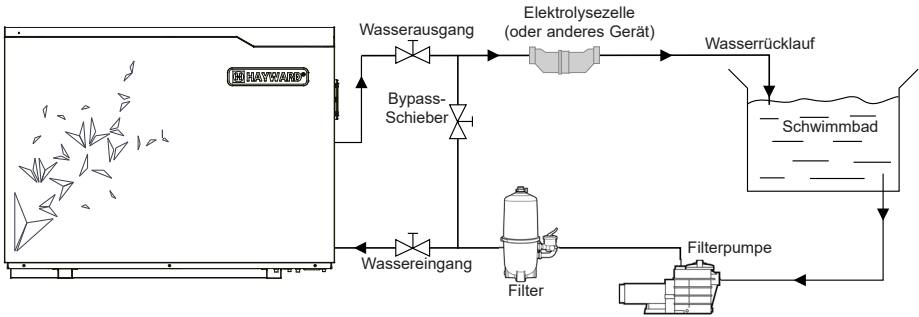

Anmerkung: Die Heizpumpenanlage verfügt über keinerlei Ausstattungs- oder Filtergerät. Die auf der Darstellung gezeigten Elemente werden vom Installateur bereitgestellt.

3.2 Heizpumpenanlage



Stellen Sie die Heizpumpenanlage im Außenraum und außerhalb vollständig geschlossener technischer Orte auf.

Geschützt aufgestellt muss der vorgeschriebene Mindestabstand wie unten genannt eingehalten werden, um die Gefahr einer Luftrückführung oder einer Minderung der effektiven Betriebsleistung der Heizpumpenanlage zu vermeiden.

Einheit : mm

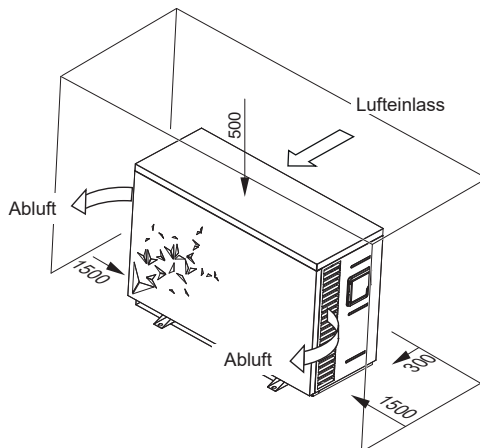

3. INSTALLATION UND ANSCHLÜSSE (Fortsetzung)



Installieren Sie vorzugsweise die Heizpumpenanlage auf einer separaten Betonbodenplatte oder auf einer festen Bestuhlung, die für diesen Zweck bestimmt ist und stellen Sie die Heizpumpenanlage auf die mitgelieferten Silentblöcke (Verschraubung und Unterlegscheiben nicht mitgeliefert).

Maximale Entfernung zwischen Heizpumpenanlage und Schwimmbecken 15 Meter.

Gesamtlänge (hin und zurück) der hydraulischen Leitungen 30 Meter.

Isolieren Sie sowohl die sichtbaren als auch die verdeckten hydraulischen Leitungen.

Die Wärmepumpe ist mit einem Mindestabstand vom Becken gemäß NF C 15-100 (d. h. für Frankreich 3,5 m entfernt von der Wasseroberfläche) oder gemäß den in den jeweiligen Ländern geltenden Installationsstandards zu installieren.

Die Wärmepumpe nicht in der Nähe einer Wärmequelle installieren.

Bei einer Installation in schneereichen Gebieten wird eine Abdeckung der Maschine empfohlen, um eine Schneeanhäufung auf dem Verdampfer zu verhindern.

3.3 Hydraulischer Anschluss

Die Heizpumpenanlage wird mit zwei Verbindungsstücken mit einem Durchmesser von 50 mm geliefert. Verwenden Sie PVC-Rohre mit 50 mm Durchmesser für das hydraulische Leitungsnetz. Schließen Sie die den Wassereingang der Heizpumpenanlage an die Leitung der Filtergruppe an. Schließen Sie dann den Wasserausgang der Heizpumpenanlage an die Wasserleitung des Beckens an (s. Darstellung weiter unten).

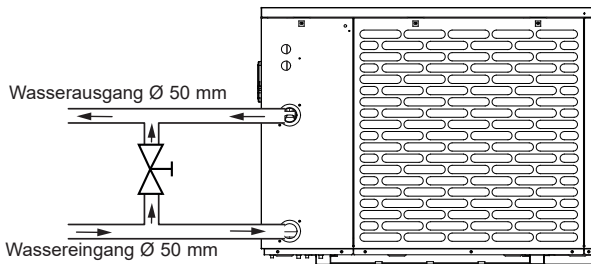

Installieren Sie einen Schieber, den so genannten "By-pass", zwischen den Eingang und den Ausgang der Heizpumpenanlage.



Wird ein automatischer Verteiler oder ein Elektrolyseur verwendet, muss dieser unbedingt nach der Heizpumpenanlage eingebaut werden, um so den Titan-Kondensator gegen eine zu hohe Konzentration chemischer Produkte zu schützen.



Achten Sie darauf, den By-pass-Schieber und die Verbindungsstücke am Ein- und Auslass der Anlage einzubauen, um den problemlosen Ablass der Anlage während der Wintermonate und einen einfacheren Zugang oder einen Abbau bei Wartungsarbeiten zu erleichtern.

3. INSTALLATION UND ANSCHLÜSSE (Fortsetzung)

3.4 Elektrischer Anschluss



Die Elektroinstallation und die Verkabelung dieses Gerätes müssen den geltenden Installationsvorschriften vor Ort entsprechen.

F	NF C15-100	GB	BS7671:1992
D	DIN VDE 0100-702	EW	EVHS-HD 384-7-702
A	ÖVE 8001-4-702	H	MSZ 2364-702/1994/MSZ 10-553 1/1990
E	UNE 20460-7-702 1993, RECBT ITC-BT-31 2002	M	MSA HD 384-7-702.S2
IRL	Wiring Rules (Richtlinien elektrischer Leitungen, Anm. d. Übers.) + IS HD 384-7-702	PL	PN-IEC 60364-7-702:1999
I	CEI 64-8/7	CZ	CSN 33 2000 7-702
LUX	384-7.702 S2	SK	STN 33 2000-7-702
NL	NEN 1010-7-702	SLO	SIST HD 384-7-702.S2
P	RSIUEE	TR	TS IEC 60364-7-702



Prüfen Sie, ob die verfügbare Stromversorgung und die Netzfrequenz den den erforderlichem Betriebsstrom entsprechen. Dabei müssen der jeweilige Standort des Gerätes und der erforderliche Strombedarf aller anderen, am gleichen Schaltkreis angeschlossener Geräte berücksichtigt werden.

HP5081DT3LV / HP5111DT3LV / HP5151DT3LV
230V \sim +/- 10 % 50 Hz 1 Phase

Beachten Sie die schematische Darstellung der Verkabelung im Anhang. Es gibt drei Anschlüsse für die Stromversorgung und zwei für die Steuerung der Filterpumpe (Nachlaufsteuerung).

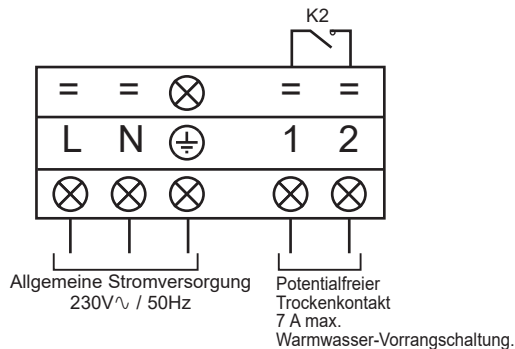

3. INSTALLATION UND ANSCHLUSS (Fortsetzung)



Die Leitung der Stromversorgung muss ordnungsgemäß mit einer Gerätesicherung vom Typ Motorversorgung (gG) oder einem Hauptschalter C sowie einem Differentialschalter 30mA ausgestattet sein (siehe nachfolgende Tafel).

Modelle		HP5091DT3H	HP5111DT3H	HP5151DT3H
Netzteil	V/Ph/ Hz	230V~ 50Hz	230V~ 50Hz	230V~ 50Hz
Sicherungsdurchmesser Typ gG	A	10 gG	12 gG	16 gG
Leistungsschalter Kurve C	A	10 C	12 C	16 C
Leitungsquerschnitt	mm ²	3G 2.5	3G 2.5	3G 2.5



Ein Netzkabel vom Typ RO 2V / R 2V oder vergleichbar.



Die Leitungsquerschnitte werden für maximal 25 m Länge angegeben. Sie müssen gleichwohl überprüft und auf die Installationsbedingungen angepasst werden.



Achten Sie stets darauf, dass die Hauptstromversorgung abgeschaltet ist, bevor Sie den elektrischen Steuerkasten öffnen.

3.5 Erste Inbetriebnahme

Verfahren zur Inbetriebnahme - Nachdem Sie die Installation beendet haben, gehen Sie wie folgt vor:

- 1) Drehen Sie die Ventilatoren von Hand, um zu überprüfen, dass sie sich frei von Hand bewegen lassen und dass der Propeller korrekt auf der Antriebswelle befestigt ist.
- 2) Vergewissern Sie sich, dass die Einheit korrekt an die Hauptstromversorgung angeschlossen ist (siehe Schaltplan im Anhang).
- 3) Starten Sie die Filterpumpe.
- 4) Vergewissern Sie sich, dass alle Wasserein- und auslässe offen sind und dass das Wasser in die Anlage, bevor es erwärmt oder abgekühlt wird.
- 5) Vergewissern Sie sich, dass das Ablassrohr für das Kondensat ordnungsgemäß befestigt und frei von Blockaden ist.
- 6) Aktivieren Sie die Stromversorgung für die Anlage und drücken Sie dann den Start/Stop-Knopf  auf der Bedientafel.

3. INSTALLATION UND ANSCHLUSS (Fortsetzung)

- 7) Prüfen Sie, dass die Alarm- bzw. Sperrsymbole nicht aufleuchten. Siehe gegebenenfalls die Anleitung zur Pannenbehebung (siehe § 6.4).
- 8) Arretieren Sie den Wasserdurchsatz mit dem By-pass-Schieber (s. § 2.1 und 4.2), wie für das jeweilige Modell vorgeschrieben, so dass eine Temperaturdifferenz zwischen Wasserein- und -ausgang von 2°C beibehalten wird.
- 9) Nachdem die Anlage einige Minuten in Betrieb ist, vergewissern Sie sich, dass die Luft, die aus der Anlage ausströmt, sich abgekühlt hat (um 5°C bis 10°C).
- 10) Ist die Anlage in Betrieb, schalten Sie die Filterpumpe ab. Die Anlage sollte sich automatisch abschalten und den Fehlercode E03 anzeigen.
- 11) Lassen sie die Anlage und die Schwimmbadpumpe 24 Stunden am Tag laufen, bis die gewünschte Wassertemperatur im Pool erreicht ist. Sobald das Eingangswasser die gewünschte Temperatur erreicht hat, schaltet sich die Anlage ab. Sie wird sich dann wieder automatisch einschalten (sofern die Schwimmbadpumpe in Betrieb ist), wenn die Temperatur des Schwimmbadwassers um mehr als 0,5°C von der eingestellten Temperatur abweicht.

Wasserdurchsatzregler - Die Anlage ist mit einem Regler für den Wasserdurchsatz ausgestattet, der diese einschaltet, wenn die Pumpe des Schwimmbadfilters in Betrieb ist und der diese ausschaltet, wenn die Filterpumpe außer Betrieb ist. Fehlt Wasser, so erscheint der Alarm-Code E03 auf dem Regler (siehe § 6.4).

Zeitliche Verzögerung - Die Anlage enthält eine zeitliche Verzögerung von 3 Minuten, welche die Komponenten des Steuerschaltkreises schützt und jegliche Instabilität bezüglich eines Neustarts sowie jegliche Störung im Bereich des Kontaktgebers verhindert. Aufgrund dieser zeitlichen Verzögerung startet die Anlage ca. 3 Minuten nach jeder Unterbrechung des Steuerschaltkreises automatisch neu. Selbst eine kurze Stromunterbrechung aktiviert diese zeitliche Verzögerung.

4. BENUTZER OBERFLÄCHE

4.1 Allgemeine Darstellung

Die Wärmepumpe ist mit einem digitalen Touchscreen-Bedienfeld ausgestattet, elektronisch angeschlossen und werksseitig auf Heizmodus voreingestellt.

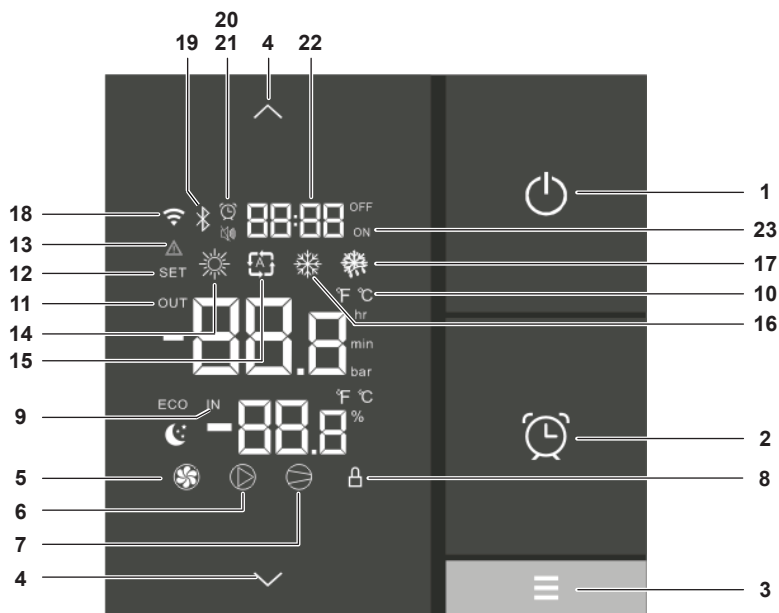

Legende

1		Ein / Aus / Storno
2		Uhrzeit- und Timereinstellung
3		Auswahl der Betriebsart
4		Nach oben / unten scrollen, +°C / -°C
5		Ventilator ON
6		Trockenkontakt OUT2 ON
7		Kompressor ON
8		Touchscreen gesperrt
9		Wassereingang
10		Celsius / Fahrenheit
11		Wasserausgang
12		Erweiterte Einstellungen

13		Systemfehler
14		Modus Heizen
15		Automatikmodus
16		Modus Kühlen
17		Modus Abtauen
18		N/A
19		Bluetooth-Verbindung
20		Timer programmiert
21		Kontrolleuchte Silence Modus / Timer
22		Uhrzeit / Uhrzeit für die Timer
23		Start- und Stoppzeit für Timer programmiert

4. BENUTZEROBERFLÄCHE (Fortsetzung)

OFF-/AUS-Modus

Befindet sich die Wärmepumpe im Stand-by-Modus (OFF-Modus), erscheint im Bedienfeld die Anzeige OFF und das Bedienfeld wechselt nach einer Minute in den Energiesparmodus.

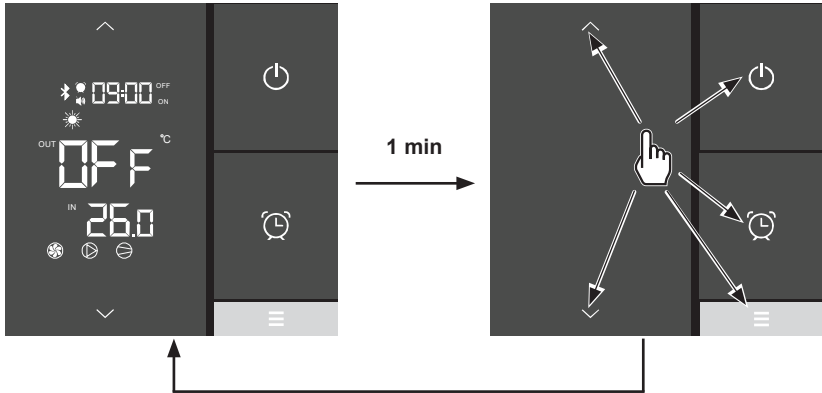

Drücken Sie eine beliebige Taste, um zur vollständigen Anzeige zurückzukehren.

ON-Modus

Befindet sich die Wärmepumpe in Betrieb oder in der Regulierung (ON-Modus), so erscheinen die Temperaturen des eintretenden und des austretenden Wassers im Bedienfeld und das Bedienfeld wechselt nach einer Minute in den Energiesparmodus.

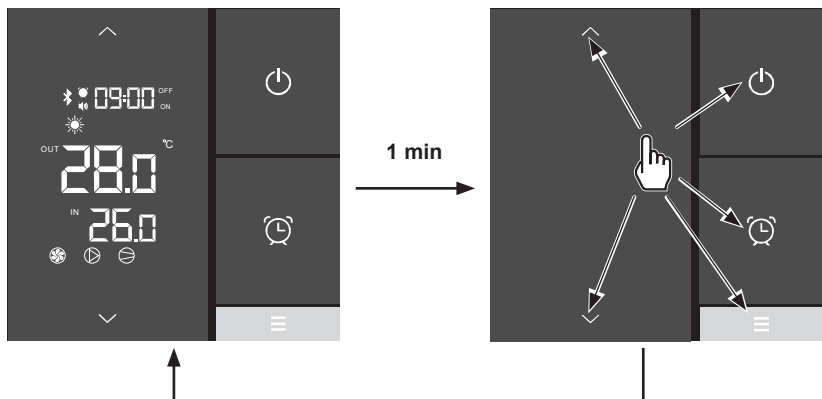

Drücken Sie eine beliebige Taste, um zur vollständigen Anzeige zurückzukehren.

4. INTERFACE UTILISATEUR (suite)

4.2 Einstellung des Wasserdurchsatzes

Stellen Sie den sogenannten By-pass-Schieber bei geöffneten Wassereinlass- und -auslassschiebern so ein, dass ein Unterschied von 2 °C zwischen der Wassereingangs- und der Wasserausgangstemperatur erreicht wird (siehe Schematische Darstellung § 3.1).

Sie können die Einstellung der Eingangs- und Ausgangstemperaturen direkt auf der Bedientafel kontrollieren, indem Sie wie nachfolgend beschrieben vorgehen.

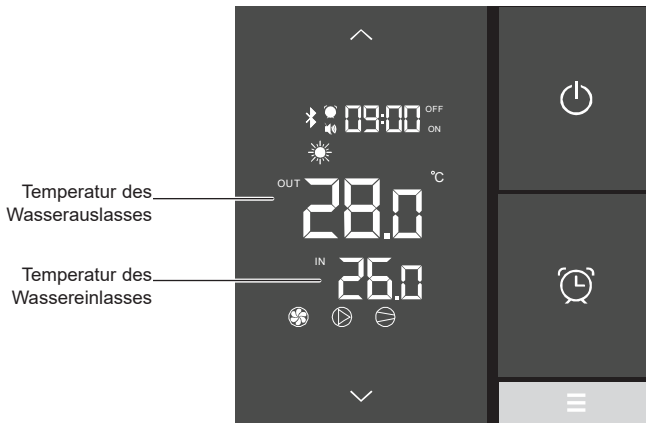

Stellen Sie anschließend den By-pass so ein, dass ein Unterschied von 2°C zwischen der Wassereingangs- und der Wasserausgangstemperatur erreicht wird. Drücken Sie auf , um das Menü zu verlassen.

- Das Öffnen des By-pass-Schiebers führt zu einem geringeren Durchsatz im Tauscher der Wärmepumpe, wodurch sich die Temperaturdifferenz zwischen Wasserein- und -ausgang erhöht.
- Das Schließen des By-pass-Schiebers führt zu einem höheren Durchsatz im Tauscher der Wärmepumpe, wodurch sich die Temperaturdifferenz zwischen Wasserein- und -ausgang verringert.

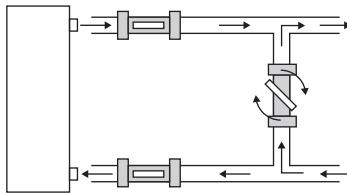









Sie können die Einstellung der Eingangs- und Ausgangstemperatur (1-2) direkt über die App „EyesPool Inverter Connect“ kontrollieren (siehe § 4.6).



4. BENUTZEROBERFLÄCHE (Fortsetzung)

4.3 Einstellung der Uhrzeit

Drücken Sie nach Beendigung der Einstellungen zur Bestätigung auf . Die Einstellungen werden automatisch gespeichert, wenn innerhalb von 5 Sekunden keine Aktion erfolgt.













- Drücken Sie auf , die Uhrzeitanzeige blinkt.
- Drücken Sie auf , die Stundenanzeige blinkt. Stellen Sie die Stunden mit den Tasten  und  ein.
- Drücken Sie auf  und stellen Sie dann die Minuten mit den Tasten  und  ein.
- Drücken Sie zur Bestätigung auf .

4.4 Einstellung der Start-/Stopp-Timer

Die Einstellung dieser Funktion ist erforderlich, wenn Sie Ihre Wärmepumpe auf einen kürzeren Zeitraum einstellen wollen als durch die Filteruhr festgelegt. So können Sie einen verzögerten Start und ein vorzeitiges Abschalten programmieren oder eine Betriebszeit (zum Beispiel nachts) untersagen.

Sie können einen Start-Timer (ON) und einen Stopp-Timer (OFF) programmieren.

Programmierung des Start-Timers (ON)

- Halten Sie die Taste  2 Sekunden lang gedrückt, bis das Symbol  blinkt.
- Drücken Sie auf , die Anzeige  blinkt (.
- Drücken Sie auf , um die Stunden mit den Tasten  und  einzustellen.
- Drücken Sie auf , um die Minuten mit den Tasten  und  einzustellen.
- Drücken Sie zur Bestätigung auf  und dann auf , um zum Hauptbildschirm zurückzukehren.















Die Einstellungen werden automatisch gespeichert, wenn innerhalb von 20 Sekunden keine Aktion erfolgt.

Die Einstellung der Minuten erfolgt in Schritten von jeweils 10 Minuten.

Wenn auf dem Hauptbildschirm unterhalb der Uhrzeitanzeige ON angezeigt wird, ist der Start-Timer (ON) programmiert.

4. BENUTZEROBERFLÄCHE (Fortsetzung)

Programmierung des Stopp-Timers (OFF)







- Halten Sie die Taste  2 Sekunden lang gedrückt, bis das Symbol  blinkt.
- Drücken Sie auf , die Anzeige  blinkt (ON).
- Drücken Sie auf , die Anzeige  blinkt (OFF).
- Drücken Sie auf , um die Stunden mit den Tasten  und  einzustellen.
- Drücken Sie auf , um die Minuten mit den Tasten  und  einzustellen.
- Drücken Sie zur Bestätigung auf  und dann auf , um zum Hauptbildschirm zurückzukehren.

Die Einstellungen werden automatisch gespeichert, wenn innerhalb von 20 Sekunden keine Aktion erfolgt.

Die Einstellung der Minuten erfolgt in Schritten von jeweils 10 Minuten.





Wenn auf dem Hauptbildschirm oberhalb der Uhrzeitanzeige OFF angezeigt wird, ist der Stopp-Timer (OFF) programmiert.

Abfrage der Timer







- Halten Sie die Taste  2 Sekunden lang gedrückt, bis das Symbol  blinkt.
- Drücken Sie auf , die Startzeit  blinkt.
- Drücken Sie auf , die Stoppzeit  blinkt.
- Drücken Sie auf , um zum Hauptbildschirm zurückzukehren.

Das Symbol  wird auf dem Hauptbildschirm angezeigt, wenn ein Start-Timer und/oder ein Stopp-Timer programmiert ist.

Löschen der Start- und Stopp-Timer (ON / OFF)











- Halten Sie die Taste  2 Sekunden lang gedrückt, bis das Symbol  blinkt.
- Drücken Sie 2-mal auf , die Stunden der Startzeit blinken .
- Drücken Sie auf , um den Start-Timer zu löschen .

Drücken Sie nach Beendigung von Schritt 3 auf , um zum Hauptbildschirm zurückzukehren oder um mit Schritt 4 fortzufahren.

- Drücken Sie auf , um die Stoppzeit aufzurufen .
- Drücken Sie auf , die Stunden der Stoppzeit blinken .
- Drücken Sie auf , um den Stopp-Timer zu löschen .
- Drücken Sie auf , um zum Hauptbildschirm zurückzukehren.

4. BENUTZEROBERFLÄCHE (Fortsetzung)

















Löschen des Stopp-Timers (OFF)

- Halten Sie die Taste  2 Sekunden lang gedrückt, bis das Symbol  blinkt.
- Drücken Sie 2-mal auf , die Stunden der Startzeit blinken .
- Drücken Sie auf , um die Stoppzeit aufzurufen .
- Drücken Sie auf , die Stunden der Stoppzeit blinken .
- Drücken Sie auf , um den Stopp-Timer zu löschen .
- Drücken Sie auf , um zum Hauptbildschirm zurückzukehren.











4.5 Einstellung der Timer-Funktion für den SILENCE Modus

Der SILENCE Modus ermöglicht eine äußerst leise Nutzung der Wärmepumpe im Energiesparmodus, wenn der Heizbedarf gering ist (Aufrechterhaltung der Beckentemperatur oder falls ein extrem leiser Betrieb erforderlich ist).

Programmierung des Timers für den SILENCE Modus

- Halten Sie die Taste  2 Sekunden lang gedrückt, bis das Symbol  blinkt.
- Drücken Sie auf , das Symbol  blinkt.
- Drücken Sie auf , die Anzeige  blinkt.
- Drücken Sie auf , um die Startzeit mit den Tasten  und  einzustellen.
- Drücken Sie auf  und dann auf , die Anzeige  blinkt.
- Drücken Sie auf , um die Stoppzeit mit den Tasten  und  einzustellen.
- Drücken Sie zur Bestätigung auf  und dann auf , um zum Hauptbildschirm zurückzukehren.







Löschen des Timers für den SILENCE Modus

- Halten Sie die Taste  2 Sekunden lang gedrückt, bis das Symbol  blinkt.
- Drücken Sie auf , das Symbol  blinkt.
- Drücken Sie auf , die Startzeit  blinkt.
- Drücken Sie auf , nur die Stunden blinken.
- Drücken Sie auf , die Anzeige  blinkt.
- Drücken Sie auf , um zum Hauptbildschirm zurückzukehren.

Durch Löschen des Start-Timers wird gleichzeitig der Stopp-Timer gelöscht. Die Einstellung erfolgt in Schritten von jeweils einer Stunde.

4. BENUTZEROBERFLÄCHE (Fortsetzung)

Abfrage des Timers für den SILENCE Modus

- Halten Sie die Taste  2 Sekunden lang gedrückt, bis das Symbol  blinkt.
- Drücken Sie auf , das Symbol  blinkt.
- Drücken Sie auf , um die Startzeit anzuzeigen.
- Drücken Sie auf , um die Stoppzeit anzuzeigen.
- Drücken Sie auf , um zum Hauptbildschirm zurückzukehren.



Wenn das Symbol  auf dem Hauptbildschirm angezeigt wird, ist ein Start- oder ein Stopp-Timer für den SILENCE Modus programmiert.

4.6 Bluetooth-Pairing - Fernsteuerung

Die Wärmepumpe ist mit der Bluetooth-Funktion ausgestattet.

Über die App „*EyesPool Inverter Connect*“ können Sie Ihr Smartphone als Fernbedienung benutzen und Ihre Wärmepumpe aus einer Distanz von bis zu 10 m im freien Feld steuern.

Um die Funktion  **Bluetooth**™ nutzen zu können:

- ▶ Laden Sie die App „*EyesPool Inverter Connect*“ kostenfrei auf  oder  herunter.
- ▶ Legen Sie in der App ein Konto an.
- ▶ Folgen Sie den Anweisungen in dem Video (siehe Links weiter unten), um Ihr Smartphone mit der Wärmepumpe zu verbinden:
<https://www.hayward.fr/article/tutoriels-hayward/s-line-pro-bluetooth-appairage>



4. BENUTZEROBERFLÄCHE (Fortsetzung)

4.7 Auswahl der Betriebsart

Heizen - Automatik - Kühlen



Wenn die Wärmepumpe durch den Installateur auf Nur Heizbetrieb oder Nur Kühlbetrieb eingestellt wurde, kann die Betriebsart nicht mehr geändert werden.

Drücken Sie die Taste , um die Betriebsart zu wechseln: Heizen - Automatik - Kühlen.

Heizen



Automatik



Kühlen

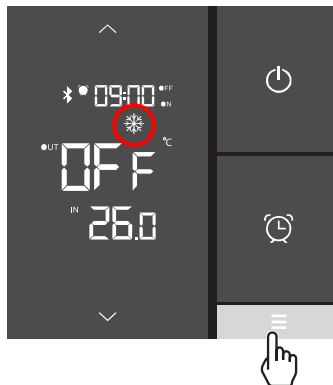

4. BENUTZEROBERFLÄCHE (Fortsetzung)

4.8 Einstellung und Anzeige des Sollwerts

Gewünschte Wassertemperatur

Die Einstellung des Sollwerts kann sowohl im OFF-Modus als auch im ON-Modus mit einer Präzision von 0,5°C vorgenommen werden.

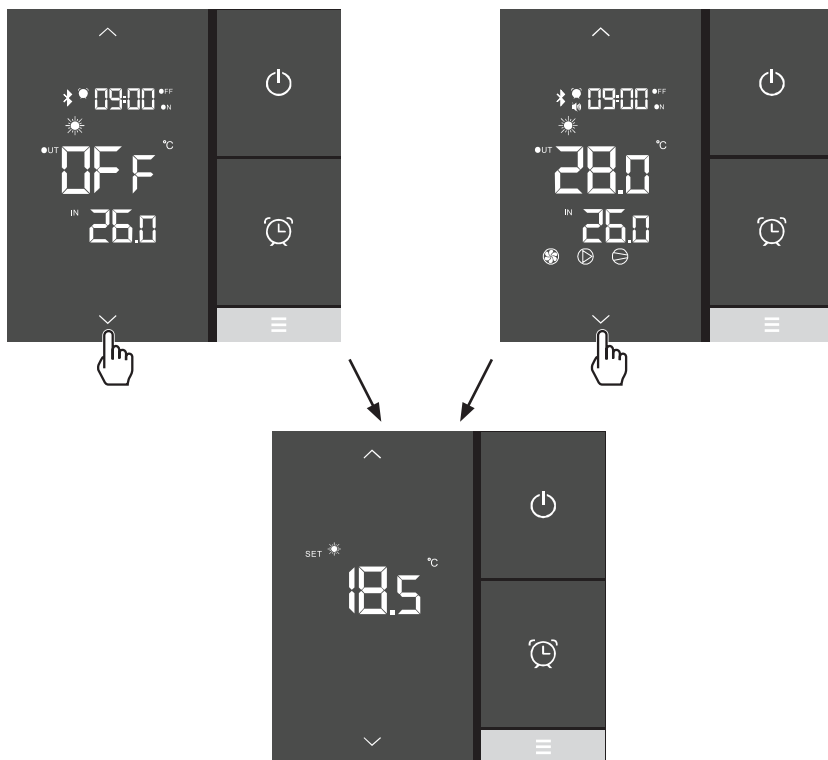

- Drücken Sie auf oder , damit der Sollwert blinkt.
- Drücken Sie auf oder , um den gewünschten Sollwert einzustellen.
- Drücken Sie auf , um die Eingabe zu bestätigen oder auf , um die Eingabe zu löschen.

Die Einstellung wird automatisch gespeichert, wenn innerhalb von 5 Sekunden keine Aktion erfolgt.







Eine Höchsttemperatur von 30°C wird empfohlen, um eine Beschädigung der Verkleidung zu vermeiden.

4. BENUTZEROBERFLÄCHE (Fortsetzung)

4.9 Sperren und Freigeben des Touchscreens

Das Sperren und Freigeben des Touchscreens kann sowohl im ON-Modus als auch im OFF-Modus vorgenommen werden.

- Halten Sie die Taste  5 Sekunden lang gedrückt, bis das Symbol  erscheint.
- Um den Touchscreen zu entsperren, halten Sie die Taste  gedrückt, bis das Symbol  verschwindet.

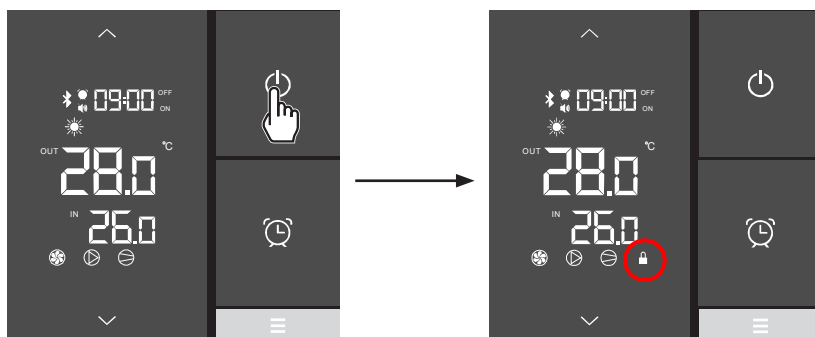

5. WARTUNG UND WINTERZEIT

5.1 Wartung

Diese Maßregeln zur Wartung müssen ein Mal pro Jahr durchgeführt werden, um die Langlebigkeit und gute Funktionsweise der Heizpumpenanlage zu garantieren.

- Reinigen Sie den Evaporator mit Hilfe einer flexiblen Bürste, einem Luft- oder einem Wasserstrahl (**Achtung: Verwenden Sie niemals einen Hochdruckreiniger**).
- Kontrollieren Sie den korrekten Abfluss des Kondensats.
- Kontrollieren Sie die hydraulischen und elektrischen Anschlüsse.
- Kontrollieren Sie die hydraulische Dichtigkeit des Kondensator.
- Die Dichtheit des Kältekreislaufs mithilfe eines Leckdetektors **durch eine autorisierte Fachkraft** prüfen lassen.



Vor allen Wartungsmaßnahmen muss die Heizpumpenanlage von jeglicher Stromversorgung getrennt werden. Die Wartungsmaßnahmen müssen von einem qualifizierten Fachmann durchgeführt werden, dem der Umgang mit Kühlflüssigkeiten vertraut ist.

5.2 Winterzeit

- Stellen Sie die Heizpumpenanlage auf den Modus "OFF".
- Trennen Sie die Heizpumpenanlage von der Stromversorgung.
- Leeren Sie den Kondensator mit Hilfe des Wasserablassers, um jegliche Schadensgefahr zu vermeiden. (großes Frostrisiko).
- Schließen Sie den By-pass-Schieber und lösen Sie die Eingangs- und Ausgangsverbindungsstücke.
- Entfernen Sie so gut es geht das Altwasser im Kondensator mit Hilfe einer Druckluftpistole.
- Verschließen Sie den Wasserein- und -ausgang an der Heizpumpenanlage, um das Eindringen von Fremdkörpern zu verhindern.
- Decken Sie die Heizpumpenanlage mit der für diesen Zweck vorgesehenen Winterschutzhülle ab.



Jeglicher Schaden, der durch eine schlechte Winterlagerung entsteht, hebt alle Garantieansprüche auf.

6. ANHANG

6.1 Stromtafel

HP5081DT3LVM / HP5111DT3LV

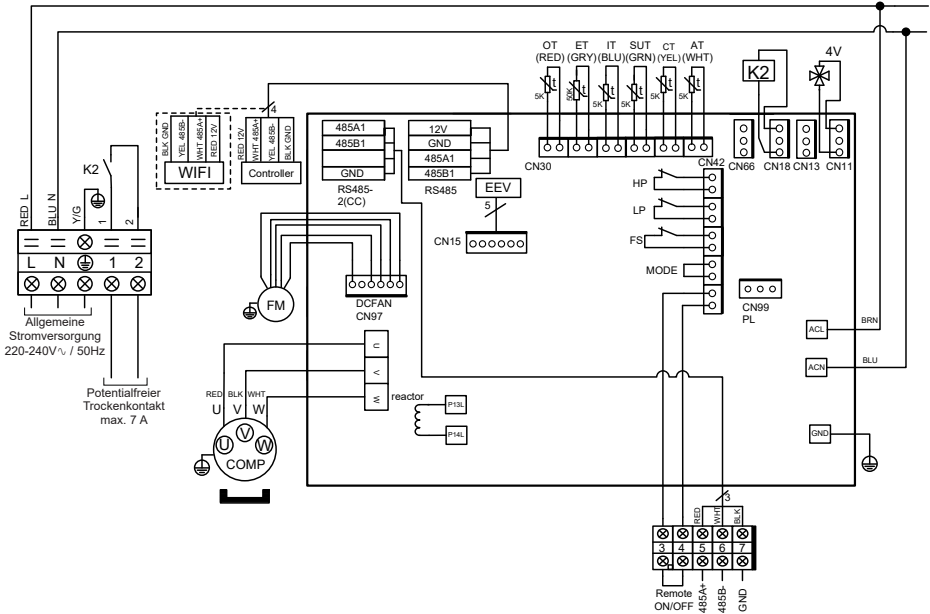

LEGENDE

- | | |
|---|---|
| AT : AUSSENTEMPERSURSENSOR | LP : NIEDRIGDRUCKREGLER |
| COMP : KOMPRESSOR | OT : SENSOR DER TEMPERATUR DES WASSERAUSLASSES |
| CT : TEMPERATURSENSOR DES EVAPORATORS | SUT : SENSOR DER SAUGTEMPERATUR |
| EEV : ELEKTRONISCHER SENSOR | 4V : 4-WEGE-VENTIL |
| FM : GEBLÄSEMOTOR | K2 : POTENTIALFREIER TROCKENKONTAKT MAX. 7 A |
| FS : SENSOR DES WASSERSTANDES | ET : DRUCKTEMPERATURSONDE |
| HP : HOCHDRUCKREGLER | ----- : OPTION |
| IT : SENSOR DER TEMPERATUR DES WASSEREINLASSES | |

6. ANHANG (Fortsetzung)

HP5151DT3LV

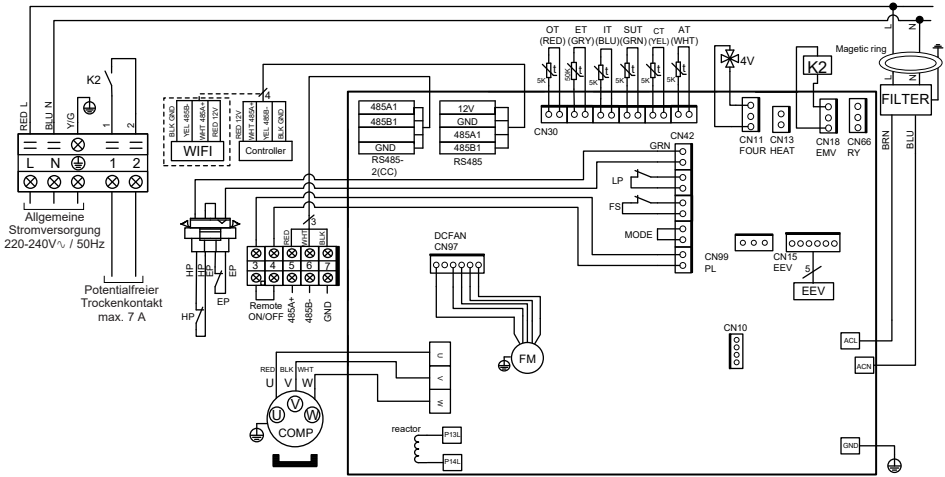

LEGENDE

- | | |
|--|--|
| AT : AUSSENTEMPERATURSENSOR | LP : NIEDRIGDRUCKREGLER |
| COMP : KOMPRESSOR | OT : SENSOR DER TEMPERATUR DES WASSERAUSLASSES |
| CT : TEMPERATURSENSOR DES EVAPORATORS | SUT : SENSOR DER SAUGTEMPERATUR |
| EEV : ELEKTRONISCHER SENSOR | 4V : 4-WEGE-VENTIL |
| FM : GEBLÄSEMOTOR | K2 : POTENTIALFREIER TROCKENKONTAKT MAX. 7 A |
| FS : SENSOR DES WASSERSTANDES | ET : DRUCKTEMPERATURSONDE |
| HP : HOCHDRUCKREGLER | ----- : OPTION |
| IT : SENSOR DER TEMPERATUR DES WASSEREINLASSES | |

6. ANHANG (Fortsetzung)

6.2 Vorrangige Heizanschlüsse einphasige Pumpe

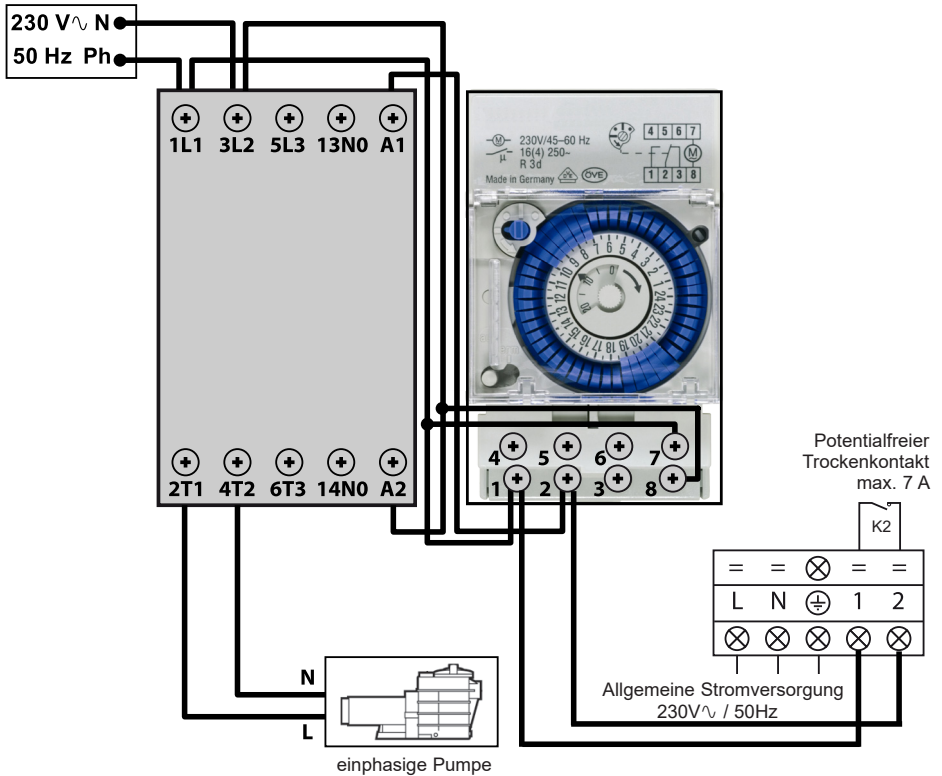

Die Anschlüsse 1 und 2 liefern einen potenzialfreien Trockenkontakt ohne Polarität 230 V \sim / 50 Hz.

Verkabeln Sie die Anschlüsse 1 und 2 unter Berücksichtigung des folgenden Kabelschemas, um die Filtrationspumpe jede Stunde in einem 2-Minuten-Zyklus zu aktivieren, wenn die Temperatur des Beckens unter den Sollwert fällt.



Die Stromversorgung der Filtrationspumpe niemals direkt an die Anschlüsse 1 und 2 anschließen.

6. ANHANG (Fortsetzung)

6.3 Explosionszeichnungen und Einzelteile

HP5081DT3LV / HP5111DT3LV / HP5151DT3LV

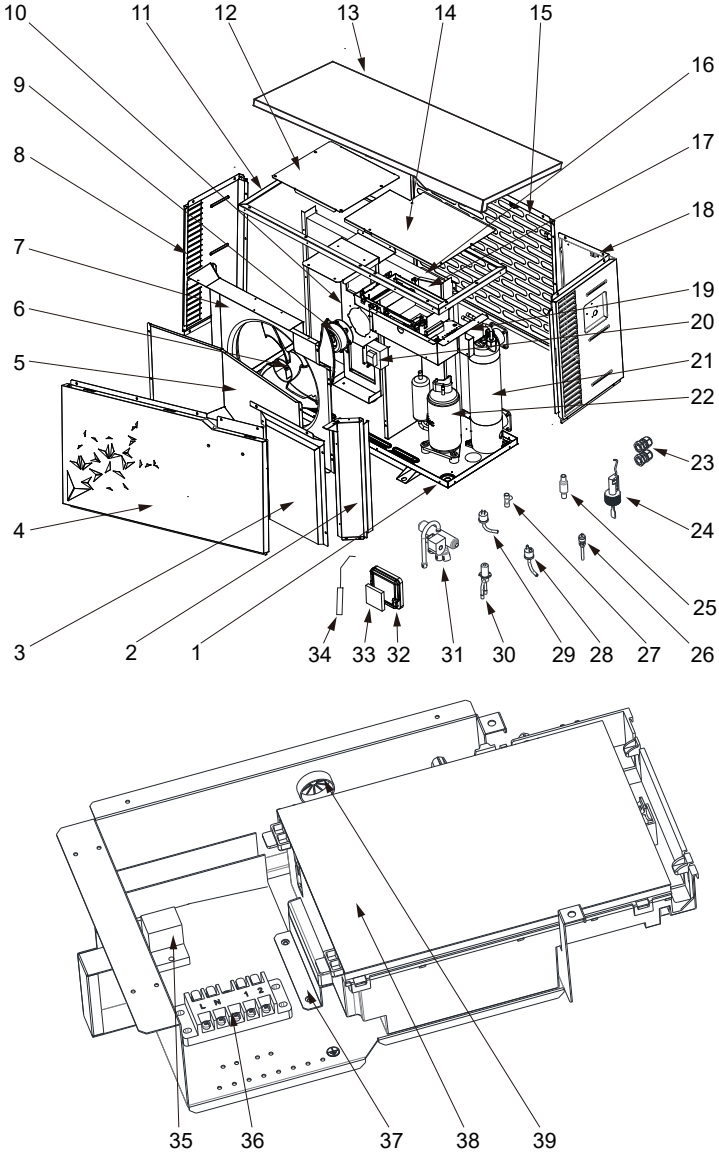

6. ANHANG (Fortsetzung)

Nr	Beschreibung	Ref.	HP5081DT3LV	HP5111DT3LV	HP5151DT3LV
1	/	/	/	/	/
2	/	/	/	/	/
3	/	/	/	/	/
4	Schild Vorne	HWX80715842	✓	✓	n/a
		HWX80715857	n/a	n/a	✓
5	/	/	/	/	/
6	Gebläsepropeller	HWX301030000006	✓	✓	n/a
		HWX20000270004	n/a	n/a	✓
7	/	/	/	/	/
8	Linkes Schild	HWX80713420	✓	✓	n/a
		HWX80713423	n/a	n/a	✓
9	Motor Ventilator DC	HWX80200018	✓	✓	n/a
		HWX20000330132	n/a	n/a	✓
10	Motorträger	HWX80708597	✓	✓	n/a
		HWX80709977	n/a	n/a	✓
11	/	/	/	/	/
12	/	/	/	/	/
13	Obere Platte	HWX80708601	✓	✓	n/a
		HWX80709984	n/a	n/a	✓
14	/	/	/	/	/
15	Rückplatte	HWX80710829	✓	✓	n/a
		HWX80710966	n/a	n/a	✓
16	Flügelevaporator	HWX80600849	✓	n/a	n/a
		HWX80600781	n/a	✓	n/a
		HWX80600835	n/a	n/a	✓
17	/	/	/	/	/
18	Rechtes Schild	HWX80713421	✓	✓	n/a
		HWX80713424	n/a	n/a	✓
19	/	/	/	/	/
20	Reaktanz	HWX82500020	✓	✓	n/a
		HWX82500021	n/a	n/a	✓
21	Titan/PVC--Kondensator	HWX80600939	✓	n/a	n/a
		HWX80600940	n/a	✓	✓
		HWX80600096	n/a	n/a	✓
22	Kompressor	HWX20000110448	✓	✓	n/a
		HWX80100046	n/a	n/a	✓
23	Stopfbuchse	HWX20012249	✓	✓	n/a
		HWX20012238	n/a	n/a	✓
24	Sensor des Wasserdurchsatzes	HWX83000068	✓	✓	✓
25	Filter Ø9.7-Ø9.7 (Ø19)	HWX20000140178	✓	✓	n/a
	Filter Ø9.7-Ø9.7 (Ø28)	HWX20041444	n/a	n/a	✓
26	Druckanschluss 40mm-1/2"	HWX20000140150	✓	✓	✓
27	Stecker T Ø9.52-2 xØ6.35(T) x 1.0	HWX30403000002	✓	✓	n/a
	Stecker T Ø6.5-2 x Ø6.5(T) x 0.75	HWX20001460	n/a	n/a	✓
28	Druckregler Niederdruck NO 0.30MPa/0.15MPa	HWX20000360157	✓	✓	✓
29	Druckregler Hochdruck NC 3.2MPa/4.4MPa	HWX20013605	✓	✓	✓
30	Elektronischer Anlasser	HWX81000011	✓	✓	n/a
		HWX81000017	n/a	n/a	✓
31	4-Wege-Ventil	HWX20041437	✓	✓	n/a
		HWX20000140485	n/a	n/a	✓
32	Halterung Steuereinheit	HWX80901004	✓	✓	✓
33	Steuereinheit LCD / Bluetooth	HWX72200312	✓	✓	✓

6. ANHANG (Fortsetzung)

HP5081DT3LV / HP5111DT3LV / HP5151DT3LV

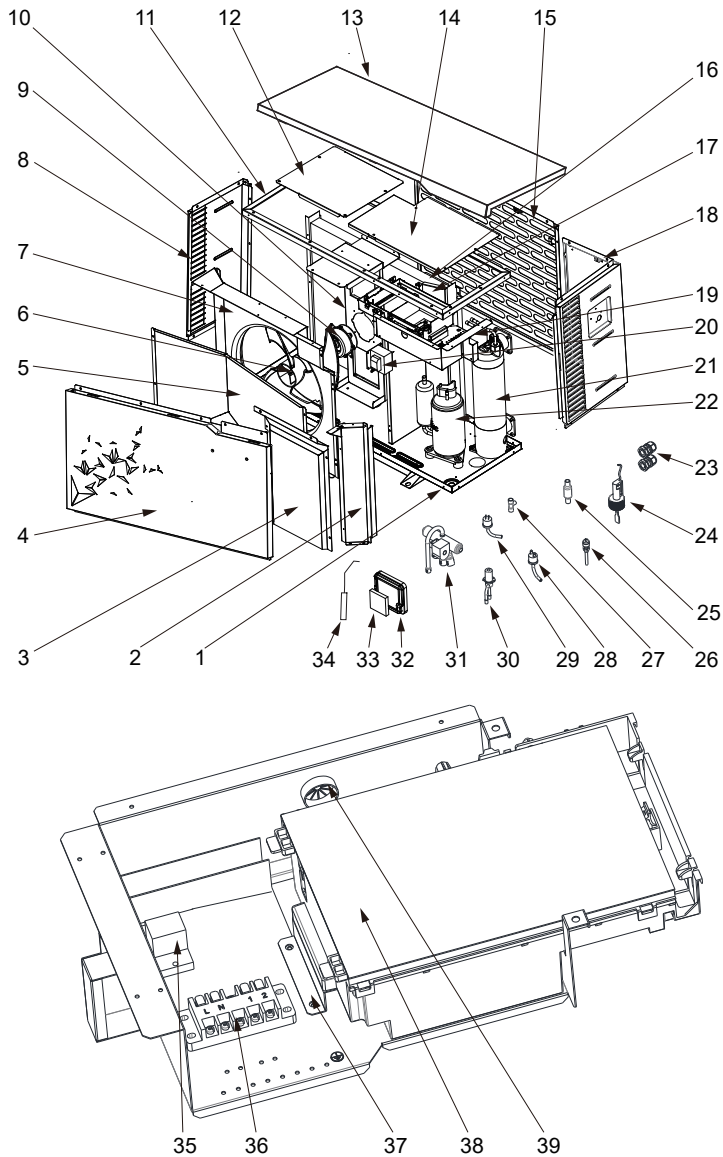

6. ANHANG (Fortsetzung)

Nr	Beschreibung	Ref.	HP5081DT3LV	HP5111DT3LV	HP5151DT3LV
34	Sensor des Wasserauslasses 5k-410mm	HWX83000050	✓	✓	✓
	Sensor des Wassereinlasses 5k-850mm	HWX83000052	✓	✓	✓
	Abgabekompressorsensor 50k-660mm	HWX83000026	✓	✓	✓
	Saugsonde des Kompressors 5k-560mm	HWX83000044	✓	✓	n/a
	Saugsonde des Kompressors 5k-760mm	HWX83000053	n/a	n/a	✓
	Abtausonde 5k-680mm	HWX83000051	✓	✓	n/a
	Abtausonde 5k-1040mm	HWX83000045	n/a	n/a	✓
	Lufttemperatursensor 5k-350mm	HWX83000049	✓	✓	✓
35	Relais K2	HWX20000360297	✓	✓	✓
36	Klemmleiste L-N-GND -5 Anschlüssen 4mm ²	HWX40003901	✓	✓	✓
37	/	/	/	/	/
38	Elektronische Treiberkarte	HWX72200168SL08	✓	n/a	n/a
		HWX72200168SL11	n/a	✓	n/a
		HWX72200168SL15	n/a	n/a	✓
39	/	/	/	/	/

6. ANHANG (Fortsetzung)

6.4 Anleitung zur Problembehandlung



Gewisse Arbeiten müssen von einem zugelassenen Techniker durchgeführt werden.

Im Falle einer Störung erscheinen die folgenden Anzeigen auf dem Bildschirm:

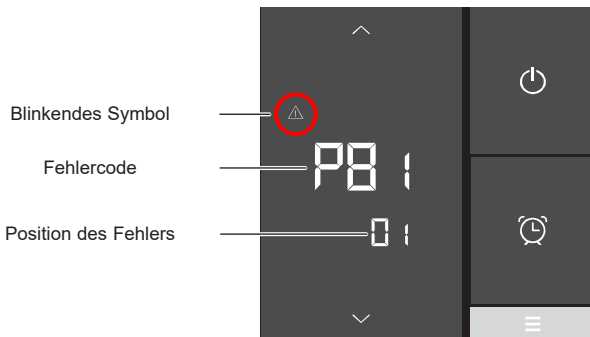

Sollte eine Störung vorliegen, drücken Sie auf  oder , um durch die Fehlercodes zu navigieren.

Ziehen Sie nachfolgende Tabelle zurate.



Nach Lösung des Problems wird der Fehler automatisch quittiert, das Dreieck erlischt.

6. ANHANG (Fortsetzung)

Störung	Fehlercode	Beschreibung	Lösung
Fehler Sonde Wassereingang (IT)	PO1	Der Sensor ist offen oder kurzgeschlossen	Den Anschluss am Verlängerungsstecker prüfen oder Sensor ersetzen
Fehler Sonde Wasserausgang (OT)	PO2		
Fehler Außen-temperatursonde (AT)	PO4		
Fehler Abtausonde (CT)	PO5		
Fehler Saugsonde Kompressor (SUT)	PO7		
Fehler Fördermengenfühler Kompressor (ET)	POB1		
Fehler Hochdruck	EO1	Der Sensor ist offen oder kurzgeschlossen	<p>Den Anschluss am Verlängerungsstecker prüfen oder Sensor ersetzen</p> <p>Wasserdurchfluss prüfen</p> <p>Wasserdurchflussmesser prüfen</p> <p>Öffnung der Ventile prüfen</p> <p>Druckausgleicher prüfen</p> <p>Verschmutzung des Verdampfers prüfen</p> <p>Wassertemperatur zu warm</p> <p>Problem von nicht kondensierbarem Material nach einer Wartung, Kältekreislaufs leeren und evakuieren.</p> <p>Zu hohe Kältemittelfüllung, Flüssigkeit in eine Flasche ableiten.</p>
Fehler Niederdruck	EO2	Der Sensor ist offen oder kurzgeschlossen	<p>Den Anschluss am Verlängerungsstecker prüfen oder Sensor ersetzen</p> <p>Großes Kältemittelleck, Leck mit Detektor suchen</p> <p>Zu geringer Luftstrom, Drehzahl des Ventilators prüfen</p> <p>Verschmutzung des Verdampfers prüfen, dessen Oberfläche reinigen</p>

6. ANHANG (Fortsetzung)

Störung	Fehlercode	Beschreibung	Lösung
Fehler Wasserdurchflussmesser	E03	Der Sensor ist offen oder kurzgeschlossen	Den Anschluss CN29/OVT an der Karte prüfen oder Sensor ersetzen
			Fehlendes Wasser, Funktion der Filterpumpe prüfen
			Öffnung der Absperrventile prüfen
			Einstellung des Druckausgleichers prüfen
Differenz Temperatur Eingang/ Ausgang > 13°C	E06	Nur im Modus Kalt anwendbar	Fehlendes Wasser, Funktion der Filterpumpe prüfen
			Öffnung der Absperrventile prüfen
			Einstellung des Druckausgleichers prüfen
Frostschutz	E07	Temperatur Wasserausgang < 4°C	Wärmepumpe stoppen, Kondensator leeren, Frostgefahr
Kommunikationsproblem	E08	Keine Kommunikation zwischen der elektronischen Karte und der Benutzeroberfläche	Verbindungen und Anschluss gemäß Schaltplan prüfen
Frostschutz Niveau 1	E19	2°C < Wassertemperatur < 4°C und Lufttemperatur < 0°C	Den Betrieb der Wärmepumpe anhalten, den Kondensator leeren, um Frostbildung zu verhindern; standardmäßig startet die Wärmepumpe die Filterpumpe, um Frostbildung zu verhindern
Frostschutz Niveau 2	E29	Wassertemperatur < 2°C und Lufttemperatur < 0°C	Den Betrieb der Wärmepumpe anhalten, den Kondensator leeren, um Frostbildung zu verhindern; standardmäßig startet die Wärmepumpe die Filterpumpe und die Wärmepumpe, um Frostbildung zu verhindern
Fehler Gebläsemotor	F03 I	Motor blockiert oder Anschlussfehler	Freie Drehung prüfen, den Anschluss CN97/DCFAN prüfen; Motor ersetzen
Fehler Gebläsemotor	F05 I	Anschlussfehler	Den Anschluss DCFAN/CN97 prüfen; Motor ersetzen
Außentemperatur zu niedrig	tP	Betriebsgrenze erreicht	Die Wärmepumpe ausschalten
Die Wärmepumpe startet nicht	- - - OFF	Kontakt (5-6) Remote On/Off offen	Kontakt (5-6) Remote On/Off schließen (siehe Schaltplan)

6. ANHANG (Fortsetzung)

6.5 Garantie

GARANTIEVORAUSSETZUNGEN

Für sämtliche HAYWARD-Produkte bestehen innerhalb von zwei Jahren ab Kauf des Produkts Garantien hinsichtlich sämtlicher Fertigungsfehler oder Materialmängel. Bei jedem Antrag auf Garantie muss der Nachweis des Kaufs, einschließlich des Belegs zum Kaufdatum, erbracht werden. Wir bitten Sie also um Aufbewahrung Ihrer Rechnung.

Die HAYWARD-Garantie, die grundsätzlich ganz im Ermessen von HAYWARD liegt, beschränkt sich auf die Reparatur oder den Ersatz, hinsichtlich fehlerhafter Produkte, sofern sie sachgemäß benutzt wurden, nämlich in Übereinstimmung mit den im Benutzerleitfaden befindlichen Vorschriften; das Produkt darf keinesfalls verändert worden sein und darf ausschließlich mit den Bauteilen und Einzelteilen von HAYWARD benutzt werden. Die Garantie erstreckt sich nicht auf Beschädigungen aufgrund von Frost und Einwirkungen chemischer Substanzen.

Ausgeschlossen von der Garantie sind sämtliche sonstigen Kosten (Transport, Arbeitstätigkeit...). HAYWARD kann nicht haftbar gemacht werden für direkte oder indirekte Schäden, die sich aufgrund falscher Montage, fehlerhaften Anschlusses oder der falschen Funktion des Produkts ergeben.

Falls Sie einen Garantieantrag stellen, eine Reparatur beantragen oder ein Produkt austauschen möchten, so wenden Sie sich bitte an Ihren Händler. Ausgeschlossen ist eine Material-Rücksendung an unser Werk ist ohne unsere vorherige schriftliche Zustimmung.

Die Verschleißteile unterliegen nicht der Garantie.

Seite bewusst leer gelassen



S.Line Pro *Fi*

ZWEMBAD WARMTEPOMP



Installatie- en bedieningshandleiding

INHOUD

1. VOORWOORD	1
---------------------	----------

2. TECHNISCHE EIGENSCHAPPEN	4
2.1 Technische gegevens over de warmtepomp	4
2.2 Werkgebied	5
2.3 Afmetingen	6

3. INSTALLATIE EN AANSLUITING	7
3.1 Basisschema	7
3.2 Warmtepomp	7
3.3 Hydraulische aansluiting	8
3.4 Elektrische aansluiting	9
3.5 Eerste gebruik	10

4. GEBRUIKERSINTERFACE	12
4.1 Algemene voorstelling	12
4.2 Regeling van het waterdebiet	14
4.3 Instelling van de klok	15
4.4 Instelling van de Timers Start / Stop	15
4.5 Instelling van de Timer-functie in STILLE modus	17
4.6 Bluetooth-koppeling - Bediening op afstand	18
4.7 Selectie van de werkingsmodus	19
4.8 Instellen en visualiseren van de gewenste waarde	20
4.9 Het touchscreen vergrendelen en ontgrendelen	21

5. ONDERHOUD EN OVERWINTERING	22
5.1 Onderhoud	22
5.2 Overwintering	22

6. BIJLAGEN	23
6.1 Elektrische schema's	23
6.2 Aansluitingen prioriteit verwarming eenfasepomp	25
6.3 Opengewerkte tekeningen en onderdelen	26
6.4 Storingsgids	30
6.5 Garantie	33

Aandachtig lezen en bewaren voor later gebruik.

Dit document moet aan de eigenaar van het zwebad overhandigd en door hem op een veilige plaats bewaard worden.

1. VOORWOORD

Hartelijk dank voor de aanschaf van deze Hayward zwembadwarmtepomp. De S.LINE PRO warmtepomp is ontworpen volgens strenge productienormen om te voldoen aan de hoogste kwaliteitseisen.

De S.LINE PRO warmtepompen bieden u uitzonderlijke prestaties terwijl gedurende het hele zwemseizoen door het vermogen, het elektriciteitsverbruik en het geluidsniveau aan te passen aan de verwarming van uw zwembad dankzij de FULL INVERTER-besturingslogica.



Lees de instructies in deze handleiding zorgvuldig door voordat u het apparaat in gebruik neemt.

S.LINE PRO warmtepompen zijn uitsluitend bedoeld voor het verwarmen van zwembadwater, gebruik deze apparatuur niet voor andere doeleinden.

Deze handleiding bevat alle noodzakelijke informatie over installatie, probleemoplossing en onderhoud.

Lees deze handleiding zorgvuldig door voordat u het apparaat opent of onderhoudswerkzaamheden aan het apparaat uitvoert. De fabrikant van dit product is in geen geval aansprakelijk voor enig letsel van een gebruiker of schade aan het apparaat als gevolg van mogelijke fouten tijdens de installatie, het verhelpen van storingen of onnodig onderhoud. Het is van essentieel belang om de instructies in deze handleiding te allen tijde op te volgen.

Elke aanbeveling die niet wordt opgevolgd, maakt de garantie ongeldig.

VOORWOORD (vervolg)



Veiligheidsinstructies



Dit apparaat bevat R32.

Gebruik nooit een ander koelmiddel dan R32. Elk ander gasvormig lichaam vermengd met de R32 kan abnormaal hoge drukken veroorzaken die kunnen leiden tot breuken in leidingen en/of persoonlijk letsel.

Gebruik bij reparatie- of onderhoudswerkzaamheden koperen buizen die voldoen aan norm EN 12375-1 (mei 2020) en de Europese richtlijn drukapparatuur 97/23 / EG.

Omdat de warmtepomp onder druk staat, mag u nooit gaten boren in de leidingen of proberen deze te solderen. Er bestaat explosiegevaar.

Stel het apparaat nooit bloot aan vlammen, vonken of andere ontstekingsbronnen. Het kan ontploffen en ernstige of zelfs dodelijke verwondingen veroorzaken.



De warmtepomp is uitsluitend bestemd voor installatie buiten gebouwen.

- In geval van opslag moet de warmtepomp worden opgeslagen in een goed geventileerde ruimte met een vloeroppervlakte van meer dan A_{\min} (m²) volgens de volgende formule: $A_{\min} = (M / (2,5 \times 0,22759 \times h_0))^2$
M is de koelmiddelvulling in het apparaat in kg en h₀ is de opslaghoogte. Voor grondopslag h₀ = 0,6 m.
- Het apparaat moet door gekwalificeerd personeel worden geïnstalleerd.
- Installeer de warmtepomp niet op een steun die de trillingen van het apparaat kan versterken.
- Controleer of de bijgeleverde beugel voor het apparaat de juiste maat heeft voor het gewicht van het apparaat.
- Installeer de warmtepomp niet op een plaats waar het geluidsniveau kan worden versterkt of op een plaats waar het geluid van het apparaat de buurt kan verstoren.
- Alle elektrische aansluitingen moeten worden uitgevoerd door een gekwalificeerde elektromonteur en in overeenstemming met de geldende normen in het land van installatie, zie § 3.4.
- Schakel de hoofdstroomtoevoer en de hoofdschakelaar uit voordat u elektrische werkzaamheden uitvoert. Elke nalatigheid kan elektrische schokken veroorzaken.

VOORWOORD (vervolg)

- Controleer voor de installatie of de aardkabel niet is doorgeknipt of losgekoppeld.
- Sluit de voedingskabel goed aan en draai deze goed vast. Als de aansluiting niet correct is, kunnen elektrische onderdelen beschadigd raken.
- Blootstelling van de warmtepomp aan water of een vochtige omgeving kan elektrocutie veroorzaken. Wees voorzichtig.
- Als u een defect of een abnormale situatie constateert, stop dan de installatie van de warmtepomp en neem onmiddellijk contact op met uw dealer.
- Onderhoud en diverse bewerkingen moeten worden uitgevoerd met de aanbevolen frequentie en tijden, zoals aangegeven in deze handleiding.
- Reparaties moeten worden uitgevoerd door gekwalificeerd personeel.
- Gebruik alleen originele reserveonderdelen.
- Gebruik nooit een andere reinigingsprocedure dan die welke in deze handleiding wordt aanbevolen.

Belangrijke informatie over het gebruikte koelmiddel

Dit product bevat gefluoreerde broeikasgassen die onder het Kyoto-protocol vallen. Laat deze gassen niet in de atmosfeer vrijkomen.

Type koelmiddel R32

GWP-waarde(1): 675, Waarde gebaseerd op het 4e IPCC-rapport.

De hoeveelheid koudemiddel op basis van de F Gas 517/2014 regeling staat aangegeven op het typeplaatje van het apparaat.

Afhankelijk van de Europese of lokale wetgeving kunnen periodieke koelmiddellekkage-inspecties vereist zijn. Neem contact op met uw lokale distributeur voor meer informatie.

(1) Aardopwarmingsvermogen

2. TECHNISCHE EIGENSCHAPPEN

2.1 Technische gegevens over de warmtepomp

Modellen	S.LINE PRO	HP5081DT3LV	HP5111DT3LV	HP5151DT3LV
Voedingsspanning	V	220V-240V ~ / 1ph / 50Hz		
Koelmiddel	/	R32		
Belasting	kg	0,45	0,50	0,65
Massa in TCO ₂	/	0,30	0,34	0,44
Frequentie van de controle op lekkage	/	Geen eisen, maar jaarlijks geadviseerd		
Verwarmingscapaciteit Min--Max ^(a)	kW	2,83 -- 8,16	1,95 -- 10,90	5,27 -- 15,66
Opgenomen elektrisch vermogen Min--Max ^(a)	kW	0,212 -- 1,19	0,150 -- 1,92	0,457 -- 2,80
Nominale bedrijfstrom Min--Max ^(a)	A	1,41 -- 5,20	1,05 -- 8,49	2,04 -- 12,28
COP Max--Min ^(a)	/	13,30 -- 6,81	12,92 -- 5,67	11,53 -- 5,59
Verwarmingscapaciteit Min--Max ^(b)	kW	1,77 -- 5,91	1,86 -- 8,40	3,81 -- 11,67
Opgenomen elektrisch vermogen Min--Max ^(b)	kW	0,31 -- 1,28	0,30 -- 1,83	0,588 -- 2,71
COP Max--Min ^(b)	/	5,70 -- 4,62	6,20 -- 4,59	6,48 -- 4,31
Maximale bedrijfstrom (MBS)	A	6,50	10,30	14
Vermogen van de zekering	g/G	10	12	16
C-curve stroomonderbreker	C	10	12	16
Startstroom	A	< MBS		
Hydraulische aansluiting	mm	50 mm		
Nominaal waterdebiet ^(a)	m ³ /h	3,50	4,60	6,70
Max. waterdrukverlies	kPa	8	5	10
Compressor	/	DC Inverter MITSUBISHI ELECTRIC		DC Inverter Mitsubishi
Type	/	Dubbele roterende		Dubbele roterende
Hoeveelheid	/	1		
Wikkelweerstand bij 20°C	Ohm	1,91 +/- 5%		0,95 +/- 5%
Ventilator	/	Axiaal		
Hoeveelheid	/	1		
Diameter	mm	405		500
Aantal bladen	/	3		
Motor	/	DC-omvormer		
Hoeveelheid	/	1		
Rotatiesnelheid	Tr/min	500 -- 800	500 -- 900	500 -- 750
Snelheid Stille modus	Tr/min	500	500	500
Geluidsrukniveau op 1 m	dB(A)	45,1	48,6	54,1
Geluidsrukniveau op 10 m	dB(A)	27,9	31,6	36,9
Netto afmetingen van de eenheid (B-I-H)	mm	1011 / 430 / 622		1025 / 480 / 768
Gewicht	kg	61	61	87



(a) Droge lucht 27°C - Relatieve vochtigheid 78% - Watertoevoertemperatuur 26°C.

(b) Droge lucht 15°C - Relatieve vochtigheid 71% - Watertoevoertemperatuur 26°C

2. TECHNISCHE EIGENSCHAPPEN (vervolg)

2.2 Werkgebied

Gebruik de warmtepomp in volgende temperatuur- en vochtigheidsbereiken om een correct en efficiënt te garanderen.

	Verwarmingsmodus 	Afkoelingsmodus 
Buitentemperatuur	-7°C – +35°C	+7°C – +43°C
Watertemperatuur	+12°C – +32°C	+8°C – +40°C
Relatieve vochtigheid	< 80%	< 80%
Instelbereik van de gewenste waarde	+15°C – +32°C	+8°C – +32°C



Als de temperatuur of de vochtigheid niet aan deze voorwaarden voldoet, kunnen beveiligingen losraken en kan de warmtepomp niet meer werken.



De maximale verwarmingstemperatuur is 32°C om beschadiging van de liners te voorkomen. Hayward wijst alle aansprakelijkheid af in geval van gebruik boven 32°C.

2. TECHNISCHE EIGENSCHAPPEN (vervolg)

2.3 Afmetingen

Modellen :

HP5081DT3LV / HP5111DT3LV / HP5151DT3LV

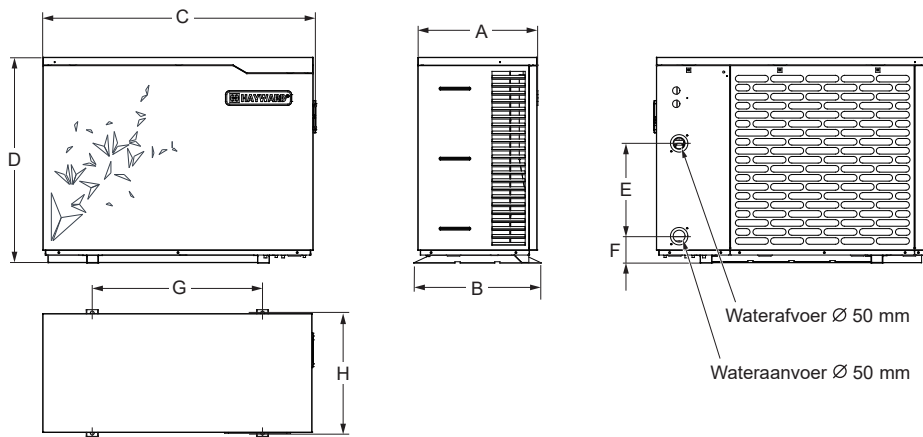

Unit : mm

Merkteken	Modell	HP5081DT3LV / HP5111DT3LV	HP5151DT3LV
A		393	453
B		430	480
C		1011	1030
D		621,5	776
E		350	350
F		97,5	102
G		625	645
H		406	456

3. INSTALLATIE EN AANSLUITING

3.1 Basisschema

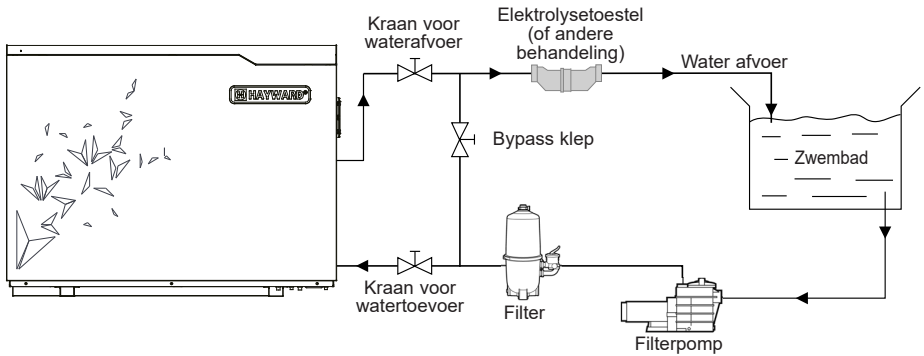

Opmerking : Met de warmtepomp wordt geen randapparatuur of filter meegeleverd. De onderdelen op het schema moeten door de installateur voorzien worden.

3.2 Warmtepomp



Plaats de pomp en openlucht en buiten een gesloten technisch lokaal.

De installatie moet beschut staan en de hieronder voorgeschreven minimumafstanden moeten gerespecteerd worden om luchtterugvoer en een minder goede werking van de warmtepomp te voorkomen

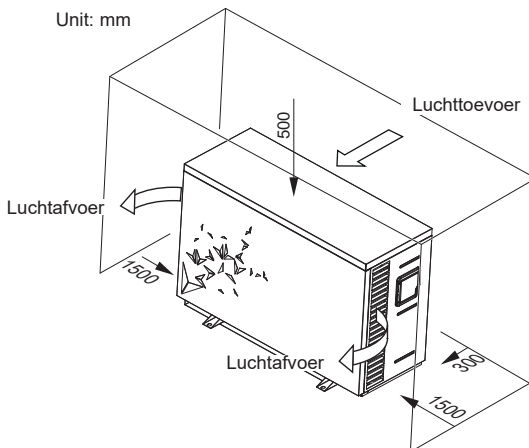

3. INSTALLATIE EN AANSLUITING (vervolg)



Installeer de warmtepomp bij voorkeur op een betonplaat of een bevestigingsstoel die voor dit doeleinde voorzien is en installeer de warmtepomp op de voorziene silentblokken (schroeven en rondellen niet meegeleverd).

De maximumafstand tussen de warmtepomp en het zwembad is 15 meter.

De totale lengte van de hydraulische leidingen is 30 meter.

De bovengrondse en ondergrondse hydraulische kanalen isoleren.

De warmtepomp moet op een minimum afstand van het bassin worden geïnstalleerd conform de NF C 15-100 (dat wil zeggen op 3,5 m van het waterbassin voor Frankrijk) of conform de geldende installatienormen in andere landen.

Installeer de waterpomp niet in de buurt van een warmtebron.

In geval van installatie in regio's waar het geregeld sneeuwt, wordt aangeraden het apparaat overdekt te installeren om te voorkomen dat er zich sneeuw op de verdamper opstapelt.

3.3 Hydraulische aansluiting

De warmtepomp is voorzien van 2 aansluitingen met een diameter van 50 mm. Gebruik PVC-buizen voor de hydraulische leidingen Ø 50 mm. Sluit de watertoevoer van de warmtepomp op de leiding die van de filtergroep komt en sluit daarna de waterafvoer van de warmtepomp op de waterleiding die naar het zwembad loopt (cv tekening hieronder).

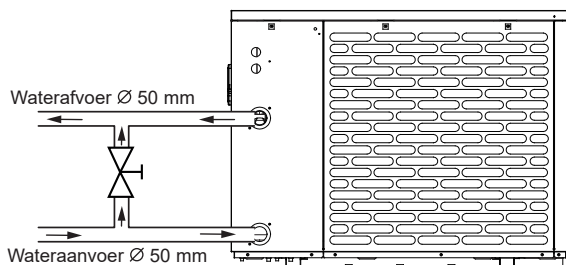

Installeer een bypassklep tussen de in- en uitgang van de warmtepomp.



Als u een automatische distributeur of een elektrolyseapparaat gebruikt, moet deze na de warmtepomp geïnstalleerd worden om de Titanium condensor tegen een te hoge concentratie aan chemische producten te beschermen.



Zorg ervoor dat de bypassklep en de aansluitingen op de aan- en afvoer van het water goed geïnstalleerd zijn om de drainage tijdens de winterperiode, de toegang en de demontage voor onderhoud te vergemakkelijken.

3. INSTALLATIE EN AANSLUITING (vervolg)

3.4 Elektrische aansluiting



De elektrische installatie en de bekabeling van deze uitrusting moeten conform zijn met de plaatselijk geldende normen.

F	NF C15-100	GB	BS7671:1992
D	DIN VDE 0100-702	EW	EVHS-HD 384-7-702
A	ÖVE 8001-4-702	H	MSZ 2364-702/1994/MSZ 10-553 1/1990
E	UNE 20460-7-702 1993, RECBT ITC-BT-31 2002	M	MSA HD 384-7-702.S2
IRL	Wiring Rules + IS HD 384-7-702	PL	PN-IEC 60364-7-702:1999
I	CEI 64-8/7	CZ	CSN 33 2000 7-702
LUX	384-7.702 S2	SK	STN 33 2000-7-702
NL	NEN 1010-7-702	SLO	SIST HD 384-7-702.S2
P	RSIUEE	TR	TS IEC 60364-7-702



Controleer of de elektrische voeding en de netwerkfrequentie overeenstemmen met de vereiste werkstroom, door rekening te houden met de specifieke plaatsing van het toestel en de noodzakelijke stroom om alle andere toestellen die op hetzelfde circuit aangesloten zijn, te voeden.

**HP5081DT3LV / HP5111DT3LV / HP5151DT3LV
230V ~ +/- 10 % 50 Hz 1 Fase**

**Bestudeer het overeenkomstige bedradingschema in bijlage.
Drie connecties zijn voor de elektrische voeding en twee voor de besturing van de warmtepomp (Bediening).**

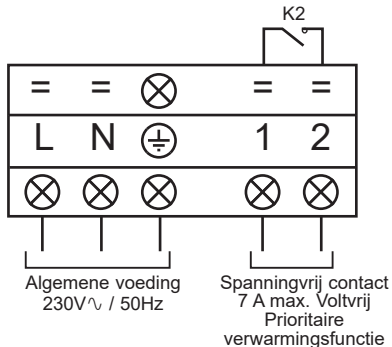

3. INSTALLATIE EN AANSLUITING (vervolg)



De elektrische voedingskabel moet, op gepaste manier, voorzien zijn van een beveiligingszekering van het type motorvoeding (gG) of een stroomonderbreker met C-curve en een differentieelschakelaar 30mA (zie tabel hieronder).

Modellen		HP5091DT3H	HP5111DT3H	HP5151DT3H
Elektrische voeding	V/Ph/ Hz	230V~ 50Hz	230V~ 50Hz	230V~ 50Hz
Smeltzekering type gG	A	10 gG	12 gG	16 gG
Stroomonderbreker met C-curve	A	10 C	12 C	16 C
Kabelsectie	mm ²	3G 2,5	3G 2,5	3G 2,5



Gebruik een voedingskabel van het type RO 2V / R 2V of equivalent.



De kabelsecties worden gegeven voor een maximale lengte van 25 m. Deze moeten echter worden gecontroleerd en aangepast afhankelijk van de installatieomstandigheden.



Schakel altijd de hoofdschakelaar uit alvorens de elektriciteitsdoos te openen.

3.5 Eerste gebruik

Opstartprocedure - zodra de installatie beëindigd is, moet u de volgende stappen volgen en respecteren :

- 1) Draai de ventilatoren handmatig om te controleren of deze met de hand gedraaid kunnen worden en of het blad op de motorboom bevestigd is.
- 2) Controleer of de eenheid correct op de hoofdvoeding aangesloten is (zie bedradingsschema in bijlage).
- 3) Activeer de filterpomp.
- 4) Controleer of alle waterkleppen openstaan en dat het water naar de eenheid loopt alvorens in verwarming of koeling opstart.
- 5) Controleer of de drainageleiding correct vastgemaakt is en niet verstopt is.
- 6) Schakel de elektrische voeding van de eenheid in en druk daarna op de Start/Stop-knop  op het controlepaneel.

3. INSTALLATIE EN AANSLUITING (vervolg)

- 7) Zorg ervoor dat de alarm- of vergrendelingsymbolen niet verschijnen. Raadpleeg, indien nodig, de gids voor het oplossen van problemen (zie § 6.4).
- 8) Leg het waterdebiet vast met behulp van de bypassklep (zie § 2.1 en 4.2), zoals respectievelijk vastgelegd is voor ieder model, zodat er een temperatuurverschil van 2°C is tussen het Binnenkomend en Uitgaand water.
- 9) Wanneer het toestel enkele minuten gedraaid heeft, controleer dan dat de lucht die eruit komt, afgekoeld is (tussen 5°C en 10°C).
- 10) Stop de filterpomp terwijl de eenheid blijft draaien. De eenheid moet automatisch stoppen en de foutcode E03 weergeven.
- 11) Laat de eenheid en de zwembadpomp 24u op 24u draaien totdat de gewenste watertemperatuur bereikt is. Wanneer het binnenkomend water de gewenste temperatuur bereikt heeft, zal de eenheid stilvallen. Ze zal automatisch opstarten (als de zwembadpomp in werking is) als de temperatuur van het zwembad 0.5°C lager is dan de gewenste temperatuur.

Debietschakelaar - De eenheid is voorzien van een debietschakelaar die de warmtepomp inschakelt wanneer de filterpomp van het zwembad in werking is, en uitschakelt wanneer de de filterpomp stopt. Bij onvoldoende water zal de alarmcode E03 op de schakelaar getoond worden (Zie § 6.4).

Vertraging - De eenheid vertoont een vertraging van 3 minuten om de onderdelen van het besturingscircuit te beschermen en om onregelmatige opstart en storingen van de contactor te vermijden. Dankzij deze vertraging start de eenheid automatisch op ongeveer 3 minuten na een stroomonderbreking. Zelfs een korte stroomonderbreking zal de uitgestelde start activeren.

4. GEBRUIKERSINTERFACE

4.1 Algemene voorstelling

De warmtepomp is uitgerust met een digitaal bedieningspaneel mat aanraaktoetsen, elektrisch aangesloten en in de fabriek vooraf ingesteld op de verwarmingsmodus.

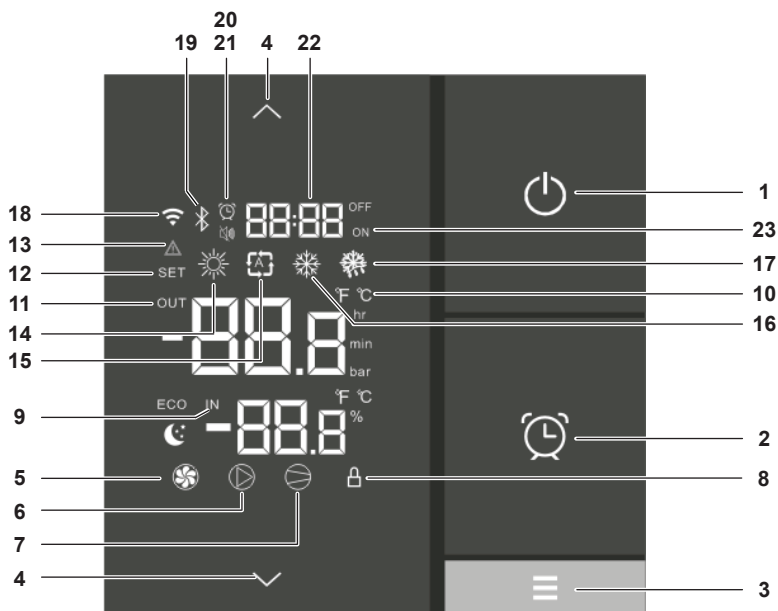

Legenda

1		Start / Stop / Annuleren
2		Uurregeling en Timer
3		De gebruiksmodus selecteren
4		Omhoog scrollen / Omlaag scrollen, +°C / -°C
5		Ventilator ON
6		Droog contact OUT2 ON
7		Compressor ON
8		Scherm vergrendeld
9		Wateraanvoer
10		Celsius / Fahrenheit
11		Waterafvoer
12		Instelling geavanceerde parameters

13		Storing systeem
14		Verwarmingsmodus
15		Automatische modus
16		Afkoelingsmodus
17		Modus de-icing
18		NVT
19		Bluetooth-verbinding
20		Timer ingesteld
21		Verkliekerlampje stille modus / Timer
22		Uur / Uur van de timers
23		Timer ingesteld in Start en Stop

4. GEBRUIKERSINTERFACE (vervolg)

Modus OFF/UIT

Wanneer de warmtepomp in waakstand is (modus OFF) verschijnt de tekst "OFF" op het scherm van de regelaar en gaat het scherm in energiebesparing na één minuut.

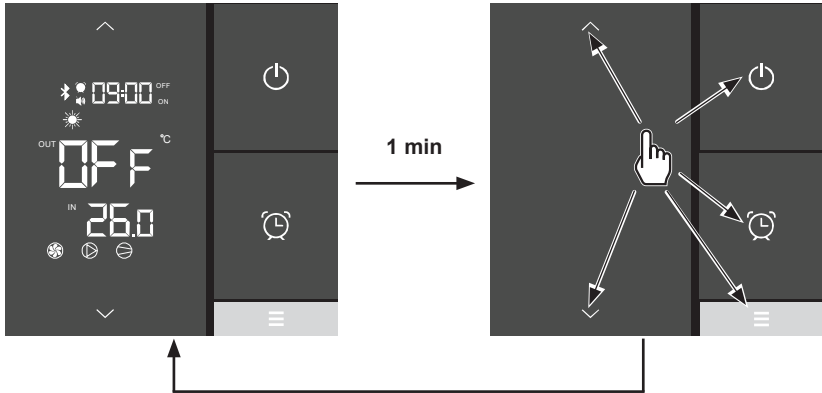

Druk op een willekeurige knop om terug te gaan naar de volledige weergave.

Modus ON

Wanneer de warmtepomp in werking is of bij het regelen (Modus ON), worden de ingangs- en uitgangstemperaturen van het water weergegeven op het scherm van de regelaar en gaat het scherm in energiebesparing na één minuut.

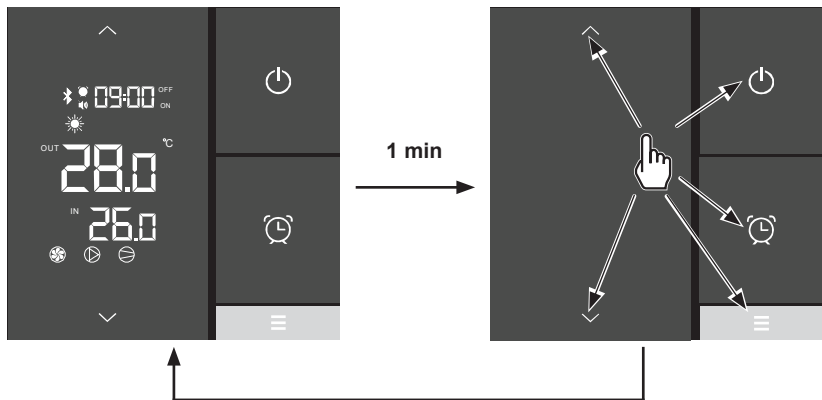

Druk op een willekeurige knop om terug te gaan naar de volledige weergave.

4. GEBRUIKERSINTERFACE (vervolg)

4.2 Regeling van het waterdebiet

Terwijl de inlaat- en uitlaatkleppen van het water afgedekt zijn, stelt u de zogenaamde “by-passklep” af om een verschil van 2°C te verkrijgen tussen de invoer- en uitvoertemperatuur van het water (zie principeschema § 3.1).

U kunt de regeling controleren door de invoer- en uitvoertemperatuur direct op het bedieningspaneel weer te geven in overeenstemming met onderstaande procedure.

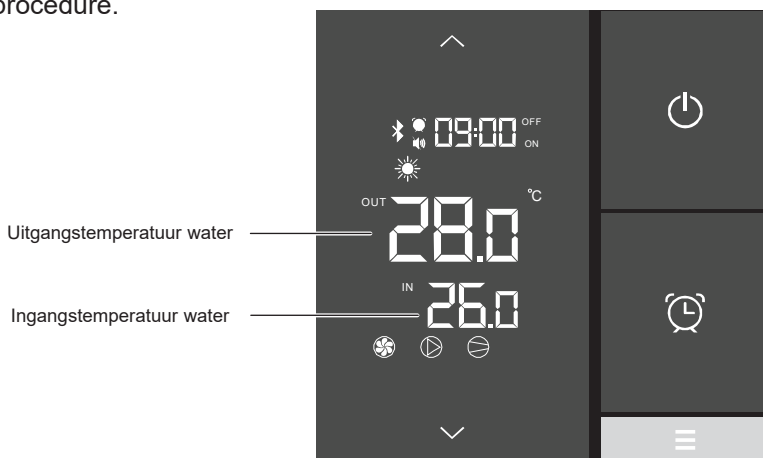

Stel vervolgens de “by-pass” in om een verschil van 2°C te verkrijgen tussen de invoer- en uitgangstemperatuur.

Druk op  om het menu te verlaten.

- Het sluiten van de “by-passklep” zorgt voor een lager debiet in de warmtewisselaar van de warmtepomp, waardoor er een groter verschil ontstaat in de in-/uitgangstemperatuur.
- Het sluiten van de “by-passklep” zorgt voor een hoger debiet in de warmtewisselaar van de warmtepomp, waardoor er een kleiner verschil ontstaat in de in-/uitvoertemperatuur.

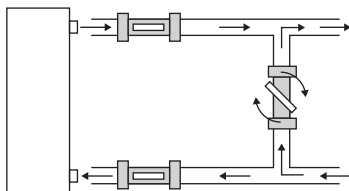









Het is mogelijk de instelling te controleren door de in-/ uitvoertemperatuur (1-2) rechtstreeks weer te geven in de app “EyesPool Inverter Connect” (zie § 4.6).

4. GEBRUIKERSINTERFACE (vervolg)

4.3 Instelling van de klok

Aan het einde van de instellingen, klik op  om te valideren.
De instellingen worden automatisch opgeslagen als er binnen 5 seconden niet op een knop gedrukt wordt.













- Druk op , de tijdweergave knippert.
- Druk op , de urenweergave knippert. Stel de uren in met behulp van de knoppen  en .
- Druk op  en stel de minuten in met behulp van de knoppen  en .
- Valideer door te drukken op .

4.4 Instelling van de Timers Start / Stop

De instelling van deze functie is noodzakelijk zodra u uw warmtepomp binnen een kortere termijn dan vastgelegd door de filterklok wilt gebruiken. Op die manier kunt u een uitgestelde start en een vroegtijdige uitschakeling programmeren of eenvoudigweg een periode waarin de pomp niet gebruikt mag worden (bijvoorbeeld 's nachts).

U beschikt over de mogelijkheid om een Timer Start (ON) en een Timer Stop (OFF) te programmeren.

Programmering van de Timer - Start (ON)

- Druk gedurende 2 seconden op  tot het pictogram  knippert.
- Druk op , de weergave  knippert ().
- Druk op  en stel de uren in met behulp van de knoppen  en .
- Druk op  en stel de minuten in met behulp van de knoppen  en .
- Valideer door te drukken op  en vervolgens op  om terug te gaan naar het hoofdscherm.

De instellingen worden automatisch opgeslagen als er binnen 20s niet op een knop gedrukt wordt.

De instelling van de minuten is mogelijk in schrijven van 10 minuten

De indicatie ON onder de tijdweergave op het hoofdscherm geeft aan dat de Timer Start (ON) werd geprogrammeerd.

4. GEBRUIKERSINTERFACE (vervolg)

Programmering van de Timer - Stop (OFF)







- Druk gedurende 2 seconden op  tot het pictogram  knippert
- Druk op , de weergave  knippert (**ON**).
- Druk op , de weergave  knippert (**OFF**).
- Druk op  en stel de uren in met behulp van de knoppen  en .
- Druk op  en stel de minuten in met behulp van de knoppen  en .
- Valideer door te drukken op  en vervolgens op  om terug te gaan naar het hoofdscherm.

De instellingen worden automatisch opgeslagen als er binnen 20s niet op een knop gedrukt wordt.

De instelling van de minuten is mogelijk in schrijven van 10 minuten



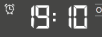



De indicatie OFF onder de tijdweergave op het hoofdscherm geeft aan dat de Timer Stop (OFF) werd geprogrammeerd.

Raadpleging van de Timers







- Druk gedurende 2 seconden op  tot het pictogram  knippert.
- Druk op , de tijdweergave van de Timer Start  knippert.
- Druk op , de tijdweergave van de Timer Stop  knippert.
- Druk op  om terug te gaan naar het hoofdscherm.

Het pictogram  wordt weergegeven op het hoofdscherm wanneer een Timer Start en/of Timer Stop wordt geprogrammeerd.

Verwijderen van de Timers Start (ON) en Stop (OFF)











- Druk gedurende 2 seconden op  tot het pictogram  knippert.
- Druk 2 keer op , de starttijden knipperen .
- Druk op  om de Timer Start  te verwijderen.

Aan het einde van stap 3, drukt u op  om terug te gaan naar het hoofdscherm of ga naar stap 4 om verder te gaan.

- Druk op  om toegang te krijgen tot de stoptijd .
- Druk op , de starttijden knipperen .
- Druk op  om de Timer Stop  te verwijderen.
- Druk op  om terug te gaan naar het hoofdscherm.

4. GEBRUIKERSINTERFACE (vervolg)

Verwijderen van de Timer Stop (OFF)

- Druk gedurende 2 seconden op  tot het pictogram  knippert.
- Druk 2 keer op  , de starttijden knipperen .
- Druk op  om toegang te krijgen tot de stoptijd .
- Druk op  de stoptijden knipperen .
- Druk op  om de Timer Stop  te verwijderen.
- Druk op  om terug te gaan naar het hoofdscherm.

4.5 Instelling van de Timer-functie in STILLE modus

In de STILLE modus werkt de warmtepomp in de economische modus en heel stil als de verwarmingsbehoefte laag is (handhaven van de temperatuur van het bassin of indien een ultrastille werking nodig is).

Programmering van de timer in de STILLE modus

- Druk gedurende 2 seconden op  tot het pictogram  knippert.
- Druk op  , tot het pictogram  knippert.
- Druk op  , tot de weergave  knippert.
- Druk op  om de starttijd in te stellen met hulp van de knoppen  en .
- Druk op  en vervolgens op  tot de weergave  knippert.
- Druk op  om de stoptijd in te stellen met behulp van de knoppen  en .
- Druk op  om te valideren en vervolgens op  om terug te gaan naar het hoofdscherm.

Verwijderen van de Timer in de STILLE modus

- Druk gedurende 2 seconden op  tot het pictogram  knippert.
- Druk op  , tot het pictogram  knippert.
- Druk op  , de tijdweergave van de Timer Start  knippert.
- Druk op  om enkel de uren te laten knipperen.
- Druk op  , tot de weergave  knippert.
- Druk op  om terug te gaan naar het hoofdscherm.

Het verwijderen van de Timer Aan leidt stelselmatig tot de verwijdering van de Timer Stop.

Het instellingsinterval is "van uur tot uur".

4. GEBRUIKERSINTERFACE (vervolg)

Raadplegen van de Timer in de Stille modus

- Druk gedurende 2 seconden op  tot het pictogram  knippert.
- Druk op , tot het pictogram  knippert.
- Druk op  om de starttijd weer te geven.
- Druk op  om de stoptijd weer te geven.
- Druk op  om terug te gaan naar het hoofdscherm.

Wanneer het pictogram  wordt weergegeven op het hoofdscherm, werd een Timer Start of Timer Stop geprogrammeerd voor de STILLE modus.

4.6 Bluetooth-koppeling - Bediening op afstand

De warmtepomp is uitgerust met een Bluetooth-functie.

Dankzij de app “*EyesPool Inverter Connect*”, kan u uw smartphone gebruiken als afstandsbediening om uw warmtepomp te controleren binnen een bereik van 10 m in een vrij veld.

Om gebruik te maken van deze functie, moet u de volgende stappen volgen

Bluetooth:

- ▶ Download de gratis app “*EyesPool Inverter Connect*” op  of



- ▶ Maak een account aan in de applicatie.
- ▶ Volg de instructies in de video (onderstaande link) om uw smartphone te koppelen met de warmtepomp:
<https://www.hayward.fr/article/tutoriels-hayward/s-line-pro-bluetooth-appairage>



4. GEBRUIKERSINTERFACE (vervolg)

4.7 Selectie van de werkingsmodus

Verwarming - Automatisch - Afkoeling



Als de warmtepomp door de installateur is ingesteld in de modus Enkel Verwarmen of Enkel Afkoelen, is het niet mogelijk om de modus te wijzigen.

Druk op de knop  om de modus te wijzigen: Verwarming - Automatisch - Afkoeling.

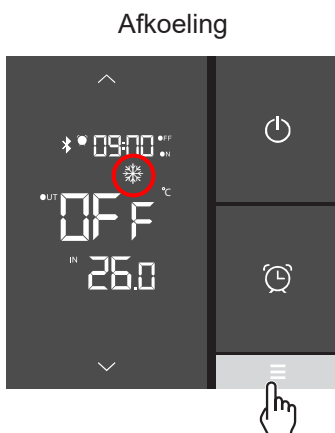
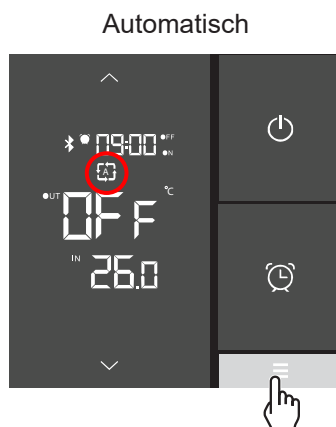
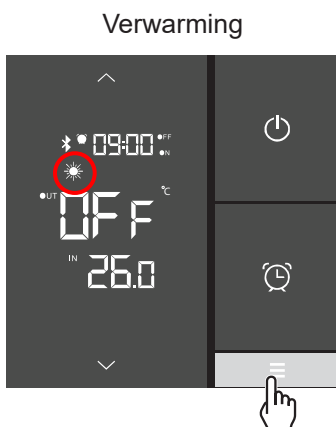





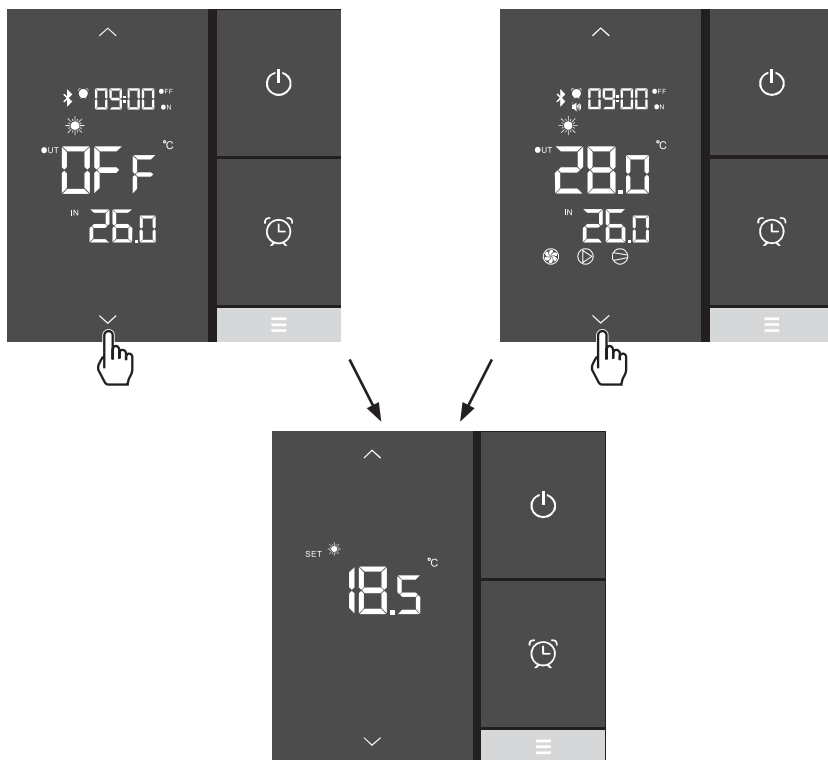

4. GEBRUIKERSINTERFACE (vervolg)

4.8 Instellen en visualiseren van de gewenste waarde

Gewenste watertemperatuur

U kan de gewenste waarde instellen in zowel de modus OFF als de modus ON, met een precisie van 0,5°C.



- Druk op  of  om de waarde te laten knipperen.
- Druk op  of  om de gewenste waarde te bepalen.
- Druk op  om te valideren of op  om te annuleren.

De instellingen worden automatisch opgeslagen als er binnen 5 seconden niet op een knop gedrukt wordt.







Het wordt aangeraden om nooit de 30°C te overschrijden om een vroegtijdige veroudering en verkleuring van de liners te voorkomen.

4. GEBRUIKERSINTERFACE (vervolg)

4.9 Het touchscreen vergrendelen en ontgrendelen

U kan het touchscreen vergrendelen of ontgrendelen in de modus ON of de modus OFF.

- Druk gedurende 5 seconden op  tot het pictogram verschijnt .
- Om het touchscreen te ontgrendelen, druk op  tot het pictogram  verdwijnt.

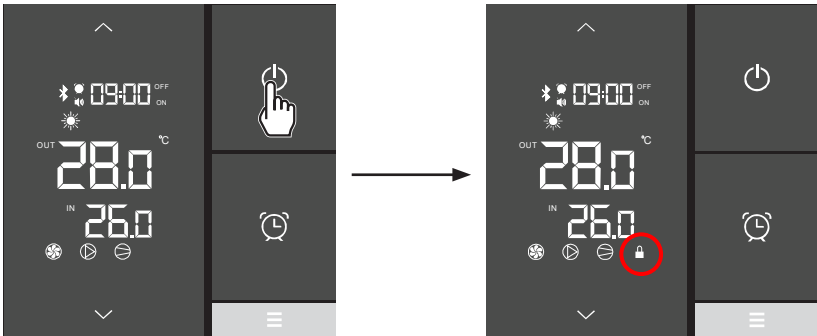

5. ONDERHOUD EN OVERWINTERING

5.1 Onderhoud

1 keer per jaar moeten er onderhoudswerken plaatsvinden om de levensduur en een goede werking van de warmtepomp te kunnen garanderen.

- Poets de verdamper met een zachte borstel, een luchtstraal of met water (**Opgelet, gebruik nooit een hogedrukreiniger**).
- Controleer of de condensaten goed afgevoerd worden.
- Controleer of de elektrische en hydraulische aansluitingen goed afsluiten.
- Controleer de hydraulische dichting van de condensor.
- De waterdichtheid van het koelcircuit **door een erkende professional** laten controleren met een lekdetector.



Voor ieder onderhoud moet de warmtepomp ontkoppeld worden van elke elektrische bron. Onderhoud mag enkel door een gekwalificeerde en bevoegde installateur gebeuren die gewend is met koelmiddelen om te gaan.

5.2 Overwintering

- Zet de warmtepomp in Modus "OFF".
- Ontkoppel de voeding van de warmtepomp.
- Maak de condensor leeg met behulp van de aflatopening om schade te vermijden. (belangrijk risico bij bevroering).
- Sluit de "by-pass"-klep af en schroef de aansluitingen op de in-/uitlaat los.
- Voer het resterende water in de condensor door middel van een luchtpistool af.
- Sluit de watertoevoer en -afvoer van de warmtepomp af om te vermijden dat vreemde voorwerpen binnendringen.
- Bedek de warmtepomp met de meegeleverde overwinteringshoes.



Eender welke schade veroorzaakt door een slechte overwintering, zorgt ervoor dat de garantie geannuleerd wordt.

6. BIJLAGEN

6.1 Elektrische schema's

HP5081DT3LVM / HP5111DT3LV

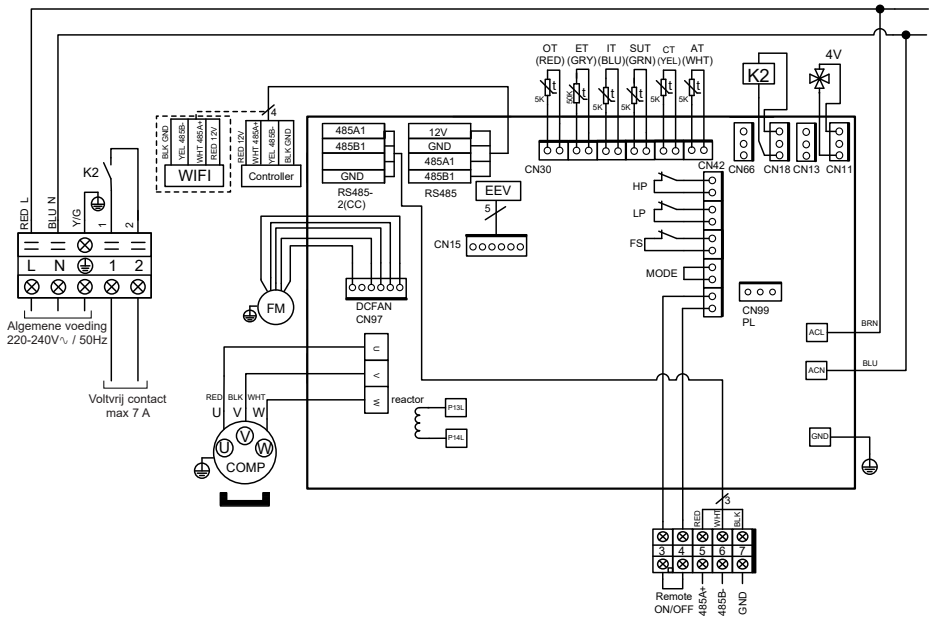

OPMERKINGEN

AT : LUCHTTEMPERATUURSSENSOR

COMP : COMPRESSOR

CT : CONDENSATIETEMPERatuur SENSOR

EEV : ELEKTRONISCHE DRUKREGELAAR

FM : VENTILATORMOTORR

FS : WATERDETECTOR

HP : HOGEDRUKSCHAKELAAR

IT : TEMPERATUURSSENSOR VOOR BINNENKOMEND WATER

LP : LAGEDRUKSCHAKELAAR

OT : TEMPERATUURSSENSOR VOOR BUITENGAAND WATER

SUT : AANZUIGTEMPERATUURSSENSOR

4V : 4-WEGSKRAAN

K2 : VOLTURIJ CONTACT MAX 7 A

ET : TEMPERATUURSSENSOR OPSTUWING

----- : OPTIONEEL

6. BIJLAGEN (vervolg)

6.2 Aansluitingen prioriteit verwarming eenfasepomp

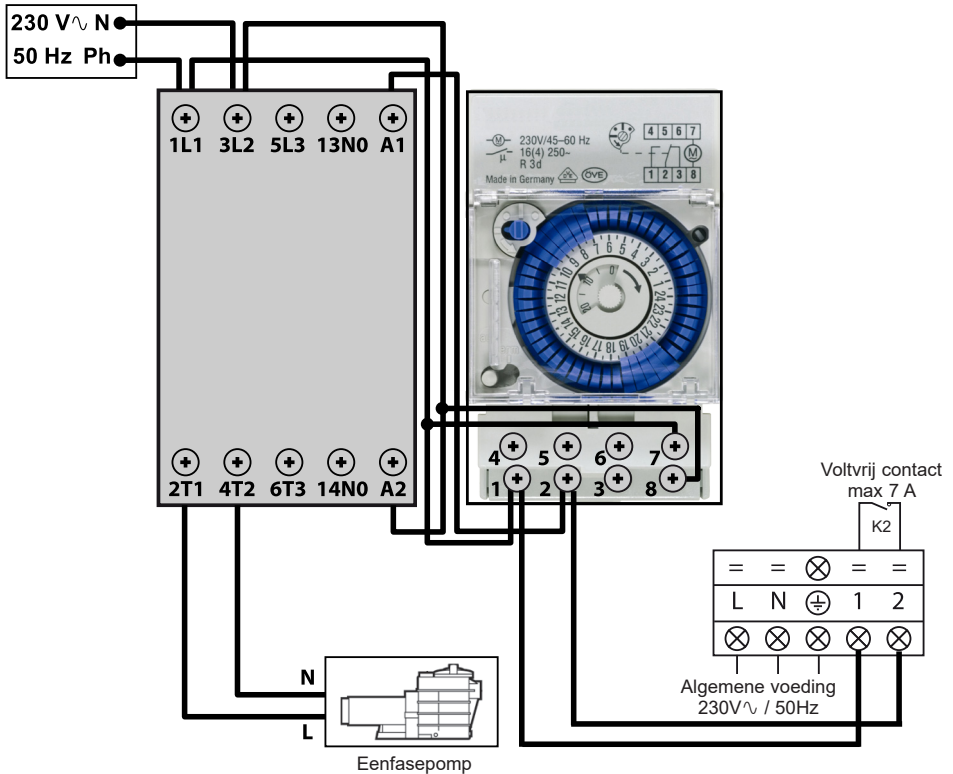

De zuilen 1-2 leveren een spanningvrij contact, zonder polariteit 230 V \sim / 50 Hz.

Sluit de zuilen 1 en 2 met kabels aan zoals op het schema hierboven is aangegeven zodat de werking van de filterpomp wordt ingesteld op een cyclus van 2 minuten per uur als de temperatuur van het bassin lager is dan aanbevolen.



De voeding van de filterpomp nooit direct aansluiten op de zuilen 1 en 2.

6. BIJLAGEN (vervolg)

6.3 Opengewerkte tekeningen en onderdelen

HP5081DT3LV / HP5111DT3LV / HP5151DT3LV

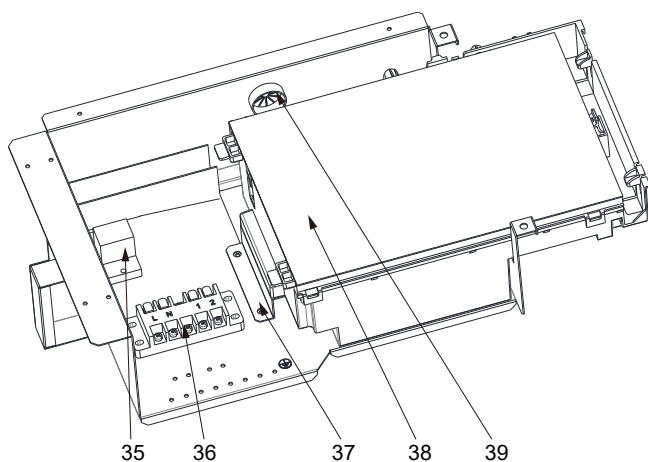
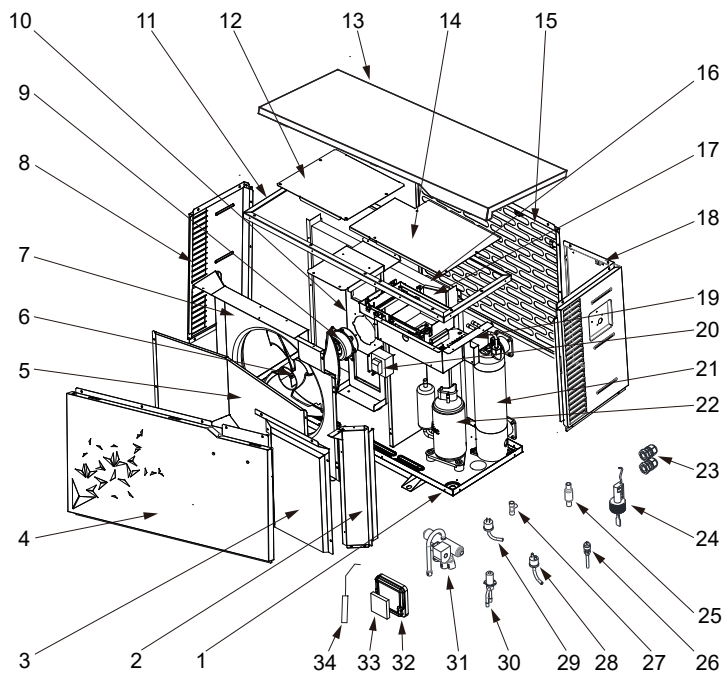

6. BIJLAGEN (vervolg)

Nr.	Omschrijving	Réf.	HP5081DT3LV	HP5111DT3LV	HP5151DT3LV
1	/	/	/	/	/
2	/	/	/	/	/
3	/	/	/	/	/
4	Paneel Voor	HWX80715842	✓	✓	n/a
		HWX80715857	n.v.t.	n.v.t.	✓
5	/	/	/	/	/
6	Ventilatorblad	HWX30103000006	✓	✓	n.v.t.
		HWX20000270004	n.v.t.	n.v.t.	✓
7	/	/	/	/	/
8	Linkerpaneel	HWX80713420	✓	✓	n.v.t.
		HWX80713423	n.v.t.	n.v.t.	✓
9	Motor ventilator DC	HWX80200018	✓	✓	n.v.t.
		HWX20000330132	n.v.t.	n.v.t.	✓
10	Motorsteun	HWX80708597	✓	✓	n.v.t.
		HWX80709977	n.v.t.	n.v.t.	✓
11	/	/	/	/	/
12	/	/	/	/	/
13	Paneel bovenaan	HWX80708601	✓	✓	n.v.t.
		HWX80709984	n.v.t.	n.v.t.	✓
14	/	/	/	/	/
15	Achterpaneel	HWX80710829	✓	✓	n.v.t.
		HWX80710966	n.v.t.	n.v.t.	✓
16	Verdamper met lamellen	HWX80600849	✓	n.v.t.	n.v.t.
		HWX80600781	n.v.t.	✓	n.v.t.
		HWX80600835	n.v.t.	n.v.t.	✓
17	/	/	/	/	/
18	Rechterpaneel	HWX80713421	✓	✓	n.v.t.
		HWX80713424	n.v.t.	n.v.t.	✓
19	/	/	/	/	/
20	Reactantie	HWX82500020	✓	✓	n.v.t.
		HWX82500021	n.v.t.	n.v.t.	✓
21	Titaancondensator/pvc	HWX80600939	✓	n.v.t.	n.v.t.
		HWX80600940	n.v.t.	✓	✓
		HWX80600096	n.v.t.	n.v.t.	✓
22	Compressor	HWX20000110448	✓	✓	n.v.t.
		HWX80100046	n.v.t.	n.v.t.	✓
23	Kabelwartel	HWX20012249	✓	✓	n.v.t.
		HWX20012238	n.v.t.	n.v.t.	✓
24	Detector waterdebiet	HWX83000068	✓	✓	✓
25	Filter Ø9.7-Ø9.7 (Ø19)	HWX20000140178	✓	✓	n.v.t.
	Filter Ø9.7-Ø9.7 (Ø28)	HWX20041444	n.v.t.	n.v.t.	✓
26	Drukafsluiter 40mm-1/2"	HWX20000140150	✓	✓	✓
27	T-schakelaar Ø9.52-2 xØ6.35(T) x 1.0	HWX30403000002	✓	✓	n.v.t.
	T-schakelaar Ø6.5-2 x Ø6.5(T) x 0.75	HWX20001460	n.v.t.	n.v.t.	✓
28	Drukregelaar lage druk NO 0.30MPa/0.15MPa	HWX20000360157	✓	✓	✓
29	Drukregelaar hoge druk NC 3.2MPa/4.4MPa	HWX20013605	✓	✓	✓
30	Elektronisch reduceerventiel	HWX81000011	✓	✓	n.v.t.
		HWX81000017	n.v.t.	n.v.t.	✓
31	4-wegskraan	HWX20041437	✓	✓	n.v.t.
		HWX20000140485	n.v.t.	n.v.t.	✓
32	Houder van de controller	HWX80901004	✓	✓	✓
33	Icd-controller Bluetooth	HWX72200312	✓	✓	✓

6. BIJLAGEN (vervolg)

HP5081DT3LV / HP5111DT3LV / HP5151DT3LV

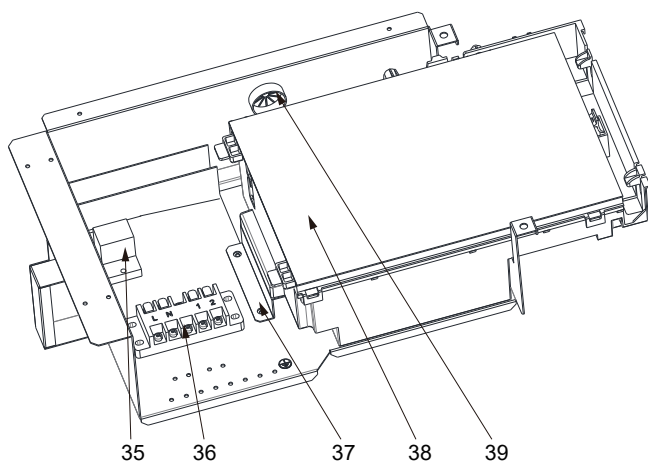
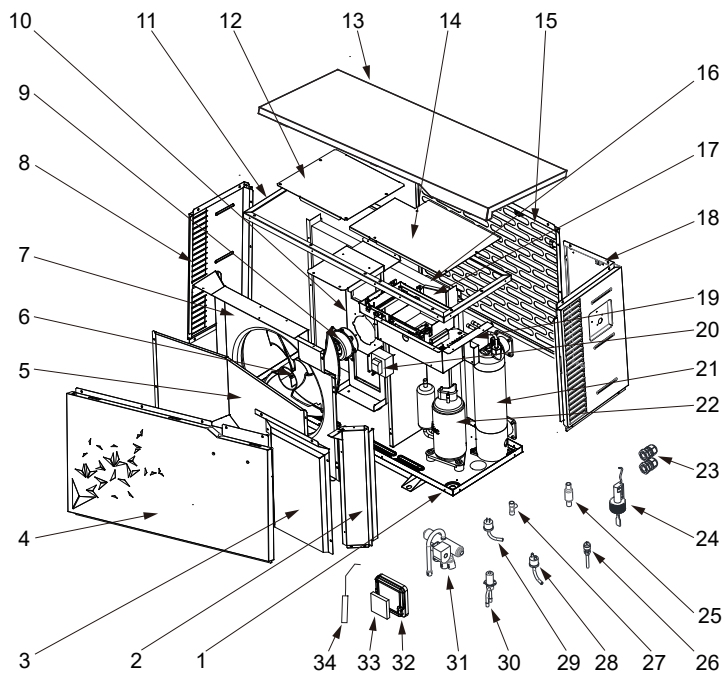

6. BIJLAGEN (vervolg)

Nr.	Omschrijving	Réf.	HP5081DT3LV	HP5111DT3LV	HP5151DT3LV
34	Waterafvoer sonde 5k-410mm	HWX83000050	✓	✓	✓
	Sensor voor binnenkomend water 5k-850mm	HWX83000052	✓	✓	✓
	Compressor ontleding sonde 50k-660mm	HWX83000026	✓	✓	✓
	Aspiratiesonde compressor 5k-560mm	HWX83000044	✓	✓	n.v.t.
	Aspiratiesonde compressor 5k-760mm	HWX83000053	n.v.t.	n.v.t.	✓
	Ontdooisensor 5k-680mm	HWX83000051	✓	✓	n.v.t.
	Ontdooisensor 5k-1040mm	HWX83000045	n.v.t.	n.v.t.	✓
	Luchttemperatuursonde 5k-350mm	HWX83000049	✓	✓	✓
35	Relais K2	HWX20000360297	✓	✓	✓
36	Aansluitblok L-N-GND -5 aansluitingen 4mm ²	HWX40003901	✓	✓	✓
37	/	/	/	/	/
38	Elektronische driver-kaart	HWX72200168SL08	✓	n.v.t.	n.v.t.
		HWX72200168SL11	n.v.t.	✓	n.v.t.
		HWX72200168SL15	n.v.t.	n.v.t.	✓
39	/	/	/	/	/

6. BIJLAGEN (vervolg)



6.4 Storingsgids

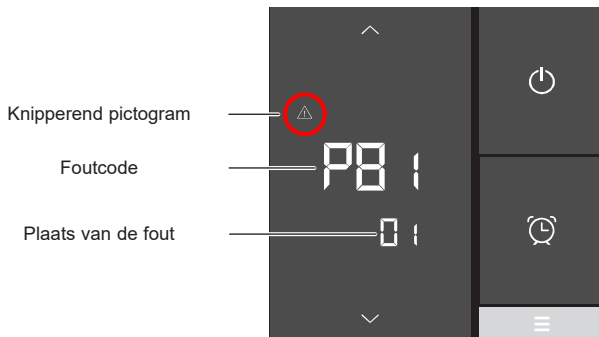

Bepaalde operaties moeten worden uitgevoerd door een erkende technicus.

In geval van een storing, worden de volgende indicaties op het scherm weergegeven:



In geval van fouten, drukt u op de knop  of  om de foutcodes te bekijken.

Zie het onderstaande overzicht.



Nadat het probleem is opgelost, wordt de fout automatisch afgewerkt, verdwijnt de driehoek.

6. BIJLAGEN (vervolg)

Probleem	Foutcodes	Beschrijving	Oplossing
Storing temperatuursonde wateraanvoer (IT)	P01	De sensor is open of heeft kortsluiting	De aansluiting op het verlengsnoer controleren of de sensor vervangen
Storing temperatuursonde waterafvoer (OT)	P02		
Storing sonde luchttemperatuur (AT)	P04		
Storing ontdooiingssonde (CT)	P05		
Storing aanzuigsonde Compressor (SUT)	P07		
Storing afvoersonde Compressor (ET)	P08		
Storing Overdruk	E01	De sensor is open of heeft kortsluiting	De aansluiting op het verlengsnoer controleren of de sensor vervangen
			Waterdebiet controleren
			Waterdebietdetector controleren
			Opening van de kleppen controleren
			Bypass controleren
			De verdamper op vervuiling controleren
			Te hoge watertemperatuur
			Probleem met niet-condenseerbare stoffen, verwijder vloeistof en lucht uit het koelcircuit
Te veel vloeistof aanwezig, verwijder de vloeistof in een fles			
Storing Onderdruk	E02	De sensor is open en heeft kortsluiting	De aansluiting op het verlengsnoer controleren of de sensor vervangen
			Groot koelvloeistoflek, met een detector het lek zoeken
			Te laag luchtdebiet, de rotatiesnelheid van de ventilator controleren
			De verdamper op vervuiling controleren, het oppervlak reinigen

6. BIJLAGEN (vervolg)

Probleem	Foutcodes	Beschrijving	Oplossing
Storing Debietmeter	E03	De sensor is open of heeft kortsluiting	De CN29/OVT-aansluiting op de kaart controleren of de sensor vervangen
			Te weinig water, de werking van de filterpomp controleren
			Opening van de stopkleppen controleren
			De instelling van de bypass controleren
Temperatuurverschil tussen Aanvoer/Afvoer > 13°C	E05	Alleen in Koude modus toepasbaar	Te weinig water, de werking van de filterpomp controleren
			Opening van de stopkleppen controleren
			De instelling van de bypass controleren
Vorstbescherming	E07	Temperatuur waterafvoer < 4°C	De warmtepomp stoppen, de condensor leegmaken, risico op bevriezing
Communicatieprobleem	E08	Geen communicatie tussen de elektronische kaart en de gebruikersinterface	De aansluitingen controleren - zie elektrisch schema
Vorstbescherming van niveau 1	E19	2°C < Watertemperatuur < 4°C en Luchttemperatuur < 0°C	Schakel de warmtepomp uit, maak de condensor leeg om bevriezing te voorkomen, de pomp start standaard de filterpomp om bevriezing te voorkomen
Vorstbescherming van niveau 2	E29	Watertemperatuur < 2°C en Luchttemperatuur < 0°C	Schakel de warmtepomp uit, maak de condensor leeg om bevriezing te voorkomen, de pomp start standaard de filterpomp en de warmtepomp om bevriezing te voorkomen.
Storing ventilatormotor	F03 I	Motor geblokkeerd of storing met de verbinding	De vrije rotatie controleren, de CN97/DCFan-aansluiting controleren; de motor vervangen
Storing ventilatormotor	F05 I	Storing verbinding	Controleer de DCFAN/CN97-aansluiting; de motor vervangen
Te lage buitentemperatuur	EP	Uiterste bedrijfstemperatuur bereikt	De warmtepomp stoppen
De warmtepomp start niet langer op	- - - OFF	Contact (5-6) Remote On/Off Open	Het contact (5-6) sluiten Remote On/Off (zie elektrisch schema)

6. BIJLAGEN (vervolg)

6.5 Garantie

GARANTIEVOORWAARDEN

Alle HAYWARD-producten vallen onder garantie in geval van fabrieks- of materiaalfouten gedurende twee jaar vanaf de aankoopdatum. Elke garantieaanvraag moet samen met een aankoopbewijs met datum ingediend worden. Wij dringen er dus op aan dat u uw factuur bewaart. De HAYWARD-garantie is beperkt tot reparatie of vervanging, bepaald door HAYWARD, van de defecte toestellen zolang ze op een normale wijze en volgens de voorschriften die in de handleiding vermeld, gebruikt zijn, het apparaat niet aangepast is en enkel gebruikt is in met HAYWARD componenten en onderdelen. Schade veroorzaakt door vrieskou en chemische agensen vallen niet onder garantie. Alle andere kosten (transport, werkuren...) worden niet door de garantie gedekt.

HAYWARD kan niet verantwoordelijk gesteld worden voor eender welke directe of indirecte schade veroorzaakt tijdens de installatie, aansluiting of onjuist gebruik van een product.

Om een garantie aan te vragen en herstel of vervanging van een product te eisen, moet u zich tot uw verdeler wenden. Wij zullen geen enkele retour naar de fabriek aanvaarden zonder een vooraf bekomen schriftelijke goedkeuring. Slijtage valt niet onder garantie.

Opzettelijk leeg gelaten pagina



S.Line Pro *Fi*

UNITÀ DI RISCALDAMENTO A POMPA DI CALORE PER PISCINE



Manuale d'Uso e di Installazione

INDICE

1. INTRODUZIONE	1
2. SPECIFICHE TECNICHE	4
2.1 Dati tecnici della pompa a calore	4
2.2 Soglie di funzionamento	5
2.3 Dimensioni	6
3. INSTALLAZIONE E COLLEGAMENTO	7
3.1 Schema di principio	7
3.2 Pompa di calore	7
3.3 Collegamento idraulico	8
3.4 Collegamento Elettrico	9
3.5 Primo avviamento	10
4. INTERFACCIA UTENTE	12
4.1 Presentazione generale	12
4.2 Regolazione della portata d'acqua	14
4.3 Impostazione dell'orologio	15
4.4 Configurazione Timer ON/OFF	15
4.5 Regolazione della funzione Timer in modalità SILENZIOSO	17
4.6 Associazione Bluetooth - Comando a distanza	18
4.7 Selezione della modalità di funzionamento	19
4.8 Regolazione e visualizzazione del set point	20
4.9 Blocco e sblocco del touch screen	21
5. MANUTENZIONE E SVERNAMENTO	22
5.1 Manutenzione	22
5.2 Svernamento	22
6. APPENDICI	23
6.1 Schemi Elettrici	23
6.2 Collegamenti priorità riscaldamento pompa monofase	25
6.3 Esplosi e parti di ricambio	26
6.4 Risoluzione dei problemi	30
6.5 Garanzia	33

Leggere attentamente e riporre in luogo facilmente accessibile per la consultazione.

La presente documentazione deve essere consegnata al proprietario della piscina, il quale dovrà conservarla in un luogo sicuro.

1. INTRODUZIONE

Vi ringraziamo per aver acquistato la nostra pompa a calore per piscina Hayward. La pompa a calore S.LINE PRO è stata appositamente studiata secondo severe norme di fabbricazione, allo scopo di fornire il più elevato livello di qualità possibile.

Le pompe a calore S.LINE PRO vi offriranno eccezionali prestazioni durante tutta la stagione dei bagni adattando la potenza, i consumi elettrici ed il livello acustico alle esigenze di riscaldamento della vostra piscina, grazie al circuito logico di controllo FULL INVERTER.



Leggere attentamente le istruzioni contenute in questo manuale prima dell'uso

Le pompe a calore S.LINE PRO sono esclusivamente destinate al riscaldamento dell'acqua della piscina. Non vanno usate per altri scopi.

Il presente manuale contiene tutte le informazioni necessarie riguardo all'installazione, alla risoluzione delle anomalie e alla manutenzione della pompa.

Leggere attentamente il manuale prima di aprire la pompa o di effettuare operazioni di manutenzione sulla stessa. Il costruttore della pompa non sarà ritenuto in alcun caso responsabile di eventuali danni fisici subiti da un utente o di eventuali danni subiti dal materiale in seguito ad errori d'installazione, a tentativi di risoluzione di anomalie o ad interventi di manutenzione inutili. Vanno sempre rispettate le istruzioni contenute nel manuale

Il mancato rispetto delle istruzioni annulla la garanzia.

INTRODUZIONE (segue)



Istruzioni di sicurezza



Questo apparecchio contiene R32.

Non usare mai un refrigerante diverso dall'R32. La miscela di altri corpi gassosi con l'R32 rischia di provocare pressioni anormalmente elevate che possono causare guasti o rotture dei tubi e danni fisici alle persone

Durante le operazioni di riparazione o manutenzione, utilizzare tubi di rame conformi alla Norma EN 12375-1 (maggio 2020) e alla Direttiva Europea per Apparecchiature in Pressione 97/23 / CE.

La pompa a calore è sotto pressione: occorre, pertanto, evitare, in qualunque caso, di forare i tubi o di effettuare giunzioni brasate. Rischio di esplosione.

Non esporre l'apparecchio alle fiamme, alle scintille o ad altre sorgenti di combustione. La pompa potrebbe esplodere provocando ferite gravi o addirittura mortali.



La pompa a calore va installata esclusivamente all'esterno degli edifici.

- Quando non viene usata, la pompa a calore va riposta in un locale sufficientemente ventilato, dotato di una superficie al suolo di A_{\min} (m²) calcolata secondo la seguente formula : $A_{\min} = (M / (2.5 \times 0.22759 \times h_0))^2$
M corrisponde alla carica di refrigerante in kg contenuta nell'apparecchio, mentre h₀ corrisponde all'altezza di stoccaggio. Se la pompa viene riposta a livello del suolo h₀ = 0,6 m.
- L'impianto va installato unicamente da personale qualificato.
- Non installare la pompa a calore su un supporto suscettibile di amplificare le vibrazioni prodotte dalla stessa.
- Verificare che le dimensioni del supporto previsto per l'impianto siano adeguate rispetto al peso dell'apparecchiatura
- Non installare la pompa in un luogo suscettibile di amplificarne il livello acustico o in cui il rumore prodotto dall'impianto rischi di disturbare i vicini.
- L'allacciamento elettrico va effettuato da un elettricista qualificato, secondo le norme vigenti nel paese in cui è installata la pompa cfr. § 3.4.
- Staccare l'alimentazione principale e il sezionatore prima di effettuare qualunque intervento. Qualunque distrazione può causare un'elettrocuzione.
- Prima di procedere all'installazione, verificare che il cavo di terra non sia tagliato o scollegato.

INTRODUZIONE (segue)

- Collegare e serrare correttamente il cavo d'alimentazione elettrica. Un collegamento non correttamente effettuato può danneggiare i componenti elettrici.
- L'esposizione della pompa a calore all'acqua o all'umidità può provocare un'elettrocuzione. State molto attenti.
- Se riscontrate un difetto o un'anomalia, non installate la pompa e chiamate immediatamente il rivenditore.
- La manutenzione e le diverse operazioni vanno effettuate con la frequenza e nei momenti consigliati dal manuale.
- Le riparazioni vanno effettuate da personale qualificato.
- Usare solo pezzi di ricambio originali.
- Non usare metodi di pulizia diversi da quello consigliato nel manuale.

Avvertenze importanti riguardo al refrigerante utilizzato

Questo prodotto contiene gas serra fluorurati regolamentati dal protocollo di Kyoto. Non sprigionare questo gas nell'atmosfera.

Tipo di refrigerante: R32

Valore GWP(1): 675, valore basato sulla quarta relazione del GIEC.

La quantità di refrigerante basata sulla regolamento n. 517/ 2014 (F-Gas) è indicata sulla piastrina segnaletica dell'apparecchiatura

La vigente normativa europea o locale potrà esigere ispezioni periodiche delle perdite/fughe. Per maggiori informazioni in merito, contattare il distributore locale.

(1) Potenziale di riscaldamento globale

2. SPECIFICHE TECNICHE

2.1 Dati tecnici della pompa a calore

Modelli	S.LINE PRO	HP5081DT3LV	HP5111DT3LV	HP5151DT3LV
Tensione di alimentazione	V	220V-240V \surd / 1fase/ 50Hz		
Refrigerante	/	R32		
Carica	kg	0,430	0,450	0,60
Massa in tCO ₂ e	/	0,29	0,30	0,41
Frequenza di controllo delle perdite	/	Non obbligatoria, ma consigliata una volta all'anno		
Capacità di riscaldamento Min--Max ^(a)	kW	2,83 -- 8,16	1,95 -- 10,90	5,27 -- 15,66
Potenza elettrica assorbita Min--Max ^(a)	kW	0,212 -- 1,19	0,150 -- 1,92	0,457 -- 2,80
Corrente nominale di esercizio Min--Max ^(a)	A	1,41 -- 5,20	1,05 -- 8,49	2,04 -- 12,28
COP Max--Min ^(a)	/	13,30 -- 6,81	12,92 -- 5,67	11,53 -- 5,59
Capacità di riscaldamento Min--Max ^(b)	kW	1,77 -- 5,91	1,86 -- 8,40	3,81 -- 11,67
Potenza elettrica assorbita Min--Max ^(b)	kW	0,31 -- 1,28	0,30 -- 1,83	0,588 -- 2,71
COP Max--Min ^(b)	/	5,70 -- 4,62	6,20 -- 4,59	6,48 -- 4,31
Corrente nominale ammissibile (CMS)	A	6,50	10,30	14
Calibro del fusibile	gG	10	12	16
Interruttore curva C	C	10	12	16
Corrente di avviamento	A	< CMS		
Allacciamento idraulico	mm	50 mm		
Portata idrica nominale ^(a)	m ³ /h	3,50	4,60	6,70
Perdita di carica sull'acqua max	kPa	8	5	10
Compressore	/	DC Inverter MITSUBISHI ELECTRIC		DC Inverter Mitsubishi
Tipo	/	Double Rotatif		Double Rotatif
Quantità	/	1		
Resistenza di avvolgimento a 20°C	Ohm	1,91 +/- 5%		0,95 +/- 5%
Ventilatore	/	Assiale		
Quantità	/	1		
Diametro	mm	405		500
Numero di pale	/	3		
Motore	/	DC Inverter		
Quantità	/	1		
Velocità di rotazione	giri/min.	500 -- 800	500 -- 900	500 -- 750
Velocità modalità silenziosa	giri/min.	500	500	500
Livello di pressione acustica a 1 metro	dB(A)	45,1	48,6	54,1
Livello di pressione acustica a 10 metri	dB(A)	27,9	31,6	36,9
Dimensioni nette dell'unità (L-I-H)	mm	1011 / 430 / 622		1025 / 480 / 768
Peso	kg	61	61	87



(a) Aria asciutta 27°C – Umidità relativa 78% - Temperatura d'ingresso dell'acqua 26°C.

(b) Aria asciutta 15°C - Umidità relativa 71% - Temperatura d'ingresso dell'acqua 26°C.

2. SPECIFICHE TECNICHE (segue)

2.2 Soglie di funzionamento

Per assicurare un funzionamento sicuro ed efficiente, utilizzare la pompa di calore entro le seguenti soglie di temperatura e umidità.

	Modalità riscaldamento 	Modalità Raffreddamento 
Temperatura esterna	-7°C – +35°C	+7°C – +43°C
Temperatura acqua	+12°C – +32°C	+8°C – +40°C
Umidità relativa	< 80%	< 80%
Soglia di configurazione set point	+15°C – +32°C	+8°C – +32°C



Se la temperatura o l'umidità non soddisfano le suddette condizioni, è possibile che si verifichi l'intervento di dispositivi di sicurezza che impediscano alla pompa di calore di azionarsi.



Per evitare eventuali rischi di deterioramento dei liner la temperatura massima di riscaldamento è limitata a 32°C. Hayward declina ogni responsabilità in caso di uso a temperature superiori a +32°C.

2. SPECIFICHE TECNICHE (segue)

2.3 Dimensioni

Modelli:

HP5081DT3LV / HP5111DT3LV / HP5151DT3LV

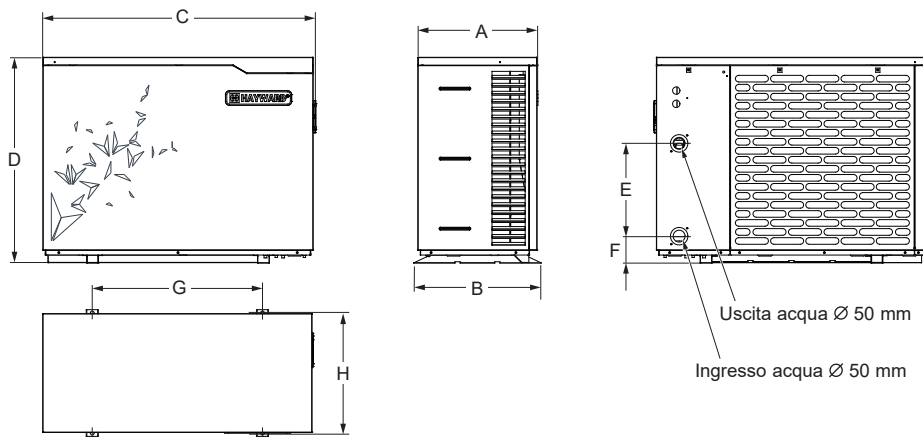

Unità : mm

Modella Numerazione	HP5081DT3LV / HP5111DT3LV	HP5151DT3LV
A	393	453
B	430	480
C	1011	1030
D	621,5	776
E	350	350
F	97,5	102
G	625	645
H	406	456

3. INSTALLAZIONE E COLLEGAMENTO

3.1 Schema di principio

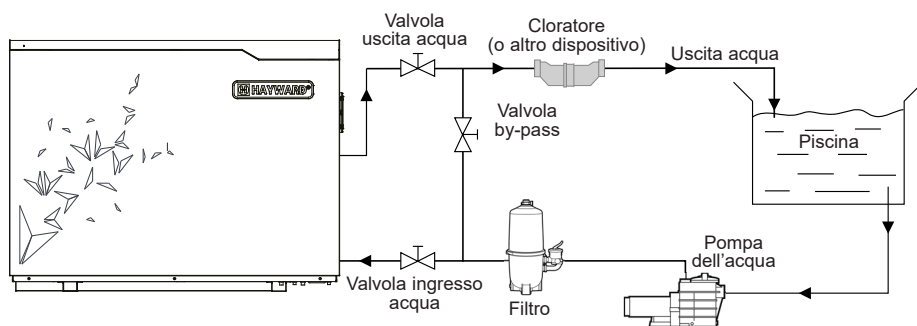

N.B.: L'unità fornita è priva di dispositivi di trattamento o di filtraggio. Gli elementi rappresentati nello schema devono essere forniti dall'installatore.

3.2 Pompa di calore



Installare l'Unità di Riscaldamento a Pompa di Calore per Piscine all'esterno e al di fuori di locali tecnici chiusi.

Installare l'unità in luogo riparato e rispettare le distanze minime sottoindicate, al fine di evitare il rischio di ricircolo dell'aria o eventuali diminuzioni delle prestazioni complessive dell'unità stessa.

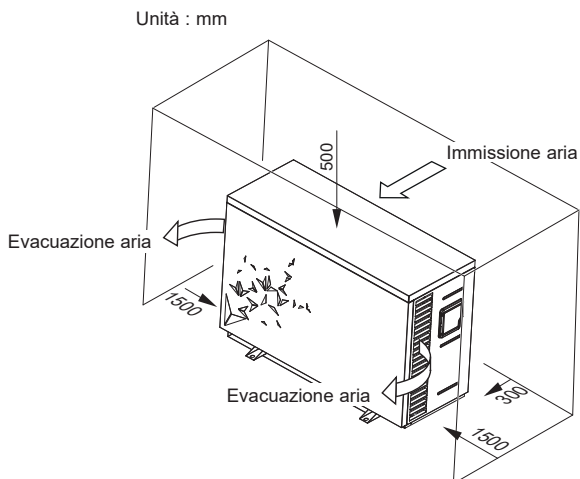

3. INSTALLAZIONE E COLLEGAMENTO (segue)



Preferibilmente, installare l'Unità di Riscaldamento a Pompa di calore su soletta in calcestruzzo alleggerito o su apposito supporto in metallo e montare l'unità sui silentblock in dotazione (bulloneria e rondelle non fornite).

Distanza max. tra l'unità e la piscina: 15 metri.

Lunghezza totale andata/ritorno tubazioni idrauliche: 30 metri.

Isolare le tubazioni idrauliche sia interrate che non interrate.

La pompa di calore deve essere installata a una distanza minima dalla vasca conforme alla norma NF C 15-100 (ossia, per la Francia, a 3,5 m dallo specchio d'acqua) o conforme alle norme relative all'installazione vigenti negli altri paesi.

Non installare la pompa di calore in prossimità di fonti di calore.

In caso d'installazione in regioni nevose, si consiglia di proteggere la macchina per prevenire un eventuale accumulo di neve sull'evaporatore.

3.3 Collegamento idraulico

L'unità è dotata di due raccordi di unione del diametro di 50 mm. Utilizzare tubi in PVC per tubazioni idrauliche Ø 50 mm. Collegare la tubazione per l'ingresso dell'acqua dell'unità alla conduttura proveniente dal gruppo di filtraggio, quindi collegare la tubazione per lo scarico dell'acqua alla conduttura utilizzata per immettere acqua nella piscina (cf. schema seguente).

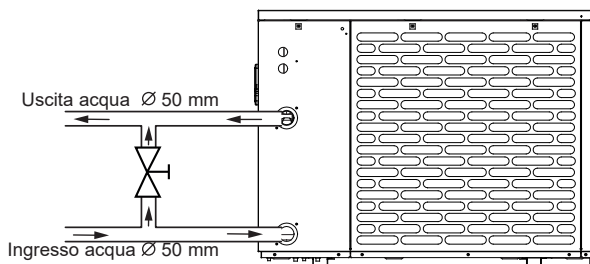

Installare una valvola by-pass tra l'ingresso e l'uscita dell'unità.



Se si utilizza un cloratore o un cloratore automatico, installare tale dispositivo dopo l'unità, al fine di proteggere il condensatore in Titanio da una concentrazione troppo elevata di prodotto chimico.



Per facilitare il drenaggio dell'unità durante la preparazione all'inverno e fornire facile accesso alle operazioni di smontaggio e manutenzione, si consiglia di installare la valvola by-pass e i raccordi di unione in dotazione in corrispondenza dell'ingresso e dell'uscita dell'unità.

3. INSTALLAZIONE E COLLEGAMENTO (segue)

3.4 Collegamento Elettrico



L'installazione elettrica e il cablaggio del presente dispositivo devono essere conformi alle norme d'installazione locali vigenti.

F	NF C15-100	GB	BS7671:1992
D	DIN VDE 0100-702	EW	EVHS-HD 384-7-702
A	ÖVE 8001-4-702	H	MSZ 2364-702/1994/MSZ 10-553 1/1990
E	UNE 20460-7-702 1993, RECBT ITC-BT-31 2002	M	MSA HD 384-7-702.S2
IRL	Wiring Rules + IS HD 384-7-702	PL	PN-IEC 60364-7-702:1999
I	CEI 64-8/7	CZ	CSN 33 2000 7-702
LUX	384-7.702 S2	SK	STN 33 2000-7-702
NL	NEN 1010-7-702	SLO	SIST HD 384-7-702.S2
P	RSIUEE	TR	TS IEC 60364-7-702



Assicurarsi che l'alimentazione elettrica disponibile e la frequenza di rete siano adeguate alla corrente operativa richiesta, tenendo in considerazione l'area di collocazione dell'unità e la corrente necessaria ad alimentare ogni altro dispositivo collegato allo stesso circuito.

HP5081DT3LV / HP5111DT3LV / HP5151DT3LV
230V ~ +/- 10 % 50 Hz 1 Fase

Fare riferimento allo schema dell'impianto elettrico corrispondente in appendice.

Tre connessioni sono destinate all'alimentazione elettrica e due al comando della pompa di filtraggio (Asservimento).

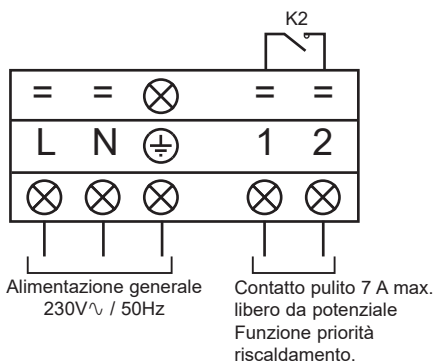

3. INSTALLAZIONE E COLLEGAMENTO (segue)



La linea di alimentazione elettrica deve essere opportunamente provvista di salvamotore tipo alimentazione motore (gG) o di interruttore curva C e interruttore differenziale 30mA (v. tabella seguente).

Modelli		HP5081DT3LV	HP5111DT3LV	HP5151DT3LV
Alimentazione elettrica	V/Ph/ Hz	230V~ 50Hz	230V~ 50Hz	230V~ 50Hz
Calibro fusibile tipo gG	A	10 gG	12 gG	16 gG
Interruttore curva C	A	10 C	12 C	16 C
Sezione cavo	mm ²	3G 2,5	3G 2,5	3G 2,5



Utilizzare un cavo di alimentazione tipo RO 2V / R 2V o equivalente.



Le sezioni del cavo sono fornite per una lunghezza massima di 25 m, ma devono comunque essere controllate e adattate a seconda delle condizioni d'installazione.



Staccare sempre l'alimentazione principale prima di aprire la scatola elettrica.

3.5 Primo avviamento

Procedura di avviamento - dopo aver completato l'installazione, attenersi alla seguente procedura:

- 1) Ruotare manualmente i ventilatori per verificarne la libertà di movimento e per assicurarsi che l'elica sia correttamente fissata all'albero motore.
- 2) Assicurarsi che l'unità sia correttamente collegata alla fonte di alimentazione principale (v. schema dell'impianto elettrico in appendice).
- 3) Attivare la pompa di filtraggio.
- 4) Verificare che tutte le valvole dell'acqua siano aperte e che l'acqua fluisca nell'unità prima di avviare qualsiasi processo di riscaldamento o raffreddamento.
- 5) Verificare che la manichetta per lo scarico della condensa sia correttamente collegata e che non vi sia ostacolo al suo funzionamento.
- 6) Attivare l'alimentazione elettrica destinata all'unità, quindi premere il pulsante ON/OFF  sul pannello di controllo.

3. INSTALLAZIONE E COLLEGAMENTO (segue)

- 7) Verificare che non vengano visualizzati i simboli indicanti un allarme o un blocco. Qualora venissero visualizzati tali simboli, consultare l'apposito manuale (v. § 6.4).
- 8) Definire la portata dell'acqua agendo sulla valvola by-pass (v. § 2.1 e 4.2) secondo le indicazioni riportate sulla targhetta identificativa del modello, fino a ottenere una differenza nella temperatura dell'acqua in Ingresso/ Uscita di 2°C.
- 9) Dopo alcuni minuti di utilizzo, assicurarsi che l'aria in uscita sia più fredda (5°C-10°C).
- 10) Ad unità avviata, spegnere la pompa di filtraggio. L'unità si spegne automaticamente e viene visualizzato il codice errore E03 (v. § 6.4).
- 11) Lasciare l'unità e la pompa piscina in funzione per 24 ore al giorno fino a quando l'acqua non raggiunge la temperatura desiderata. Quando la temperatura dell'acqua in ingresso raggiunge il valore predefinito, l'unità si spegne. L'unità si riavvia automaticamente (fino a quando la pompa della piscina rimane in funzione) quando la temperatura dell'acqua scende di 0,5°C rispetto alla temperatura impostata.

Interruttore di portata - L'unità è dotata di un interruttore di portata che ne regola l'accensione, quando la pompa di filtraggio della piscina è in funzione, e lo spegnimento, quando la pompa di filtraggio della piscina è fuori servizio. Se il livello dell'acqua è troppo basso, il codice d'allarme E03 viene visualizzato sul regolatore (v. § 6.4).

Temporizzazione - L'unità è dotata di un dispositivo di temporizzazione con ritardo di 3 minuti atto a proteggere i componenti del circuito di controllo e a prevenire avvii intempestivi e interferenze concernenti il contattore. Questa funzione riavvia automaticamente l'unità circa 3 minuti dopo ogni interruzione del circuito di controllo. Tale dispositivo si attiva anche in seguito a una breve interruzione di corrente.

4. INTERFACCIA UTENTE

4.1 Presentazione generale

L'unità è dotata di un pannello di comando digitale touch screen collegato elettricamente e preimpostato in fabbrica in modalità riscaldamento.

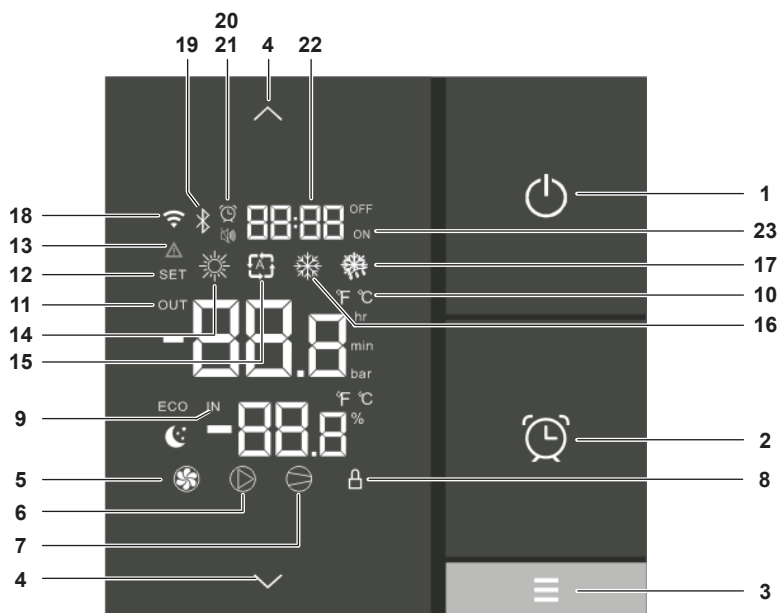

Legenda

1		ON/OFF/Annulla
2		Impostazione Ora e Timer
3		Selezione della modalità di funzionamento
4		Scorrimento su / giù +°C / -°C
5		Ventola ON
6		Contatto pulito OUT2 ON
7		Compressore ON
8		Schermo bloccato
9		Ingresso acqua
10		Celsius / Fahrenheit
11		Uscita acqua
12		Impostazioni avanzate

13		Errore sistema
14		Modalità riscaldamento
15		Modalità auto
16		Modalità raffreddamento
17		Modalità sbrinamento
18		N/D
19		Connessione Bluetooth
20		Timer programmato
21		Spia modalità silenzioso / Timer
22		Ora / Ora timer
23		Timer programmati in OFF e ON

4. INTERFACCIA UTENTE (segue)

Modalità OFF/SPENTO

Quando l'unità è in stand-by (Modalità OFF), sul display del regolatore viene visualizzata la dicitura "OFF" e, dopo un minuto, lo schermo passa alla modalità di risparmio energetico.

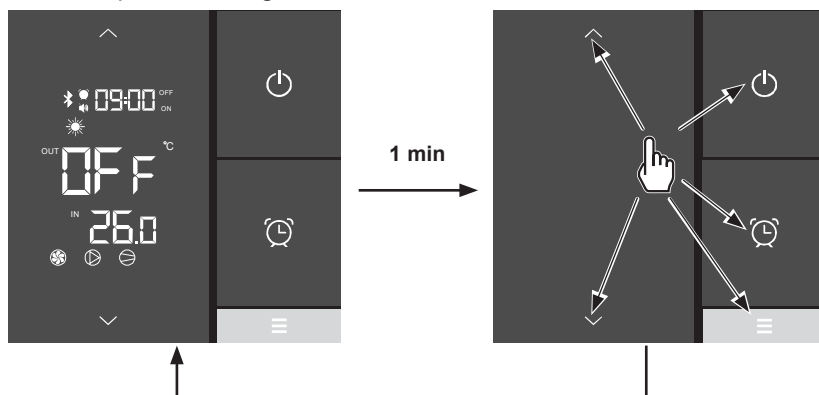

Per tornare alla visualizzazione completa, è sufficiente premere un pulsante qualsiasi.

Modalità ON

Quando l'unità è in funzione o in fase di impostazione (Modalità ON), viene visualizzata sullo schermo del regolatore la temperatura dell'acqua in ingresso e in uscita e, dopo un minuto, lo schermo passa alla modalità di risparmio energetico.

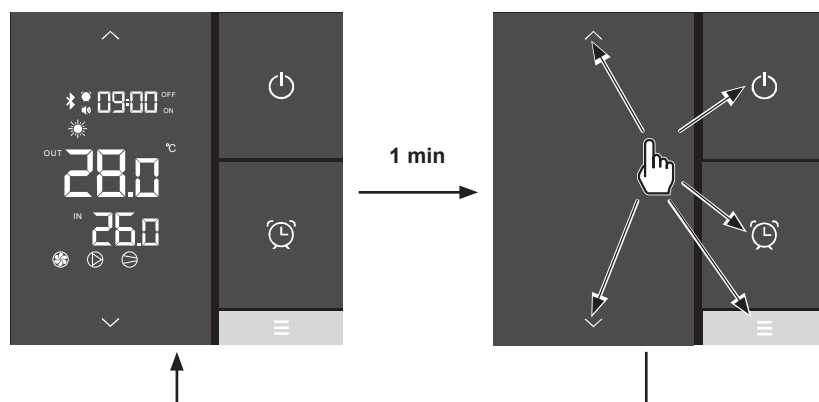

Per tornare alla visualizzazione completa, è sufficiente premere un pulsante qualsiasi.

4. INTERFACCIA UTENTE (segue)

4.2 Regolazione della portata d'acqua

Tenendo aperte le valvole, regolare la valvola by-pass in modo tale da ottenere una differenza di 2°C tra la temperatura dell'acqua in ingresso e la temperatura dell'acqua in uscita (v. schema di principio § 3.1).

È possibile controllare le impostazioni visualizzando le temperature dell'acqua in ingresso e in uscita direttamente sul pannello di comando, attenendosi alla procedura indicata di seguito.



Per impostare la valvola by-pass in modo da ottenere una differenza di 2°C tra ingresso e uscita.

Premere  per uscire dal menu.

- L'apertura della valvola "by-pass" genera una portata di minore entità nello scambiatore della pompa di calore, che provoca un aumento della differenza tra la temperatura dell'acqua in entrata e quella dell'acqua in uscita.
- La chiusura della valvola "by-pass" genera una portata di maggiore entità nello scambiatore della pompa di calore, che provoca una riduzione della differenza tra la temperatura dell'acqua in entrata e quella dell'acqua in uscita.

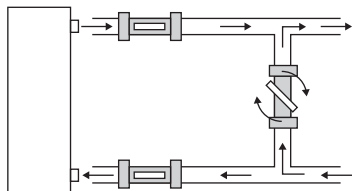









Le impostazioni correnti possono essere controllate visualizzando la temperatura dell'acqua in entrata e in uscita (1-2) direttamente tramite l'app "EyesPool Inverter Connect" (v. § 4.6).



4. INTERFACCIA UTENTE (segue)

4.3 Impostazione dell'orologio

Dopo aver definito le varie impostazioni, premere  per confermare. Se non viene premuto nessun pulsante, la configurazione è salvata automaticamente dopo 5 secondi.













- Premere , l'ora lampeggia.
- Premere , le ore lampeggiano. Impostare le ore con i pulsanti  e .
- Premere  e impostare i minuti con  e .
- Confermare con .

4.4 Configurazione Timer ON/OFF

La configurazione di questa funzione è necessaria se si desidera azionare l'unità per un periodo più breve rispetto a quello impostato tramite l'orologio che regola l'azionamento della pompa di filtraggio. La funzione permette quindi di programmare una partenza ritardata e/o un arresto anticipato o, semplicemente, di vietare il funzionamento in una determinata fascia oraria (ad esempio, di notte).

È possibile programmare un Timer Start (ON) e un Timer Stop (OFF).

Programmazione Timer- Start (ON)

- Tenere premuto  per 2 secondi, fino a quando l'icona  non inizia a lampeggiare.
- Premere ,  lampeggia ().
- Premere  e impostare le ore con  e .
- Premere  e impostare i minuti con  e .
- Premere  per confermare, quindi premere  per tornare alla schermata principale.















Se non viene premuto nessun pulsante, il salvataggio avviene automaticamente dopo 20s.

I minuti possono essere impostati a intervalli di 10 minuti

L'indicazione ON sotto l'ora nella schermata principale indica che il Timer Start (ON) è correttamente programmato.

4. INTERFACCIA UTENTE (segue)







Programmazione Timer- Stop (OFF)

- Tenere premuto  per 2 secondi, fino a quando l'icona  non inizia a lampeggiare.
- Premere , l'ora di inizio lampeggia .
- Premere , l'ora di fine lampeggia .
- Premere  e impostare le ore con  e .
- Premere  e impostare i minuti con  e .
- Premere  per confermare, quindi premere  per tornare alla schermata principale.

Se non viene premuto nessun pulsante, Il salvataggio avviene automaticamente dopo 20s.







I minuti possono essere impostati a intervalli di 10 minuti. L'indicazione OFF sopra all'ora nella schermata principale indica che il Timer Stop (OFF) è correttamente programmato.

Consultazione dei Timer







- Tenere premuto  per 2 secondi, fino a quando l'icona  non inizia a lampeggiare.
- Premere , l'ora di inizio  lampeggia.
- Premere , l'ora di fine  lampeggia.
- Premere  per tornare alla schermata principale.

Nella schermata principale, se è programmato un Timer Start e/o un Timer Stop, compare l'icona .

Eliminare un Timer Start (ON) o Stop (OFF)











- Tenere premuto  per 2 secondi, fino a quando l'icona  non inizia a lampeggiare.
- Premere 2 volte , l'ora di inizio lampeggia .
- Premere  per cancellare il Timer Start .

Alla fine del passaggio 3, premere  per tornare alla schermata principale oppure continuare procedendo con il passaggio 4.

- Premere , per accedere all'ora di fine .
- Premere , l'ora di fine lampeggia .
- Premere  per cancellare il Timer Stop .
- Premere  per tornare alla schermata principale.

4. INTERFACCIA UTENTE (segue)

















Eliminare un Timer Stop (OFF)

- Tenere premuto  per 2 secondi, fino a quando l'icona  non inizia a lampeggiare.
- Premere 2 volte , l'ora di inizio lampeggia .
- Premere  per accedere all'ora di fine .
- Premere , l'ora di fine lampeggia .
- Premere  per cancellare il Timer Stop .
- Premere  per tornare alla schermata principale.

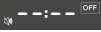









4.5 Regolazione della funzione Timer in modalità SILENZIOSO

La modalità SILENZIOSO permette di usare la pompa di calore risparmiando energia e generando molto meno rumore quando le esigenze di riscaldamento sono ridotte (mantenimento della vasca a temperatura o necessità di avere un funzionamento ultrasilenzioso).

Programmazione del Timer in modalità SILENZIOSO

- Tenere premuto  per 2 secondi, fino a quando l'icona  non inizia a lampeggiare.
- Premere , l'icona  lampeggia.
- Premere ,  lampeggia.
- Premere  e impostare l'ora di inizio con  e .
- Premere prima  e poi ,  lampeggia.
- Premere  e impostare l'ora di fine con  e .
- Premere  per confermare, quindi premere  per tornare alla schermata principale.

Eliminazione del Timer in modalità SILENZIOSO







- Tenere premuto  per 2 secondi, fino a quando l'icona  non inizia a lampeggiare.
- Premere , l'icona  lampeggia.
- Premere , l'ora di inizio  lampeggia.
- Premere , solo le ore lampeggiano.
- Premere ,  lampeggia.
- Premere  per tornare alla schermata principale.

L'eliminazione del Timer Start causa sistematicamente anche l'eliminazione del Timer Stop.

Il passo di regolazione è "di ora in ora".

4. INTERFACCIA UTENTE (segue)

Consultazione del Timer in Modalità silenzioso

- Tenere premuto  per 2 secondi, fino a quando l'icona  non inizia a lampeggiare.
- Premere , l'icona  lampeggia.
- Premere  per visualizzarne l'ora di inizio.
- Premere  per visualizzarne l'ora di fine.
- Premere  per tornare alla schermata principale.

Nella schermata principale, se è programmato un Timer Start o un Timer Stop per la modalità SILENZIOSO, compare l'icona .

4.6 Associazione Bluetooth - Comando a distanza

La pompa di calore prevede la funzione Bluetooth.

Grazie all'app "*EyesPool Inverter Connect*", è possibile utilizzare lo smartphone come un telecomando per controllare la pompa di calore entro un limite di 10 m in campo libero.

Per impostare la funzione  **Bluetooth**:

- ▶ Scaricare l'app gratuita "*EyesPool Inverter Connect*" da  o



- ▶ Creare un account nell'app.
- ▶ Seguire le istruzioni del video (v. link seguente) per associare lo smartphone e la pompa di calore:
<https://www.hayward.fr/article/tutoriels-hayward/s-line-pro-bluetooth-appairage>



4. INTERFACCIA UTENTE (segue)

4.7 Selezione della modalità di funzionamento

Riscaldamento - Auto - Raffreddamento



Se la pompa di calore è impostata dall'installatore in modalità Solo caldo o Solo freddo, non sarà più possibile modificare la modalità.

Per cambiare modalità, premere : Riscaldamento - Auto - Raffreddamento.

Riscaldamento

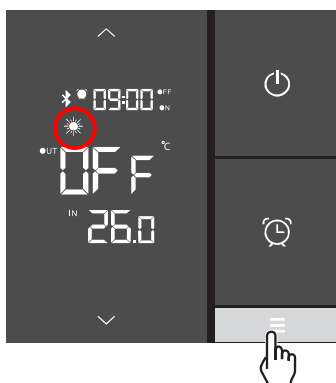

Auto



Raffreddamento







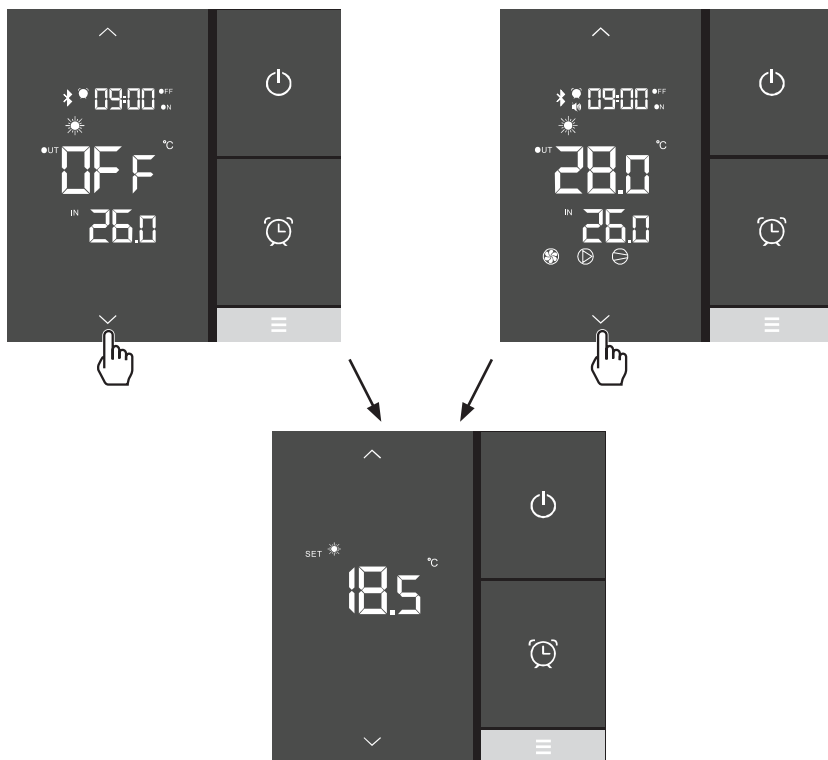

4. INTERFACCIA UTENTE (segue)

4.8 Regolazione e visualizzazione del set point

Temperatura dell'acqua desiderata

La configurazione del set point avviene sia in modalità OFF che in modalità ON, con una precisione di 0,5°C.



- Premere  o  per far sì che il set point lampeggi.
- Premere  o  per impostare il set point desiderato.
- Premere  per confermare o  per annullare.

Se non viene premuto nessun pulsante, la configurazione è salvata automaticamente dopo 5 secondi.







Per evitare di alterare i liner, si consiglia di non superare mai la temperatura di 30°C.

4. INTERFACCIA UTENTE (segue)

4.9 Blocco e sblocco del touch screen

Il blocco e lo sblocco del touch screen possono avvenire sia in modalità ON che in modalità OFF.

- Tenere premuto  per 5 secondi fino a quando non verrà visualizzata l'icona .
- Per sbloccare lo schermo, tenere premuto  fino a quando l'icona  non sarà scomparsa.

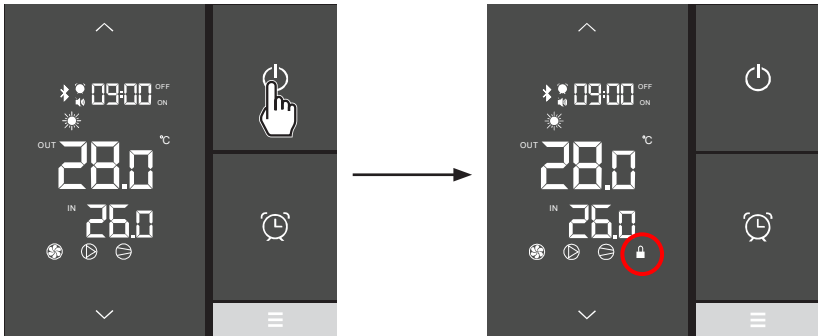

5. MANUTENZIONE E SVERNAMENTO

5.1 Manutenzione

Per garantire la longevità e il corretto funzionamento dell'Unità di Riscaldamento a Pompa di Calore per Piscine, le presenti operazioni di manutenzione devono essere effettuate 1 volta all'anno.

- Pulire l'evaporatore con una spazzola morbida, un getto di aria compressa o con acqua (**Attenzione: non utilizzare in nessun caso idropulitrici**).
- Controllare che lo scarico della condensa avvenga correttamente.
- Controllare che i collegamenti idraulici e quelli elettrici siano serrati correttamente.
- Controllare la tenuta idraulica del condensatore.
- Far controllare la tenuta del circuito frigorifero al rilevatore di perdite da un **professionista autorizzato**.



Prima di eseguire qualsiasi operazione di manutenzione, assicurarsi che l'unità sia scollegata da ogni fonte di corrente elettrica. Le operazioni di manutenzione devono essere effettuate esclusivamente da personale qualificato e abilitato alla manipolazione di fluidi frigoriferi.

5.2 Svernamento

- Mettere l'unità in Modalità "OFF".
- Interrompere l'alimentazione dell'unità.
- Svuotare il condensatore tramite l'apposito scolo per evitare eventuali rischi di degrado. (elevato rischio di congelamento).
- Chiudere la valvola by-pass e svitare i raccordi di unione ingresso/uscita.
- Eliminare dal condensatore l'acqua stagnante residua servendosi di una pistola ad aria compressa.
- Ostruire l'ingresso e l'uscita dell'acqua dell'unità, al fine di evitare l'eventuale intrusione di corpi estranei.
- Coprire l'unità con l'apposito telo per l'inverno.



Una volta attivato, il Timer rimane attivo 7 giorni su 7.

6. APPENDICI

6.1 Schemi Elettrici

HP5081DT3LVM / HP5111DT3LV

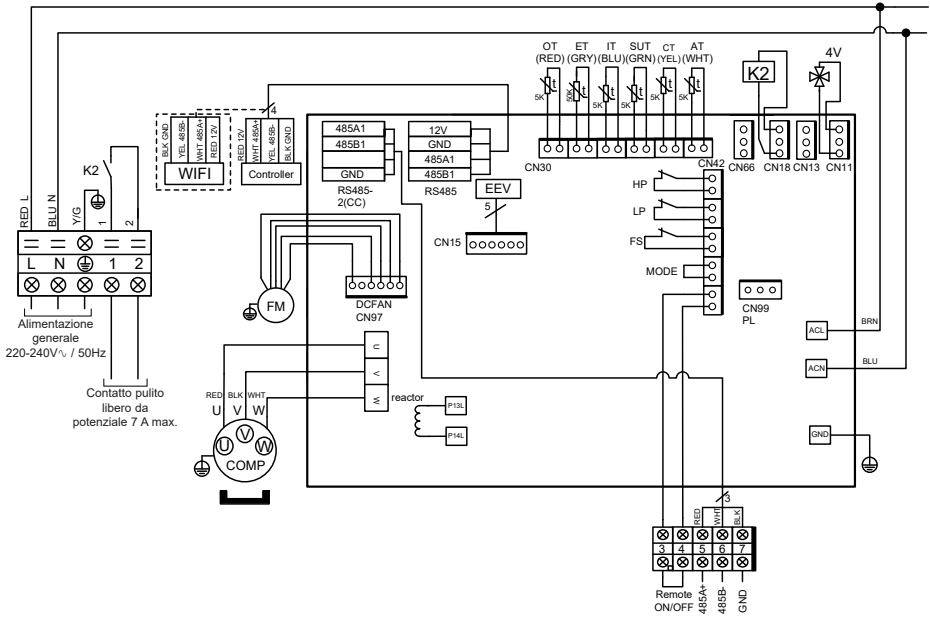

LEGENDA:

- | | |
|--|---|
| AT : SONDA TEMPERATURA ARIA | LP : PRESSOSTATO BASSA PRESSIONE |
| COMP : COMPRESSORE | OT : SONDA TEMPERATURA ACQUA IN USCITA |
| CT : SONDA TEMPERATURA EVAPORATORE | SUT : SONDA TEMPERATURA ASPIRAZIONE |
| EEV : REGOLATORE DI PRESSIONE ELETTRONICO | 4V : VALVOLA 4 VIE |
| FM : MOTORE VENTOLA | K2 : CONTATTO PULITO LIBERO DA POTENZIALE 7 A MAX. |
| FS : RILEVATORE ACQUA | ET : SONDA TEMPERATURA DI MANDATA |
| HP : PRESSOSTATO ALTA PRESSIONE | --- : OPTIONAL |
| IT : SONDA TEMPERATURA ACQUA IN INGRESSO | |

6. APPENDICI (segue)

HP5151DT3LV

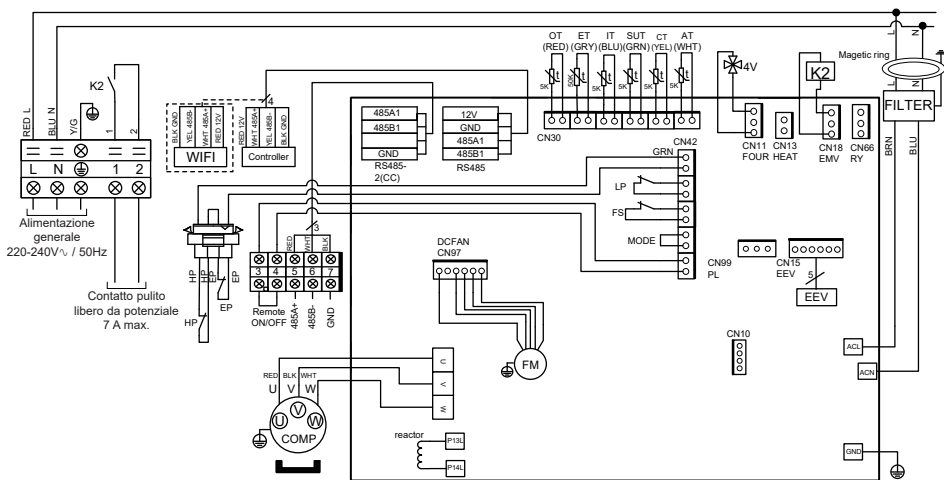

LEGENDA:

- | | |
|--|---|
| AT : SONDA TEMPERATURA ARIA | LP : PRESSOSTATO BASSA PRESSIONE |
| COMP : COMPRESSORE | OT : SONDA TEMPERATURA ACQUA IN USCITA |
| CT : SONDA TEMPERATURA EVAPORATORE | SUT : SONDA TEMPERATURA ASPIRAZIONE |
| EEV : REGOLATORE DI PRESSIONE ELETTRONICO | 4V : VALVOLA 4 VIE |
| FM : MOTORE VENTOLA | K2 : CONTATTO PULITO LIBERO DA POTENZIALE 7 A MAX. |
| FS : RILEVATORE ACQUA | ET : SONDA TEMPERATURA DI MANDATA |
| HP : PRESSOSTATO ALTA PRESSIONE | OPTIONAL : OPTIONAL |
| IT : SONDA TEMPERATURA ACQUA IN INGRESSO | |

6. APPENDICI (segue)

6.2 Collegamenti priorità riscaldamento pompa monofase

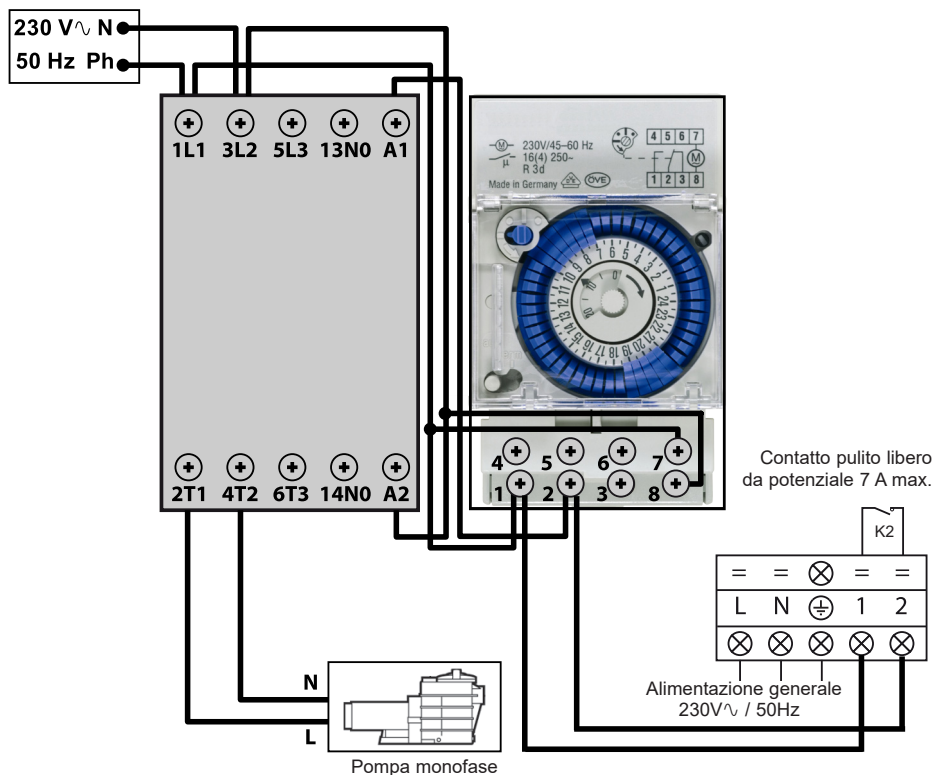

I morsetti 1 e 2 offrono un contatto pulito libero da potenziale, senza polarità 230 V~/50 Hz. Collegare i morsetti 1 e 2 come indicato nello schema di cablaggio di cui sopra per garantire il funzionamento della pompa di filtraggio per un ciclo di 2 min. ogni ora qualora la temperatura all'interno della vasca fosse inferiore al set point impostato.



Non collegare l'alimentazione della pompa di filtraggio direttamente ai morsetti 1 e 2.

6. APPENDICI (segue)

6.3 Esplosi e parti di ricambio

HP5081DT3LV / HP5111DT3LV / HP5151DT3LV

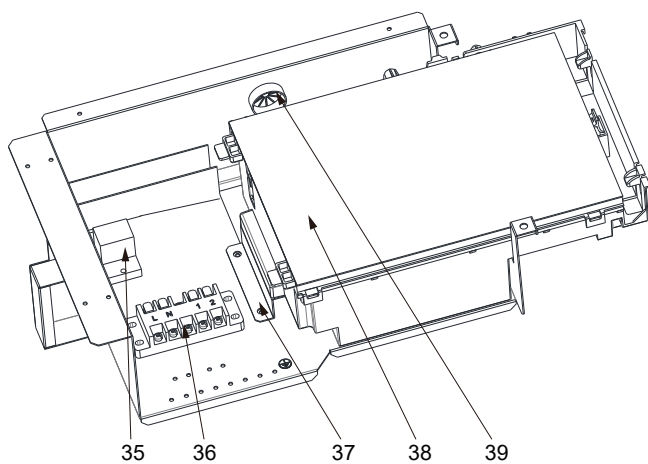
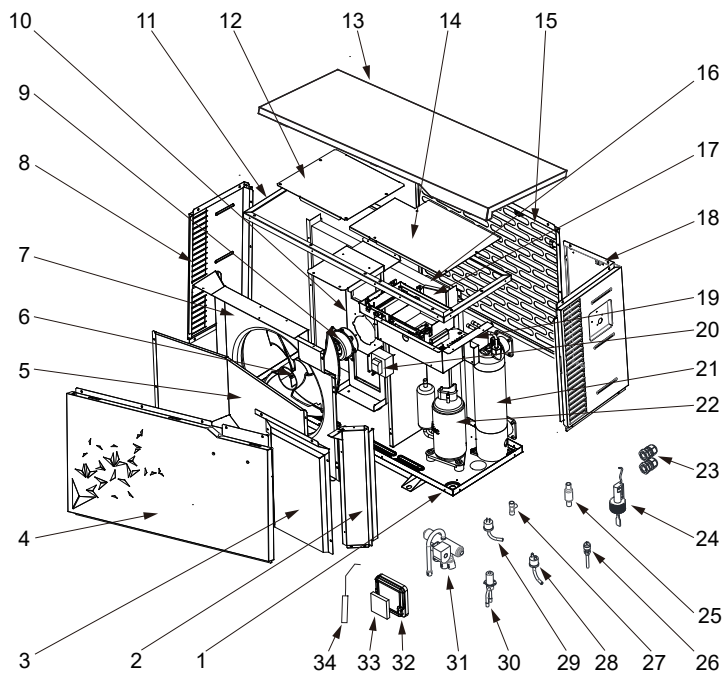

6. APPENDICI (segue)

Num.	Designazione	Rif.	HP5081DT3LV	HP5111DT3LV	HP5151DT3LV
1	/	/	/	/	/
2	/	/	/	/	/
3	/	/	/	/	/
4	Pannello anteriore	HWX80715842	✓	✓	n/a
		HWX80715857	n/a	n/a	✓
5	/	/	/	/	/
6	Elica ventilatore	HWX301030000006	✓	✓	n/a
		HWX20000270004	n/a	n/a	✓
7	/	/	/	/	/
8	Pannello sinistro	HWX80713420	✓	✓	n/a
		HWX80713423	n/a	n/a	✓
9	Motore ventola DC	HWX80200018	✓	✓	n/a
		HWX20000330132	n/a	n/a	✓
10	Supporto motore	HWX80708597	✓	✓	n/a
		HWX80709977	n/a	n/a	✓
11	/	/	/	/	/
12	/	/	/	/	/
13	Pannello superiore	HWX80708601	✓	✓	n/a
		HWX80709984	n/a	n/a	✓
14	/	/	/	/	/
15	Pannello posteriore	HWX80710829	✓	✓	n/a
		HWX80710966	n/a	n/a	✓
16	Evaporatore a piastre	HWX80600849	✓	n/a	n/a
		HWX80600781	n/a	✓	n/a
		HWX80600835	n/a	n/a	✓
17	/	/	/	/	/
18	Pannello destro	HWX80713421	✓	✓	n/a
		HWX80713424	n/a	n/a	✓
19	/	/	/	/	/
20	Reattanza	HWX82500020	✓	✓	n/a
		HWX82500021	n/a	n/a	✓
21	Condensatore Titanio/PVC	HWX80600939	✓	n/a	n/a
		HWX80600940	n/a	✓	✓
		HWX80600096	n/a	n/a	✓
22	Compressore	HWX20000110448	✓	✓	n/a
		HWX80100046	n/a	n/a	✓
23	Premistoppa	HWX20012249	✓	✓	n/a
		HWX20012238	n/a	n/a	✓
24	Rilevatore portata acqua	HWX83000068	✓	✓	✓
25	Filtro Ø9.7-Ø9.7 (Ø19)	HWX20000140178	✓	✓	n/a
	Filtro Ø9.7-Ø9.7 (Ø28)	HWX20041444	n/a	n/a	✓
26	Rilevamento Pressione 40mm-1/2"	HWX20000140150	✓	✓	✓
27	Connettore T Ø9.52-2 xØ6.35(T) x 1.0	HWX30403000002	✓	✓	n/a
	Connettore T Ø6.5-2 x Ø6.5(T) x 0.75	HWX20001460	n/a	n/a	✓
28	Pressostato Bassa pressione NO 0.30MPa/0.15MPa	HWX20000360157	✓	✓	✓
29	Pressostato Alta pressione NC 3.2MPa/4.4MPa	HWX20013605	✓	✓	✓
30	Riduttore di pressione elettronico	HWX81000011	✓	✓	n/a
		HWX81000017	n/a	n/a	✓
31	Valvola 4 vie	HWX20041437	✓	✓	n/a
		HWX20000140485	n/a	n/a	✓
32	Supporto Controller	HWX80901004	✓	✓	✓
33	Controller LCD Bluetooth	HWX72200312	✓	✓	✓

6. APPENDICI (segue)

HP5081DT3LV / HP5111DT3LV / HP5151DT3LV

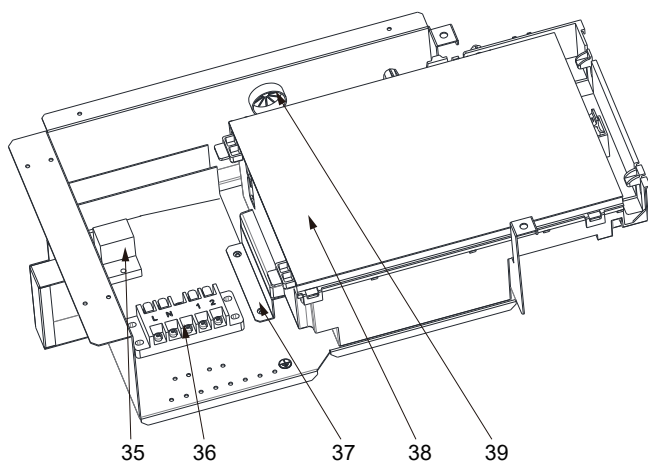
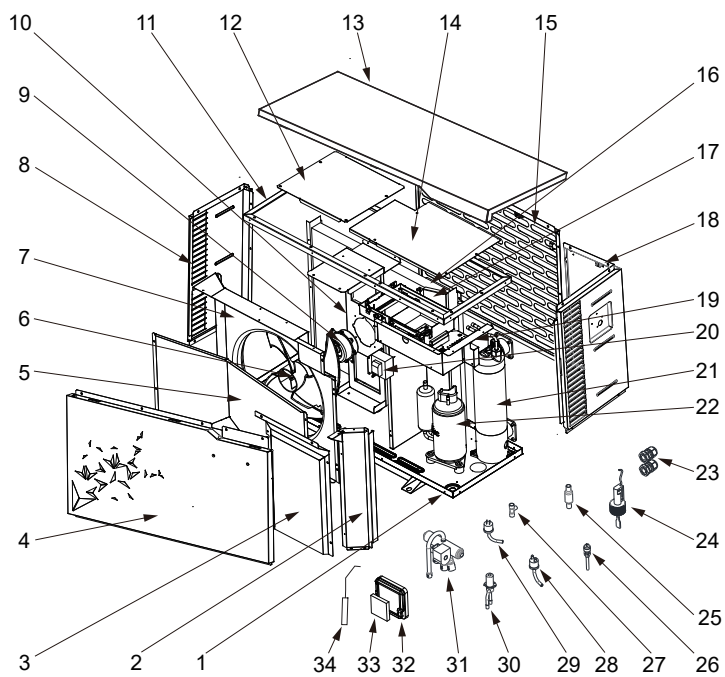

6. APPENDICI (segue)

Num.	Designazione	Rif.	HP5081DT3LV	HP5111DT3LV	HP5151DT3LV
34	Sonda uscita acqua 5k-410mm	HWX83000050	✓	✓	✓
	Sonda temperatura acqua in ingresso 5k-850mm	HWX83000052	✓	✓	✓
	Sonda scarico compressore 50k-660mm	HWX83000026	✓	✓	✓
	Sonda di aspirazione compressore 5k-560mm	HWX83000044	✓	✓	n/a
	Sonda di aspirazione compressore 5k-760mm	HWX83000053	n/a	n/a	✓
	Sonda antigelo 5k-680mm	HWX83000051	✓	✓	n/a
	Sonda antigelo 5k-1040mm	HWX83000045	n/a	n/a	✓
	Sonda temperatura aria 5k-350mm	HWX83000049	✓	✓	✓
35	Relè K2	HWX20000360297	✓	✓	✓
36	Morsettiera L-N-GND -5 connessioni 4mm ²	HWX40003901	✓	✓	✓
37	/	/	/	/	/
38	Scheda elettronica Driver	HWX72200168SL08	✓	n/a	n/a
		HWX72200168SL11	n/a	✓	n/a
		HWX72200168SL15	n/a	n/a	✓
39	/	/	/	/	/

6. APPENDICI (segue)



6.4 Risoluzione dei problemi



Alcuni dei presenti interventi devono essere eseguiti da un tecnico abilitato.

In caso di problemi sullo schermo compaiono le seguenti indicazioni:



In caso di più errori presenti, premere  o  per passare da un codice errore all'altro.

Fare riferimento alla tabella seguente.



Una volta risolto il problema, lo stato dell'errore si aggiorna automaticamente e il triangolo scompare.

6. APPENDICI (segue)

Problema	Codice errore	Descrizione	Soluzione
Guasto sonda acqua in ingresso (IT)	P01	Circuito aperto o cortocircuito	Controllare i collegamenti sul connettore prolunga o sostituire il sensore
Guasto sonda acqua in uscita (OT)	P02		
Guasto sonda temperatura esterna (AT)	P04		
Guasto sonda antigelo (CT)	P05		
Guasto sonda di aspirazione Compressore (SUT)	P07		
Guasto sonda di mandata Compressore (ET)	P08		
Protezione alta pressione	E01	Circuito aperto o cortocircuito	Controllare i collegamenti sul connettore prolunga o sostituire il sensore
			Controllare la portata d'acqua
			Controllare il sensore della portata d'acqua
			Controllare l'apertura delle valvole
			Controllare la valvola by-pass
			Controllare il livello di sporco dell'evaporatore
			Temperatura acqua troppo calda
			Problema incondensabile in seguito a manutenzione, svuotare e porre sottovuoto il circuito frigorifero
Carico fluido eccessivo, espellere il fluido in una bombola			
Protezione bassa pressione	E02	Circuito aperto o cortocircuito	Controllare i collegamenti sul connettore prolunga o sostituire il sensore
			Perdita rilevante di fluido frigorifero, cercare la perdita con il rilevatore
			Portata aria troppo bassa, controllare la velocità di rotazione della ventola
			Controllare il livello di sporco dell'evaporatore e pulirne la superficie

6. APPENDICI (segue)

Problema	Codice errore	Descrizione	Soluzione
Guasto sensore di portata	E03	Circuito aperto o cortocircuito	Controllare i collegamenti CN29/OVT della scheda o sostituire il sensore
			Manca acqua, controllare che la pompa di filtrazione funzioni correttamente
			Controllare che le valvole di arresto siano aperte
			Controllare la regolazione della valvola by-pass
Differenza di temperatura Ingresso/ Uscita > 13°C	E05	Applicabile solo in modalità Freddo	Manca acqua, controllare che la pompa di filtrazione funzioni correttamente
			Controllare che le valvole di arresto siano aperte
			Controllare la regolazione della valvola by-pass
Protezione Antigelo	E07	Temperatura acqua in uscita < 4°C	Interrompere il funzionamento della pompa di calore, spurgare il condensatore antigelo
Problema di comunicazione	E08	Assenza di comunicazione tra scheda elettronica e interfaccia utente	Controllare collegamenti e cavi - v. schema elettrico
Protezione Antigelo di livello 1	E19	2°C < Temperatura acqua < 4°C e Temperatura aria < 0°C	Interrompere il funzionamento della pompa di calore, spurgare il condensatore antigelo, la pompa di calore avvia automaticamente la pompa di filtrazione per evitare il gelo
Protezione Antigelo di livello 2	E29	Temperatura acqua < 2°C e Temperatura aria < 0°C	Interrompere il funzionamento della pompa di calore, spurgare il condensatore antigelo, la pompa di calore avvia automaticamente la pompa di filtrazione e la pompa di calore per evitare il gelo.
Guasto motore ventola	F03 I	Motore bloccato o errore di connessione	Controllare che la ventola possa girare liberamente; controllare i collegamenti CN97/DCFAN; sostituire il motore
Guasto motore ventola	F05 I	Errore di connessione	Controllare i collegamenti DCFAN/ CN97; sostituire il motore
Temperatura esterna troppo bassa	EP	Raggiungimento del limite di funzionamento	Spegnimento pompa di calore
La pompa di calore non parte	- - - 0FF	Contatto (5-6) Remote On/Off Aperto	Chiudere il contatto (5-6) Remote On/Off (v. schema elettrico)

6. APPENDICI (segue)

6.5 Garanzia

CONDIZIONI DI GARANZIA

Tutti i prodotti HAYWARD sono garantiti contro tutti i difetti di fabbricazione o di materiale per un periodo di due anni dalla data di acquisto. Le eventuali richieste garanzia dovranno essere accompagnate dalla prova di acquisto comprovante detta data. Si raccomanda pertanto di conservare la fattura.

La garanzia HAYWARD è limitata alla riparazione o alla sostituzione, a discrezione della stessa HAYWARD, dei prodotti difettosi solo ed esclusivamente in caso di normale utilizzo e in conformità alle prescrizioni riportate nel manuale d'uso del prodotto; sarà altresì riconosciuta valida, qualora il prodotto in questione non sia stato in alcun caso alterato ed utilizzato esclusivamente in abbinamento a parti e componenti HAYWARD. Gli eventuali danni dovuti a gelo e ad attacchi di agenti chimici non sono coperti da garanzia.

Ogni altra spesa (trasporto, manodopera...) è esclusa dalla garanzia.

HAYWARD declina ogni responsabilità per danni, diretti o indiretti, riconducibili a installazione, collegamento o utilizzo non corretti del prodotto.

Per richiedere un intervento in garanzia e la riparazione o la sostituzione di un componente, rivolgersi ad un rivenditore autorizzato. Salvo previo accordo scritto, gli eventuali resi saranno respinti.

I componenti soggetti ad usura non sono coperti dalla garanzia.

Pagina lasciata intenzionalmente bianca



S.Line Pro *Fi*

VARMEPUMPE TIL SVØMMEBASSENG



Installerings- og brukerveiledning

INNHold

1. INNLEDNING	1
----------------------	----------

2. SPESIFIKASJONER	4
2.1 Varmepumpens ytelse	4
2.2 Driftsområde	5
2.3 Dimensjoner	6

3. INSTALLERING OG TILKOBLING	7
3.1 Skjematisk diagram	7
3.2 Varmepumpe	7
3.3 Vanntilkobling	8
3.4 Elektrisk tilkobling	9
3.5 Førstegangs oppstart	10

4. BRUKERGRENSESNIITT	12
4.1 Generell presentasjon	12
4.2 Justering av vannmengden	14
4.3 Stilling av klokken	15
4.4 Stille inn timerne Av/På	15
4.5 Stille inn Timer-funksjon i SILENCE-modus	17
4.6 Bluetooth paring - Fjernkontroll	18
4.7 Velge driftsmodusen	19
4.8 Innstilling og visning av settpunktet	20
4.9 Låsing og opplåsing av berøringsskjermen	21

5. VEDLIKEHOLD OG VINTERKLARGJØRING	22
5.1 Vedlikehold	22
5.2 Vinterklargjøring	22

6. VEDLEGG	23
6.1 Koblingsskjemaer	23
6.2 Kobling med prioritet på enfaset varmpumpe	25
6.3 Sprengskisse og reservedeler	26
6.4 Service-manual	30
6.5 Garanti	33

Vennligst les nøye og ta vare på for fremtidig referanse.

Dette dokumentet må være levert til svømmebassengets eier, og må oppbevares på et trygt sted.

1. INNLEDNING

Takk for at du har kjøpt denne Hayward varmpumpen til svømmebasseng. S.LINE PRO varmpumpe har blitt utformet i henhold til strenge produksjonsstandarder for å oppfylle det høye kvalitetsnivået.

S.LINE PRO varmpumper vil gi deg enestående ytelser gjennom hele badesesongen ved at de tilpasser effekt, elektrisk forbruk og støynivå etter bassengets oppvarmingsbehov takket være kontrollogikken FULL INVERTER.



Les instruksene i denne veiledningen nøye før du tar enheten i bruk.

S.LINE PRO varmpumper er kun forutsett til å varme opp bassengvann, og materialet må ikke brukes til andre bruksområder.

Denne brukerveiledningen inneholder all nødvendig informasjon vedrørende installasjon, feilretting og vedlikehold.

Les denne brukerveiledningen nøye før du åpner enheten eller utfører vedlikeholdsoperasjoner på den. Produsenten av dette produktet vil ikke i noen tilfeller bli holdt ansvarlig for skader på brukeren eller ødeleggelser på enheten som er en følge av feil ved installasjon, feilretting eller unødvendig vedlikehold. Det er svært viktig at instruksene i denne brukerveiledningen blir nøye fulgt på ethvert tidspunkt.

Alle anbefalinger som ikke etterkommes vil oppheve garantien.

INNLEDNING (fortsetter)



SIKKERHETSINSTRUKSER



Dette apparatet inneholder R32.

Det må ikke brukes noe annet kuldemedium enn R32. Enhver annen gass blandet med R32 kan føre til unormalt høye trykk som igjen kan forårsake feil eller eksplosjon av rørene samt personskade.

Bruk kobberrør som er i samsvar med standarden EN 12375-1 (Mai 2020) og det europeiske direktivet om trykkutstyr 97/23 / EF under reparasjoner eller vedlikehold.

Da varmpumpen er under trykk må man aldri forsøke å stikke hull på eller lodde rørene. Det er fare for eksplosjon.

Apparatet må ikke utsettes for flammer, gnister eller andre antenningskilder. Det vil kunne eksplodere og føre til alvorlige skader eller død.



Varmepumpen er kun forutsett for å bli installert på utsiden av bygninger.

- Dersom varmpumpen skal lagres må den oppbevares i et godt ventilert lokale med et gulvareal på mer enn $A_{\min}(\text{m}^2)$ gitt med følgende formel:
$$A_{\min} = (M / (2.5 \times 0.22759 \times h_0))^2$$

M er mengden kuldemedium i apparatet i kg, og h_0 er lagringshøyden. For lagring på gulvet $h_0 = 0,6$ m.
- Enheten må installeres av kvalifisert personell.
- Varmepumpen må ikke installeres på et underlag som risikerer å forsterke enhetens vibrasjoner.
- Sjekk at underlaget som er forutsett for enheten er riktig dimensjonert for vekten av apparatet.
- Varmepumpen må ikke installeres på et sted hvor støynivået vil kunne forsterkes, eller på et sted hvor støyen fra enheten vil kunne være til sjenanse for naboene.
- Alle elektriske tilkoplinger må utføres av en kvalifisert og godkjent elektriker og i henhold til gjeldende standarder i installasjonslandet jfr. § 3.4.
- Bryt hovedstrømtilførselen og skillebryteren før alt elektrisk arbeid. Dersom dette ikke blir gjort kan det forårsake elektrisk sjokk.
- Sjekk at jordledningen ikke er kuttet eller frakoplet før installasjon.

INNLEDNING (fortsetter)

- Kople til og stramme tilførselskabelen på riktig måte. Dersom forbindelsen er dårlig kan det føre til skade på de elektriske delene.
- Dersom varmpumpen utsettes for vann eller fuktig miljø, kan det føre til elektrisk sjokk. Utvis stor forsiktighet.
- Dersom du detekterer en feil eller en unormal situasjon, må ikke varmpumpen installeres, men ta umiddelbart kontakt med forhandleren.
- Vedlikeholdet og de ulike operasjonene må utføres med de anbefalte intervallene og på de anbefalte tidspunktene slik det er angitt i denne brukerveiledningen.
- Reparasjoner må utføres av kvalifisert personell.
- Bruk kun originale reservedeler.
- Det må aldri brukes en annen rengjøringsprosedyre enn den som fabrikanten har anbefalt.

Viktig informasjon angående det brukte kuldemediet.

Dette produktet inneholder fluorholdige klimagasser som er berammet av Kyoto-protokollen Disse gassene må ikke frigjøres i atmosfæren.

Kuldemedium: R32

GWP-verdi(1): 675, Verdi basert på den 4. rapporten fra IPCC.

Mengden kuldemedium basert på regelverket F Gaz 517/2014 er angitt på dataplatten på enheten.

Periodiske inspeksjoner av lekkasje av kuldemedium kan bli påkrevet avhengig av den europeiske eller lokale lovgivningen. Ta kontakt med din lokale forhandler for mer informasjon.

(1) Global warming potential (GWP))

2. SPESIFIKASJONER

2.1 Varmepumpens ytelse

Modeller	S.LINE PRO	HP5081DT3LV	HP5111DT3LV	HP5151DT3LV
Tilførselsspening	V	220V-240V ~ / 1ph / 50Hz		
Kuldemedium	/	R32		
Last	kg	0,45	0,50	0,65
Masse i teqCO ₂	/	0,30	0,34	0,44
Hyppighet for lekkasjekontroll	/	Er ikke påkrevet, men årlig kontroll anbefales		
Oppvarmingskapasitet Min--Maks ^(a)	kW	2,83 -- 8,16	1,95 -- 10,90	5,27 -- 15,66
Absorbert elektrisk effekt Min--Maks ^(a)	kW	0,212 -- 1,19	0,150 -- 1,92	0,457 -- 2,80
Nominell strømverdi Min--Maks ^(a)	A	1,41 -- 5,20	1,05 -- 8,49	2,04 -- 12,28
COP Maks--Min ^(a)	/	13,30 -- 6,81	12,92 -- 5,67	11,53 -- 5,59
Oppvarmingskapasitet Min--Maks ^(b)	kW	1,77 -- 5,91	1,86 -- 8,40	3,81 -- 11,67
Absorbert elektrisk effekt Min--Maks ^(b)	kW	0,31 -- 1,28	0,30 -- 1,83	0,588 -- 2,71
COP Maks--Min ^(b)	/	5,70 -- 4,62	6,20 -- 4,59	6,48 -- 4,31
Maksimum strømverdi	A	6,50	10,30	14
Sikringsstørrelse	gG	10	12	16
Effektbryter Kurve C	C	10	12	16
Startstrøm	A	< Maksimum strømverdi		
Hydraulisk tilkoping	mm	50 mm		
Nominell vannstrøm ^(a)	m ³ /h	3,50	4,60	6,70
Fall i vanntrykk (maks.)	kPa	8	5	10
Kompressor	/	DC Inverter MITSUBISHI ELECTRIC		DC Inverter Mitsubishi
Type	/	Dobbeltroterende		Dobbeltroterende
Antall	/	1		
Svingningsmotstand ved 20°C	Ohm	1,91 +/- 5%		0,95 +/- 5%
Vifte	/	Aksial		
Antall		1		
Diameter	mm	405		500
Antall rotor	/	3		
Motor	/	DC-omformer		
Antall	/	1		
Rotasjonshastighet	Omdr/min	500 -- 800	500 -- 900	500 -- 750
Hastighet i Silent Mode	Omdr/min	500	500	500
Lydtrykknivå ved 1 m	dB(A)	45,1	48,6	54,1
Lydtrykknivå ved 10 m	dB(A)	27,9	31,6	36,9
Enhetens dimensjoner, netto (L-I-H)	mm	1011 / 430 / 622		1025 / 480 / 768
Vekt	kg	61	61	87



(a) Tørrluft 27°C – Relativ fuktighet 78% - Temperatur til vanninnløp 26°C.

(b) Tørrluft 15°C – Relativ fuktighet 71% - Temperatur til vanninnløp 26°C.

2. SPESIFIKASJONER (fortsetter)

2.2 Driftsområde

Bruk varmepumpen i de følgende temperatur- og fuktighetsområder for å sikre en trygg og effektiv drift.

	Oppvarmingsmodus 	Kjølemodus 
Utetemperatur	-7°C – +35°C	+7°C – +43°C
Vanntemperatur	+12°C – +32°C	+8°C – +40°C
Relativ luftfuktighet	< 80%	< 80%
Innstillingsområde for settpunkt	+15°C – +32°C	+8°C – +32°C



Hvis temperatur eller luftfuktighet ikke samsvarer med disse betingelsene, kan sikkerhetsanordninger aktiveres og varmepumpen slutte å fungere.



Maksimumstemperaturen for oppvarming er begrenset til 32°C for å unngå forringelse av foringene. Hayward fraskriver seg alt ansvar i tilfelle av en bruk utover 32°C.

2. SPESIFIKASJONER (fortsetter)

2.3 Dimensjoner

Modeller:

HP5081DT3LV / HP5111DT3LV / HP5151DT3LV

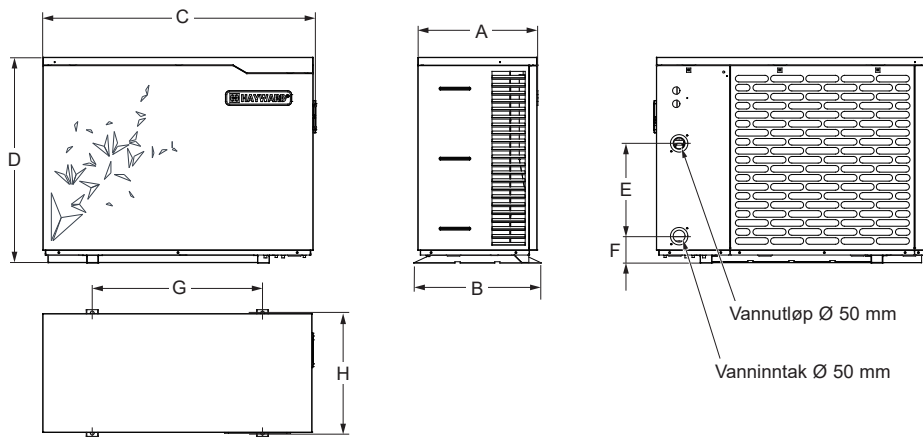

Enhet: mm

Nummer	Model	HP5081DT3LV / HP5111DT3LV	HP5151DT3LV
	A		393
B		430	480
C		1011	1030
D		621,5	776
E		350	350
F		97,5	102
G		625	645
H		406	456

3. INSTALLERING OG TILKOBLING

3.1 Skjematisk diagram

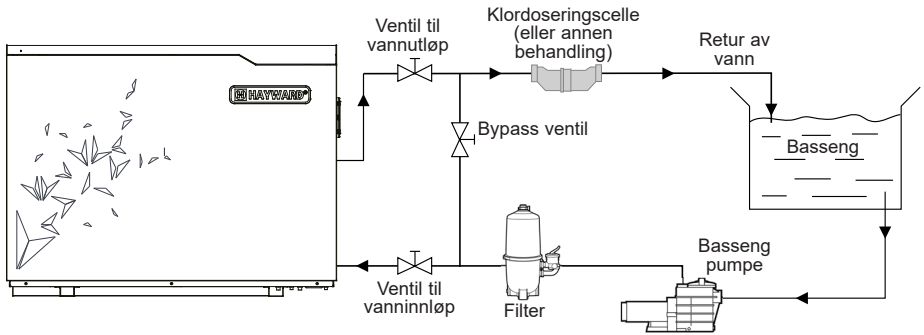

Merk: Varmepumpen er levert uten noe utstyr for behandling eller filtrering. Elementene som presenteres i diagrammer er deler som må leveres av installatøren.

3.2 Varmepumpe



Plasser varmpumpen utendørs, og ikke i lukkede tekniske lokaler.

Plassert under beskyttelse, må minsteavstander angitt nedenfor følges for å unngå resirkulering av luft, og en degradering av varmpumpens i totale prestasjoner.

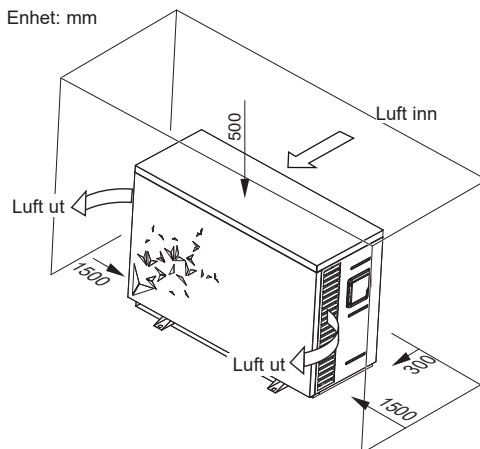

3. INSTALLERING OG TILKOBLING (fortsetter)



Helst installere varmepumpen på en frittliggende betongplate eller spesielt feste til dette formålet, og monter varmepumpen på de medfølgende Silentbloc-underlagene (skruer og skiver ikke inkludert).

Maksimal avstand for installasjon mellom varmepumpen og bassenget 15 meter.

Total tur-retur lengde for vannkanalene 30 meter.

Isoler vannkanaler på bakken og under jorden.

Varmepumpen må bygges opp og installeres med en minimum avstand fra bassenget, i henhold til standard NF C 15-100 (minst 3,5 meter fra bassenget i Frankrike) eller i henhold til gjeldende regler og forskrifter i hvert enkelt land.

Varmepumpen må ikke installeres i nærheten av en varmekilde.

I land hvor det er mye snø, bør det bygges opp et tak over maskinen for å unngå at snø bygger seg over ribbene på varmepumpen.

3.3 Vanntilkobling

Varmepumpen leveres med to koblingsdeler med diameter på 50 mm. Bruk PVC-rør på Ø 50 mm for vannkanaler. Koble varmepumpens vanninnløp til kanalen fra filteringsenheten, og koble deretter varmepumpens vannutløp til kanalen som går til bassenget (se diagram nedenfor).

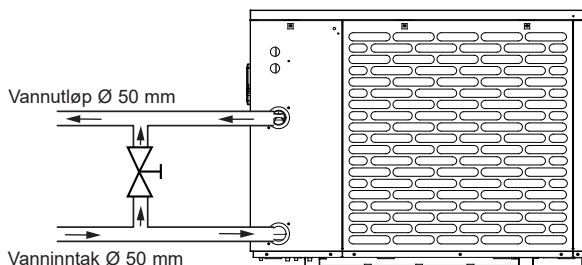

Installer en bypassventil mellom varmepumpens vanninnløp og vannutløp.



Dersom automatisk fordeler eller klordoseringscelle benyttes, må det være installert etter varmepumpen, for å beskytte Titanium-kondensatoren mot en for stor konsentrasjon av kjemiske stoffer.



Sørg for å installere bypassventilen og de medfølgende koblingsdelene ved enhetens vanninnløp og vannutløp, for å forenkle tømming om vinteren, for å forenkle tilgang eller demontering for vedlikehold.

3. INSTALLERING OG TILKOBLING (fortsetter)

3.4 Elektrisk tilkobling



Den elektriske installasjonen og kabling av dette utstyret må være i overensstemmelse med lokale forskrifter for installasjoner.

F	NF C15-100	GB	BS7671:1992
D	DIN VDE 0100-702	EW	EVHS-HD 384-7-702
A	ÖVE 8001-4-702	H	MSZ 2364-702/1994/MSZ 10-553 1/1990
E	UNE 20460-7-702 1993, RECBT ITC-BT-31 2002	M	MSA HD 384-7-702.S2
IRL	Wiring Rules + IS HD 384-7-702	PL	PN-IEC 60364-7-702:1999
I	CEI 64-8/7	CZ	CSN 33 2000 7-702
LUX	384-7.702 S2	SK	STN 33 2000-7-702
NL	NEN 1010-7-702	SLO	SIST HD 384-7-702.S2
P	RSIUEE	TR	TS IEC 60364-7-702



Kontroller at den tilgjengelige strømforsyningen og nettfrekvensen stemmer overens med operasjonelle krav, og tar hensyn til den spesifikke plasseringen til apparatet, og nødvendig strøm til å drive alle andre apparater som er koblet til samme krets.

**HP5081DT3LV / HP5111DT3LV / HP5151DT3LV
230V \sim +/- 10 % 50 Hz 1 Fase**

Følg tilsvarende koblingsskjema i vedlegg.

Tre tilkoblinger er til strømforsyning, og to til å styre filtreringspumpen (servomekanisme).

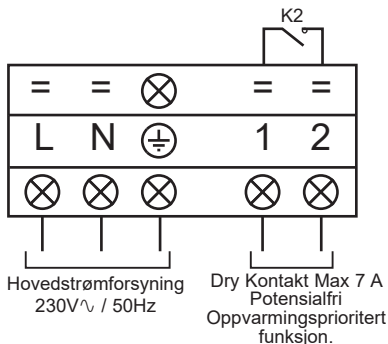

3. INSTALLERING OG TILKOBLING (fortsetter)



Strømledningen skal være utstyrt med en sikring av typen gG eller en effektbryter Kurve C, samt en 30mA jordfeilbryter (se tabell nedenfor).

Modeller		HP5081DT3LV	HP5111DT3LV	HP5151DT3LV
Elektrisk strømforsyning	V/Ph/Hz	230V~ 50Hz	230V~ 50Hz	230V~ 50Hz
Sikringsstørrelse av typen gG	A	10 gG	12 gG	16 gG
Effektbryter Kurve C	A	10 C	12 C	16 C
Kabelseksjon	mm ²	3G 2,5	3G 2,5	3G 2,5



Bruk en kabel av typen RO 2V / R 2V eller tilsvarende.



Kabelseksjonene er gitt for en lengde på maksimalt 25 meter. De må allikevel kontrolleres og tilpasses de gjeldene installasjonsforholdene.



Pass alltid på å stanse hovedstrømforsyningen før du åpner den elektriske kontrollboksen.

3.5 Førstegangs oppstart

Oppstartsprosedyre - når installasjonen er fullført bør du gjøre følgende:

- 1) Roter viften for hånd for å sikre at den kan rotere fritt for hånd, og at spiralen er riktig festet til motorakselen.
- 2) Se til at enheten er riktig tilkoblet til hovedstrømforsyningen (se koblingsskjema i vedlegg).
- 3) Slå på filtreringspumpen.
- 4) Se til at alle vannventiler er åpne og at vannet renner inn i enheten før varme eller avkjøling skrur på.
- 5) Sjekk at kondensutløpet er festet riktig og er fri for blokkeringer.
- 6) Aktiver enhetens strømforsyning og trykk på On/Off-knappen  på kontrollpanelet.

3. INSTALLERING OG TILKOBLING (fortsetter)

- 7) Se til at ingen alarm- eller låsesymboler vises. Dersom det motsatte skulle være tilfellet, se veiledningen for feilsøking (se § 6.4).
- 8) Fastsett vannstrømmen ved hjelp av bypassventilen (se kapittel 2.1 og 4.2), som angitt for hver modell, slik at du oppnår en temperaturforskjell på 2°C mellom vanninnløp og vannutløp.
- 9) Etter den har stått på noen minutter, sjekk at luften som kommer ut av enheten er kjøligere (mellom 5°C-10°C).
- 10) Slå av filtreringspumpen mens enheten er i drift. Enheten skrur også av automatisk og viser feilkoden E03 (Se kapittel 6.4).
- 11) La enheten og filtreringspumpen stå på hele døgnet helt til ønsket vanntemperatur er nådd. Enheten slås av når gitt temperatur for vanninnløp er nådd. Enheten vil nå automatisk restarte (så lenge filtreringspumpen er på) når vanntemperaturen blir 2°C mindre enn angitt temperatur.

Vannsirkulasjonsbryter - Enheten er utstyrt med en bryter som aktiverer varmpumpen når filtreringspumpen er på, og skrur den av når pumpen skrur av. Ved mangel på vann, vises alarmkoden E03 på kontrolleren (Se kapittel 6.4).

Tidsforsinkelse - enheten er utstyrt med en innebygd 3-minutters omstartsforsinkelse for å beskytte kontrollkretsens deler og for å fjerne omstartssyklus og støy. Denne tidsforsinkelsen vil automatisk omstarte enheten ca. 3 minutter etter hver avbrytelse av kontrollkretsen. Selv et kort strømavbrudd vil aktivere tidsforsinkelsen og forhindre enheten fra å starte før nedtellingen på 3 minutter er over.

4. BRUKERGRENSESNITT (forts.)

OFF/STANS-modus

Når varmpumpe står i stanby-modus (OFF modus), vil det stå OFF på regulatorens skjerm, og displayet vil gå over i sparemodus etter ett minutt.

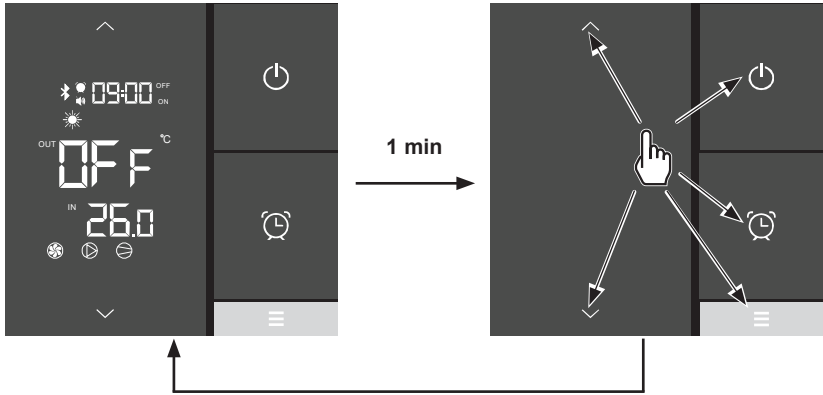

For å komme tilbake til full visning, må du trykke på hvilken som helst knapp.

ON Modus

Når varmpumpen er i bruk eller i reguleringsmodus (ON modus), vil inngangs- og utgangstemperaturene for vannet vises på regulatorens skjerm, og displayet vil gå over i sparemodus etter ett minutt.

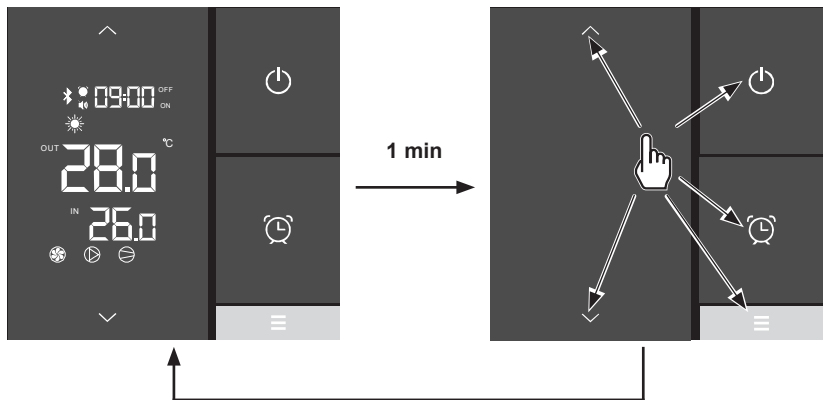

For å komme tilbake til full visning, må du trykke på hvilken som helst knapp.

4. BRUKERGRENSESNITT (forts.)

4.2 Justering av vannmengden

Mens inngangs- og utgangsentilene er åpne, må du stille “by-pass” ventilen slik at du får en temperaturforskjell på 2°C mellom inngående og utgående vann (se prinsippskjemaet § 3.1).

Du kan sjekke innstillingen ved å lese direkte på betjeningspanelet inngangs- og utgangstemperaturene. Følg nedenstående prosedyre.



Still inn din By-pass slik at du får en temperaturforskjell på 2°C mellom inngangen og utgangen.

Trykk på  for å komme ut av menyen.

- Jo mer du åpner “by-pass” ventilen, desto mindre blir flyten i varmpumpens veksler. Derfor vil forskjellen mellom inngående og utgående temperatur øke.
- Jo mer du stenger igjen “by-pass” ventilen, desto større blir flyten i varmpumpens veksler. Derfor vil forskjellen mellom inngående og utgående temperatur minke.

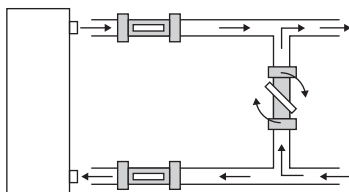









Du kan sjekke innstillingen ved å visualisere inngangs/ utgangstemperaturene (1-2) direkte på appen “EyesPool Inverter Connect” (se § 4.6).



4. BRUKERGRENSESNITT (forts.)

4.3 Stilling av klokken

Når du er ferdig med innstillingen, trykker du på  for å lagre. Lagring av innstillingene skjer automatisk etter 5 sekunders inaktivitet.













- Trykk på  klokkeslettet begynner å blinke.
- Trykk på  timene begynner å blinke. Still timetallet ved hjelp av knappene  og .
- Trykk på  og still minuttene ved hjelp av knappene  og .
- Bekreft ved å trykke på .

4.4 Stille inn timerne Av/På

Denne funksjonen må stilles inn når du ønsker å sette varmpumpen i drift over en kortere periode enn den som er definert av filtreringstimeren. På denne måten kan du programmere en senere start eller en tidligere stans, eller ganske enkelt utelukke et tidsintervall (for eksempel om natten).

Du har muligheten til å stille inn en Start timer (ON) og en Stopp timer (OFF).

Programmere Start-timeren (ON)

- Trykk på  i 2 sekunder til ikonet  begynner å blinke.
- Trykk på , feltet  begynner å blinke (.
- Trykk på  for å stille timene ved hjelp av knappene  og .
- Trykk på  for å stille minuttene ved hjelp av knappene  og .
- Bekreft ved å trykke  og så på  for å komme tilbake til hovedskjermen.

















Innstillingene lagres automatisk etter 20 sekunders inaktivitet.

Innstillingen av minuttene gjøres med 10 minutters trinn

Benevnelsen ON under klokkeslettet på hovedskjermen indikerer at Start-timeren (ON) er programmert.

4. BRUKERGRENSESNITT (forts.)

Programmere Stopp-timeren (OFF)







- Trykk på  i 2 sekunder til ikonet  begynner å blinke
- Trykk på , feltet  begynner å blinke().
- Trykk på , feltet  begynner å blinke().
- Trykk på  for å stille timene ved hjelp av knappene  og .
- Trykk på  for å stille minuttene ved hjelp av knappene  og .
- Bekreft ved å trykke  og så på  for å komme tilbake til hovedskjermen.

Innstillingene lagres automatisk etter 20 sekunders inaktivitet.

Innstillingen av minuttene gjøres med 10 minutters trinn







Benevnelsen OFF over klokkeslettet på hovedskjermen indikerer at Stopp-timeren (OFF) er programmert.

Lese timerne







- Trykk på  i 2 sekunder til ikonet  begynner å blinke.
- Trykk på , start-klokkeslettet  begynner å blinke.
- Trykk på , slutt-klokkesettet  begynner å blinke.
- Trykk på  for å komme tilbake til hovedskjermen.

Ikonet  vises på hovedskjermen så snart du har programmert en Start-timer og/eller en Stopp-timer.

Slette Start (ON) og Stopp (OFF) timere











- Trykk på  i 2 sekunder til ikonet  begynner å blinke.
- Trykk 2 ganger på , klokkeslettene for oppstart blinker .
- Trykk på  for å slette Start-timeren .

Når du er ferdig med trinn 3, trykker du på  for å komme tilbake til hovedskjermen, eller du går videre til trinn 4 for å fortsette.

- Trykk på  for å komme til stoppe-tiden .
- Trykk på , klokkeslettene for stansing blinker .
- Trykk på  for å slette Stopp-timeren .
- Trykk på  for å komme tilbake til hovedskjermen.

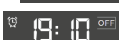
4. BRUKERGRENSESNITT (forts.)

















Slette Stopp-timeren (OFF)

- Trykk på  i 2 sekunder til ikonet  begynner å blinke.
- Trykk 2 ganger på , klokkeslettene for oppstart blinker .
- Trykk på  for å komme til stoppe-klokkeslettet .
- Trykk på  klokkeslettene for stansing blinker .
- Trykk på  for å slette Stopp-timeren .
- Trykk på  for å komme tilbake til hovedskjermen.











4.5 Stille inn Timer-funksjon i SILENCE-modus

I SILENCE-modus kan du bruke varmpumpen i økonomisk modus, på lavt lydnivå, dersom oppvarmingsbehovet ikke er sterkt (hvis vanntemperaturen kun skal holdes jevn, eller hvis du trenger å ha stillegående drift).

Programmering av timeren i SILENCE-modus

- Trykk på  i 2 sekunder, til ikonet  begynner å blinke.
- Trykk på , ikonet  begynner å blinke.
- Trykk på , feltet  vil blinke.
- Trykk på  for å stille oppstartstiden ved hjelp av knappene  og .
- Trykk på  og på  feltet  vil blinke.
- Trykk på  for å stille stoppetiden ved hjelp av knappene  og .
- Trykk på  for å lagre, og på  for å komme tilbake til hovedskjermen.

Slette timeren i SILENCE-modus







- Trykk på  i 2 sekunder, til ikonet  begynner å blinke.
- Trykk på , ikonet  begynner å blinke.
- Trykk på , start-klokkeslettet  begynner å blinke.
- Trykk på  kun timene vil blinke.
- Trykk på , feltet  vil blinke.
- Trykk på  for å komme tilbake til hovedskjermen.

Sletter du Start-timeren, vil Stopp-timeren slettes automatisk ved samme anledning.

Justeringstrinnet er fra "time til time".

4. BRUKERGRENSESNITT (forts.)

Lese timeren i SILENCE-modus

- Trykk på  i 2 sekunder, til ikonet  begynner å blinke.
- Trykk på , ikonet  begynner å blinke.
- Trykk på  for å se Start-klokkeslettet.
- Trykk på  for å se Stoppe-klokkeslettet.
- Trykk på  for å komme tilbake til hovedskjermen.

Når ikonet  vises på hovedskjermen, betyr det at det er programmert en Start-timer og/eller en Stopp-timer i SILENCE-modus.

4.6 Bluetooth paring - Fjernkontroll

Varmepumpen er utstyrt med en Bluetooth-funksjon.

Ved hjelp av appen “*EyesPool Inverter Connect*” kan du bruke din smarttelefon som fjernkontroll for å betjene varmpumpen din på en avstand på 10 m i fritt område.

Hvis du ønsker å bruke denne funksjonen  **Bluetooth**:

- ▶ Last ned appen “*EyesPool Inverter Connect*” gratis på  eller



- ▶ Opprette en konto i appen.
- ▶ Følg instruksene i videoen (se nedenstående lenker) for å pare smarttelefonen din med varmpumpen:
<https://www.hayward.fr/article/tutoriels-hayward/s-line-pro-bluetooth-appairage>



4. BRUKERGRENSESNITT (forts.)

4.7 Velge driftsmodusen

Oppvarming - Automatisk - Nedkjøling



Hvis installatøren har stilt inn varmepumpen slik at den kun kan varme eller kun kjøle ned, vil du ikke kunne endre modusen.

Trykk på tasten  for å bytte modus: Oppvarming - Automatisk - Nedkjøling.

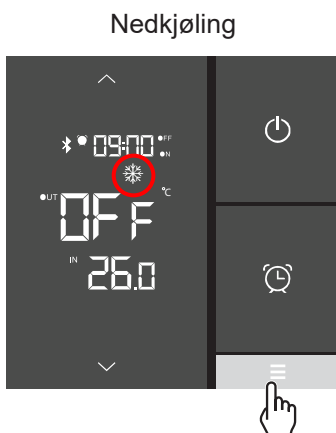
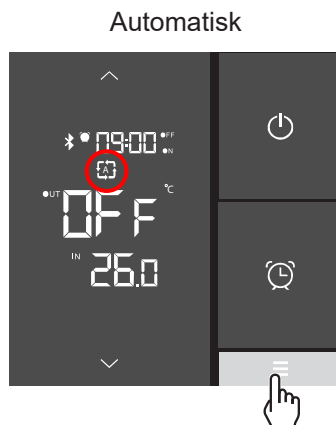
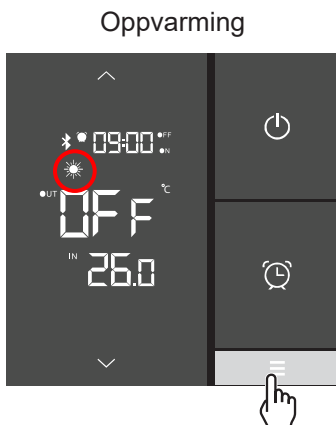





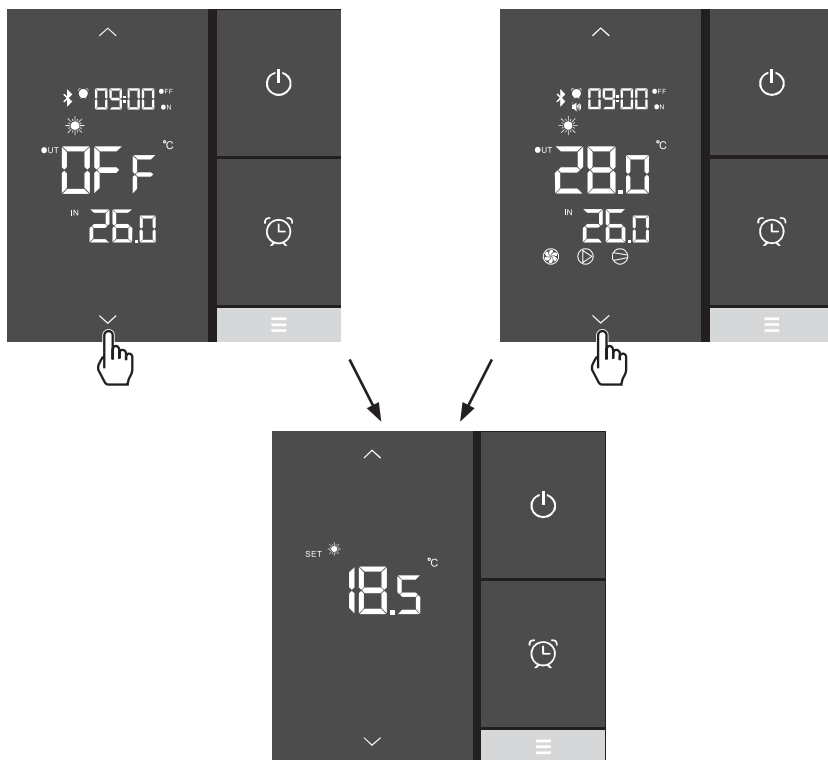

4. BRUKERGRENSESNITT (forts.)

4.8 Innstilling og visning av settpunktet

Ønsket vanntemperatur

Innstilling av settpunktet kan gjøres enten i OFF-modus eller i ON-modus, med en presisjon på 0,5°C.



- Trykk på  eller  for å få settpunktet til å blinke.
- Trykk på  eller  for å definere settpunktet du ønsker.
- Trykk på  for å bekrefte eller på  for å angre.

Lagring av innstillingen skjer automatisk etter 5 sekunders inaktivitet.







Det anbefales å ikke overskride temperatur på 30°C for ikke å skade bassengduken.

4. BRUKERGRENSESNI TT (forts.)

4.9 Låsing og opplåsing av berøringsskjermen

Låsing og opplåsing av skjermen kan gjøres enten i OFF-modus eller i ON-modus.

- Trykk på  i 5 sekunder til du ser ikonet .
- For å låse opp, trykker du på  til ikonet  blir borte.

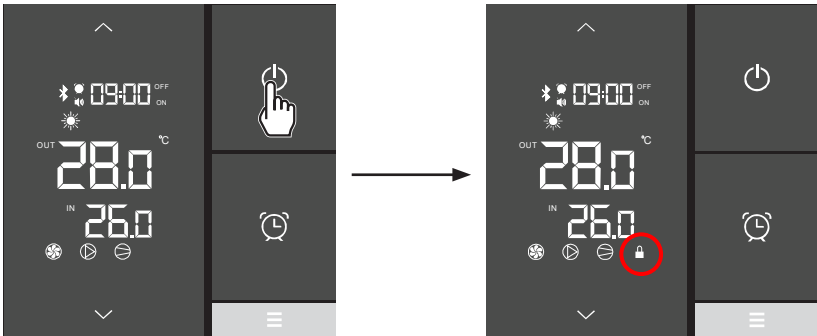

5. VEDLIKEHOLD OG VINTERKLARGJØRING

5.1 Vedlikehold

Disse vedlikeholdsoperasjonene må utføres en gang i året for å sikre lang levetid og god drift av varmpumpen.

- Rengjør fordampere med en myk børste eller med en luft- eller vannstråle (**NB! Bruk aldri høytrykksspyler**).
- Kontroller evakuering av kondensat.
- Kontroller at elektriske og hydrauliske koblinger sitter godt
- Kontroller vanntettheten til kondensatoren.
- La en kvalifisert fagmann sjekke tettheten på kjølekretsen ved hjelp av en lekkasje-detektor.



Før alt vedlikehold må varmpumpen være frakoblet alle strømkilder. Vedlikeholdsoperasjoner skal bare utføres av personell som er kvalifisert til å håndtere kuldemedier.

5.2 Vinterklargjøring

- Sett varmpumpen i "OFF"-modus.
- Slå av varmpumpens strømforsyning.
- Tøm kondensatoren ved hjelp av tømmeventilen for å unngå fare for degradering. (høy risiko for frost).
- Lukk bypassventilen og skru løs koblingsdelene til vanninnløp/vannutløp.
- Fjern maksimalt med stillestående vann som er igjen i kondensatoren ved hjelp av en blåsepistol.
- Forsegle varmpumpens vanninnløp og vannutløp for å hindre at fremmedlegemer kommer seg inn.
- Dekk til varmpumpen med vinterbelegget som er tiltenkt dette formålet.



Alle skader som er forårsaket av uriktig vinterklargjøring vil ugyldiggjøre garantien.

6. VEDLEGG

6.1 Koblingskjemaer

HP5081DT3LVM / HP5111DT3LV

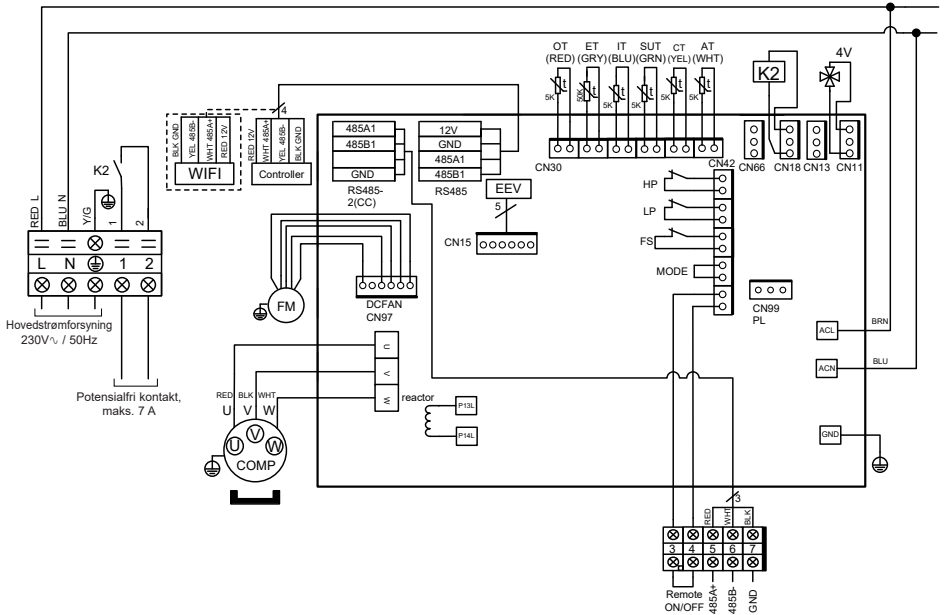

MERKNADER

- | | |
|---|---|
| AT : SENSOR FOR LUFFTEMPERATUR | LP : LAVTRYKKSBRUYTER |
| COMP : KOMPRESSOR | OT : TEMPERATURSENSOR TIL VANNUTLØP |
| CT : SENSOR FOR FORDAMPET TEMPERATUR | SUT : SENSOR FOR SUGETEMPERATUR |
| EEV : ELEKTRONISK EKSPANSJONSVENTIL | 4V : 4-VEIS VENTIL |
| FM : VIFTEMØTOR | K2 : POTENSIALFRI KONTAKT, MAKS. 7 A |
| FS : VANNSENSOR | ET : TEMPERATURSENSOR FOR UTLADNING |
| HP : HØYTRYKKSBRUYTER | OPSJON |
| IT : TEMPERATURSENSOR TIL VANNINNLØP | |

6. VEDLEGG (fortsetter)

HP5151DT3LV

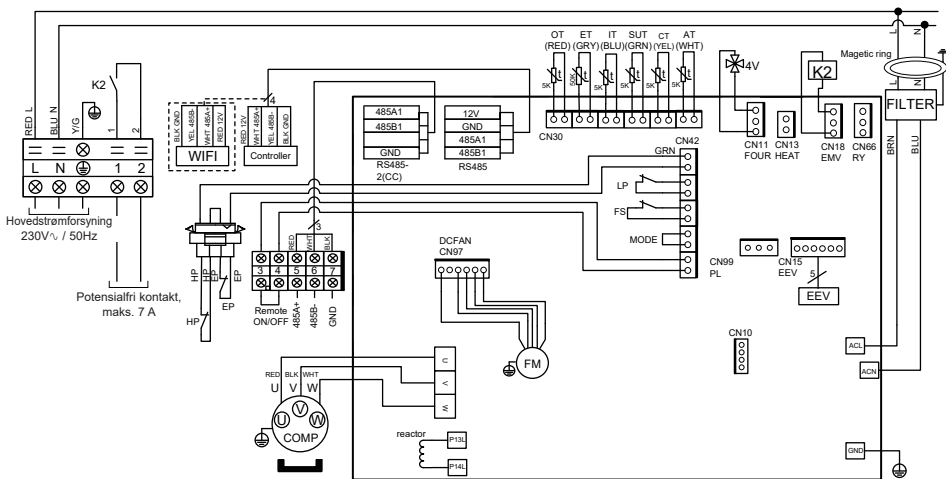

MERKNADER

- | | |
|---|---|
| AT : SENSOR FOR LUFTEMperatur | LP : LAVTRYKKSBRyTER |
| COMP : KOMPRESSOR | OT : TEMPERATURSENSOR TIL VANNUTLØP |
| CT : SENSOR FOR FORDAMPET TEMperatur | SUT : SENSOR FOR SUGETEMperatur |
| EEV : ELEKTRONISK EKSPANSJONSVENTIL | 4V : 4-VEIS VENTIL |
| FM : VIFTEMOTOR | K2 : POTENSIALFRI KONTAKT, MAKS. 7 A |
| FS : VANNSENSOR | ET : TEMPERATURSENSOR FOR UTLADNING |
| HP : HØYTRYKKSBRyTER | OPSJON : OPSJON |
| IT : TEMPERATURSENSOR TIL VANNINNLØP | |

6. VEDLEGG (fortsetter)

6.2 Kobling med prioritet på enfaset varmepumpe

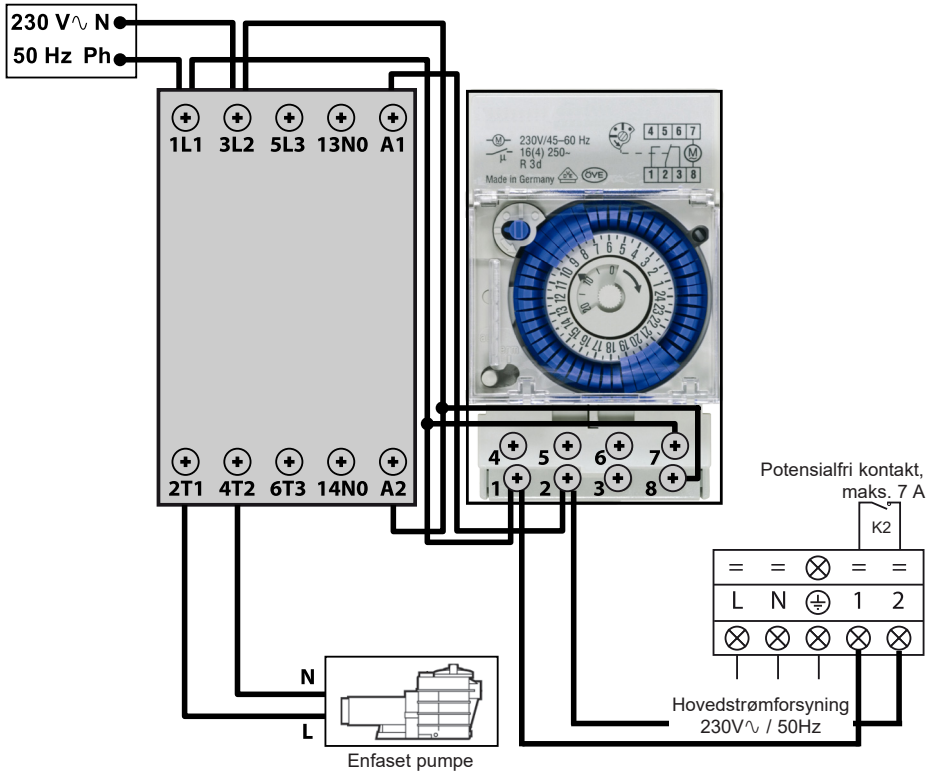

“Terminalene 1 og 2 gir et tørt kontaktpotensial uten polaritet 230 V~/ 50 Hz.

Kabling til klemmene 1 og 2 i samsvar med ledningene beskrevet ovenfor, for å kontrollere driften av pumpen ved filtrering syklus 2 min hver time hvis temperaturen i tanken er under det innstilte punktet. “



Aldri koble strømtilførselen til filterpumpen direkte på terminalene 1 og 2.

6. VEDLEGG (fortsetter)

6.3 Sprengskisse og reservedeler

HP5081DT3LV / HP5111DT3LV / HP5151DT3LV

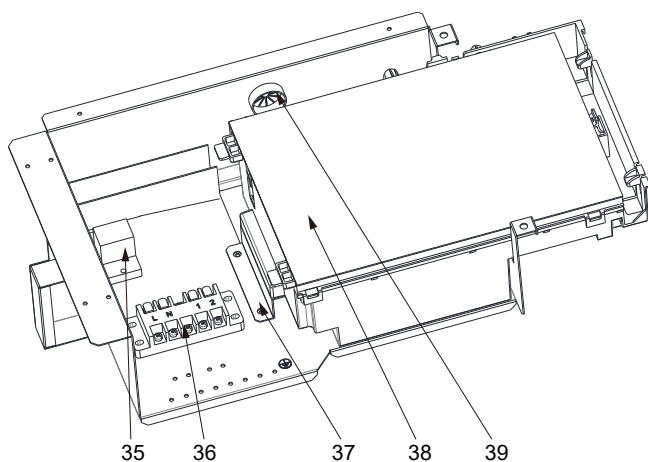
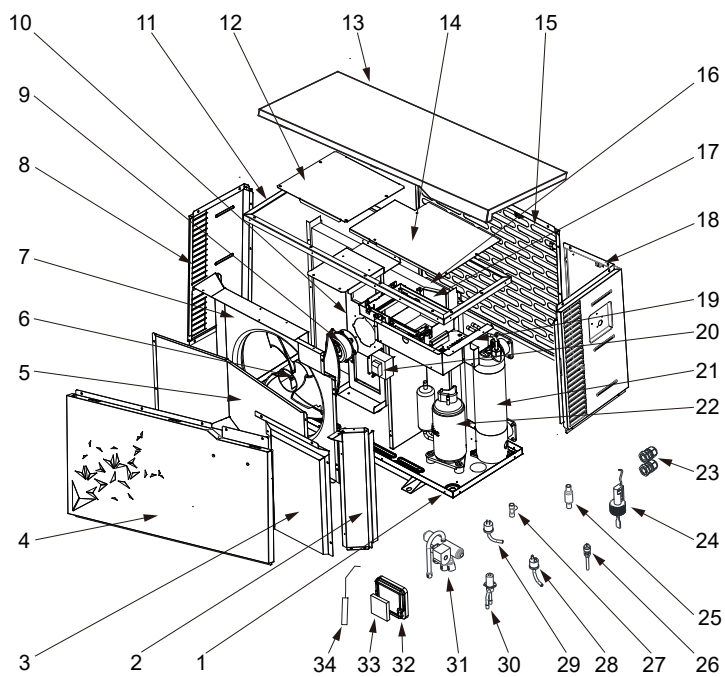

6. VEDLEGG (fortsetter)

Nr.	Betegnelse	Ref.	HP5081DT3LV	HP5111DT3LV	HP5151DT3LV
1	/	/	/	/	/
2	/	/	/	/	/
3	/	/	/	/	/
4	Fremre panel	HWX80715842	✓	✓	Gjelder ikke
		HWX80715857	Gjelder ikke	Gjelder ikke	✓
5	/	/	/	/	/
6	Vifteproprell	HWX301030000006	✓	✓	Gjelder ikke
		HWX20000270004	Gjelder ikke	Gjelder ikke	✓
7	/	/	/	/	/
8	Venstre panel	HWX80713420	✓	✓	Gjelder ikke
		HWX80713423	Gjelder ikke	Gjelder ikke	✓
9	Viftemotor DC	HWX80200018	✓	✓	Gjelder ikke
		HWX20000330132	Gjelder ikke	Gjelder ikke	✓
10	Motorstøtte	HWX80708597	✓	✓	Gjelder ikke
		HWX80709977	Gjelder ikke	Gjelder ikke	✓
11	/	/	/	/	/
12	/	/	/	/	/
13	Øvre panel	HWX80708601	✓	✓	Gjelder ikke
		HWX80709984	Gjelder ikke	Gjelder ikke	✓
14	/	/	/	/	/
15	Bakpanel	HWX80710829	✓	✓	Gjelder ikke
		HWX80710966	Gjelder ikke	Gjelder ikke	✓
16	Vinget fordampner	HWX80600849	✓	Gjelder ikke	Gjelder ikke
		HWX80600781	Gjelder ikke	✓	Gjelder ikke
		HWX80600835	Gjelder ikke	Gjelder ikke	✓
17	/	/	/	/	/
18	Høyre panel	HWX80713421	✓	✓	Gjelder ikke
		HWX80713424	Gjelder ikke	Gjelder ikke	✓
19	/	/	/	/	/
20	Reaktans	HWX82500020	✓	✓	Gjelder ikke
		HWX82500021	Gjelder ikke	Gjelder ikke	✓
21	Kondensator Titanium/PVC	HWX80600939	✓	Gjelder ikke	Gjelder ikke
		HWX80600940	Gjelder ikke	✓	✓
		HWX80600096	Gjelder ikke	Gjelder ikke	✓
22	Kompressor	HWX20000110448	✓	✓	Gjelder ikke
		HWX80100046	Gjelder ikke	Gjelder ikke	✓
23	Kabelmuffe	HWX20012249	✓	✓	Gjelder ikke
		HWX20012238	Gjelder ikke	Gjelder ikke	✓
24	Sensor for vannstrømning	HWX83000068	✓	✓	✓
25	Filter Ø9.7-Ø9.7 (Ø19)	HWX20000140178	✓	✓	Gjelder ikke
	Filter Ø9.7-Ø9.7 (Ø28)	HWX20041444	Gjelder ikke	Gjelder ikke	✓
26	Tryktilkobling 40mm-1/2"	HWX20000140150	✓	✓	✓
27	T-formet connector Ø9.52-2 x Ø6.35(T) x 1.0	HWX30403000002	✓	✓	Gjelder ikke
	T-formet connector Ø6.5-2 x Ø6.5(T) x 0.75	HWX20001460	Gjelder ikke	Gjelder ikke	✓
28	Strømningsbegrenser NO 0.30MPa/0.15MPa	HWX20000360157	✓	✓	✓
29	Høytrykkspressostat NC 3.2MPa/4.4MPa	HWX20013605	✓	✓	✓
30	Elektronisk ekspansjonsventil	HWX81000011	✓	✓	Gjelder ikke
		HWX81000017	Gjelder ikke	Gjelder ikke	✓
31	4-veisventil	HWX20041437	✓	✓	Gjelder ikke
		HWX20000140485	Gjelder ikke	Gjelder ikke	✓
32	Holder for kontroller	HWX80901004	✓	✓	✓
33	Bluetooth LCD-kontroller	HWX72200312	✓	✓	✓

6. VEDLEGG (fortsetter)

HP5081DT3LV / HP5111DT3LV / HP5151DT3LV

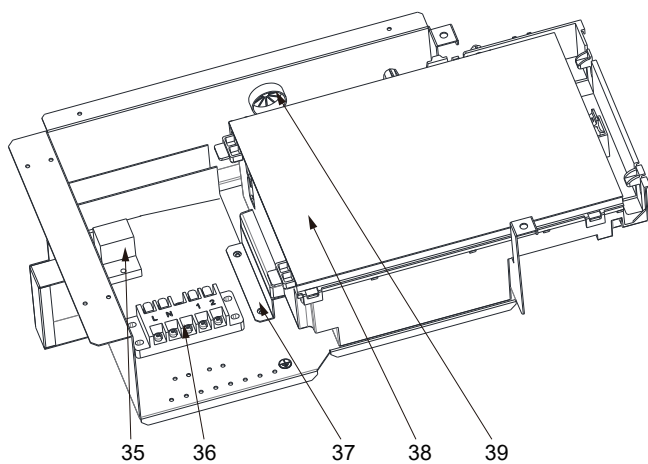
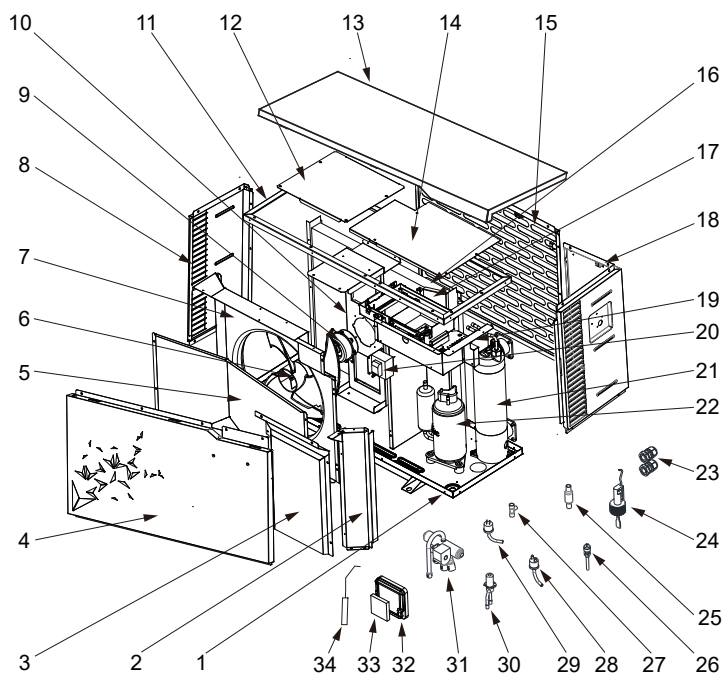

6. VEDLEGG (fortsetter)

Nr.	Betegnelse	Ref.	HP5081DT3LV	HP5111DT3LV	HP5151DT3LV
34	Vannuttak probe 5k-410mm	HWX83000050	✓	✓	✓
	Vanninntak probe 5k-850mm	HWX83000052	✓	✓	✓
	Kompressorutladningssonde 50k-660mm	HWX83000026	✓	✓	✓
	Kompressorsugesonde 5k-560mm	HWX83000044	✓	✓	Gjelder ikke
	Kompressorsugesonde 5k-760mm	HWX83000053	Gjelder ikke	Gjelder ikke	✓
	Avrimings sensor 5k-680mm	HWX83000051	✓	✓	Gjelder ikke
	Avrimings sensor 5k-1040mm	HWX83000045	Gjelder ikke	Gjelder ikke	✓
	Lufttemperatur probe 5k-350mm	HWX83000049	✓	✓	✓
35	Relé K2	HWX20000360297	✓	✓	✓
36	Terminal L-N-GND -5 tilkoplinger 4mm ²	HWX40003901	✓	✓	✓
37	/	/	/	/	/
38	Elektronisk Driver-kort	HWX72200168SL08	✓	Gjelder ikke	Gjelder ikke
		HWX72200168SL11	Gjelder ikke	✓	Gjelder ikke
		HWX72200168SL15	Gjelder ikke	Gjelder ikke	✓
39	/	/	/	/	/

6. VEDLEGG (fortsettelse)

6.4 Service-manual



Enkelte inngrep må utføres av en kvalifisert tekniker.

I tilfelle feil, vil følgende meldinger vises på skjermen:

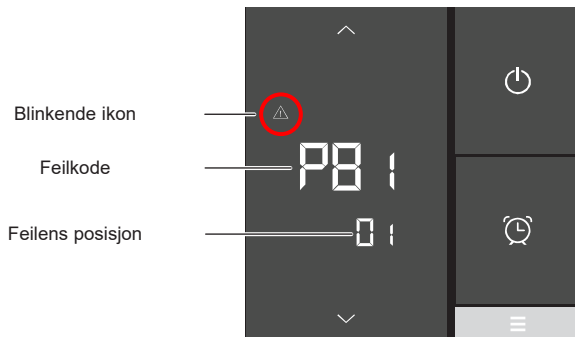

Hvis det oppstår feil, trykk på  eller  for å bla fra den ene feilkoden til neste.

Se tabellen lenger ned.



Etter at feilen er opphevet, vil den fjernes automatisk og trekanten vil forsvinne.

6. VEDLEGG (fortsettelse)

Feilfunksjon	Feilkoder	Beskrivelse	Løsning
Feil ved sensor for inngående vann (IT)	P01	Sensoren er åpen eller det er en kortslutning	Sjekk koblingen på forlenger-koblingen eller bytt sensor
Feil ved sensor for utgående vann (OT)	P02		
Feil ved utvendig temperatur-sensor (AT)	P04		
Feil med opptiningssonden (CT)	P05		
Feil med aspirasjonssonden på kompressoren (SUT)	P07		
Feil med tilbakeslagsensoren på kompressoren (ET)	P08 1		
Feil Høytrykk	E01	Sensoren er åpen eller det er en kortslutning	Sjekk koblingen på forlenger-koblingen eller bytt sensor
			Sjekk vannmengden
			Sjekk detektoren for vannmengde
			Sjekk at ventilene er åpne
			Sjekk by-passventilen
			Sjekk at fordampere ikke er tett
			Vanntemperaturen er for høy
			Kondensproblemer etter vedlikeholdsarbeid, tøm hele kjølekretsen
For stor væskemengde, tøm noe væske ut i en flaske			
Feil Lavtrykk	E02	Sensoren er åpen eller det er en kortslutning	Sjekk koblingen på forlenger-koblingen eller bytt sensor
			Stor lekkasje med kjølevæske, foreta en lekkasjetest med detektor
			Luftmengden er for lav, sjekk hastigheten til viferotasjonen
			Sjekk at fordampere ikke er tett, rengjør den på overflaten

6. VEDLEGG (fortsettelse)

Feilfunksjon	Feilkoder	Beskrivelse	Løsning
Feil med detektoren for vannmengden	E03	Sensoren er åpen eller det er en kortslutning	Sjekk koblingen CN29/OVT på kortet eller bytt sensor
			Ikke nok vann, sjekk filteringspumpens drift
			Sjekk at vannkranene er åpne
			Sjekk at by-passventilen er justert ordentlig
Temperaturforskjellen mellom Innløp og Utløp >13°C	E05	Gjelder kun Kald-Modus	Ikke nok vann, sjekk filteringspumpens drift
			Sjekk at vannkranene er åpne
			Sjekk at by-passventilen er justert ordentlig
Frostvæske	E07	Temperatur for utgående vann < 4°C	Stans varmepumpen, tøm kondensatoren, fare for frost
Kommunikasjonsproblem	E08	Ingen kommunikasjon mellom det elektroniske kortet og brukergrensesnittet	Sjekk koblingene og kontaktene, se strømskjemaet
Frostvæskeniå 1	E19	2°C < Vanntemperatur < 4°C og lufttemperatur < 0°C	Stans varmepumpen, tøm kondensatoren for å unngå frost. Hvis ikke annet er angitt, vil varmepumpen starte filteringspumpen for at ikke vannet skal fryse
Frostvæskeniå 2	E29	Vanntemperaturen < 2°C og lufttemperaturen < 0°C	Stans varmepumpen, tøm kondensatoren, for å unngå frost. Hvis ikke annet er angitt, vil varmepumpen starte filteringspumpen og varmepumpen for at ikke vannet skal fryse.
Feil med viftemotoren	F03 I	Motoren er låst eller det er en feilkobling	Sjekk fri rotasjon; sjekk koblingen CN97/DCFan; bytt motoren
Feil med viftemotoren	F05 I	Feil med koblingen	Sjekk koblingen DCFAN/CN97; bytt motoren
Utendørstemperaturen er for lav	tP	Driftsgrensen er nådd	Stans varmepumpen
Varmepumpen vil ikke starte	- - - OFF	Kontakt (5-6) Remote On/Off Åpen	Lukk igjen kontakten (5-6) Remote On/Off (se det elektriske skjemaet)

6. VEDLEGG (fortsetter)

6.5 Garanti

GARANTIBETINGELSER

HAYWARD garanterer at deres produkter er fri for defekter i materiale og i utførelse for en periode på to år fra innkjøpsdato. Ved evt. garantikrav, må kvittering for kjøpet fremlegges. Vi ber om at kvitteringen blir tatt vare på av kjøper.

HAYWARD garanti er, etter HAYWARD eget valg, begrenset til erstatning eller reparasjon av defekte produkter som har vært i normal bruk og behandlet i henhold til instruksjonsboken, uten at det har vært foretatt endringer av produktet, og at bare ekte HAYWARD deler har vært brukt. Skader som skyldes frost og kjemiske reaksjoner er ikke omfattet av denne garanti.

HAYWARD er ikke ansvarlig for noen andre kostnader (flytting, arbeidskostnader osv...), heller ikke for direkte eller indirekte skader som skyldes funksjonsfeil ved et produkt.

For å sette i gang et garantikrav og å be om reparasjon eller erstatning av et produkt, vennligst ta kontakt med forhandleren. Forsendelse av produkter direkte til vår fabrikk blir ikke akseptert uten vår skriftlige forhåndsgodkjenning.

Slitasjedeler omfattes ikke av garantien.

Denne siden er blank med hensikt



S.Line Pro *Fi*

VÄRMEPUMP FÖR BASSÄNG



Bruksanvisning och installationsmanual

SAMMANFATTNING

1. FÖRORD	1
2. TEKNISKA EGENSKAPER	4
2.1 Tekniska data för värmepumpen	4
2.2 Driftintervall	5
2.3 Dimensioner	6
3. INSTALLATION OCH ANSLUTNING	7
3.1 Principschema	7
3.2 Värmepump	7
3.3 Hydraulisk anslutning	8
3.4 Elektrisk anslutning	9
3.5 Första starten	10
4. ANVÄNDARGRÄNSSNITT	12
4.1 Allmän presentation	12
4.2 Justering av vattenflöde	14
4.3 Inställning av klocka	15
4.4 Ställa in på/av för timern	15
4.5 Ställa in timerfunktionen i läge TYST	17
4.6 Parkoppling av Bluetooth - Fjärrstyrning	18
4.7 Val av driftläge	19
4.8 Ställ in och visa börvärdet	20
4.9 Låsa och låsa upp pekskärmen	21
5. UNDERHÅLL OCH FÖRBEREDELSE INFÖR VINTERN	22
5.1 Underhåll	22
5.2 Förberedelser inför vintern	22
6. BILAGOR	23
6.1 Kopplingsscheman	23
6.2 Anslutningar för prioritetsuppvärmning av enfaspump	25
6.3 Sprängvyer och reservdelar/addendum	26
6.4 Reparationshandbok	30
6.5 Garanti	33

Ska läsas igenom noga och bevaras för framtida användning.

Detta dokument måste lämnas tillbaka till bassängens ägare och förvaras av denne på ett säkert ställe.

1. FÖRORD

Vi tackar dig för att du har köpt denna värmepump för bassänger från Hayward. Värmepumpen S.LINE PRO är utformad enligt de striktaste tillverkningsstandarderna för att uppfylla de högsta kvalitetskraven.

Värmepumpen S.LINE PRO kommer att erbjuda dig en utmärkt prestanda under hela din badsäsong och tack vare styrprogrammet FULL INVERTER anpassas effekt, elförbrukning och bullernivån enligt din bassängs uppvärmningsbehov.



Läs igenom instruktionerna i denna bruksanvisning noga innan du använder apparaten.

Värmepumpen S.LINE PRO är endast avsedd för att värma upp bassängvatten och du får inte använda denna produkt i något annat syfte.

Denna bruksanvisning innefattar all den information som är nödvändig för installation, åtgärdande av funktionsfel och underhåll.

Läs igenom denna bruksanvisning noga innan du öppnar enheten eller genomför underhållsarbete på den. Tillverkaren av denna produkt kan inte i något fall hållas ansvarig i händelse av att en användare skadas eller en enhet skadas till följd av eventuella fel under installationen, åtgärdande av funktionsfel eller felaktigt underhåll. Det är mycket viktigt att hela tiden följa de instruktioner som anges i denna bruksanvisning.

Om rekommendationerna inte följs gäller inte garantin.

1. FÖRORD (fortsättning)



Säkerhetsinstruktioner



Denna apparat innehåller R32.

Använd aldrig något annat kylmedel än R32. Andra gasformiga ämnen som blandas med R32 kan orsaka onormalt högt tryck, vilket kan leda till haveri eller rörbrott och personsador.

Använd kopparrör som uppfyller standarden EN 12375-1 (maj 2020) och det europeiska direktivet om tryckbärande anordningar 97/23 / EG under reparationer eller underhåll.

Du ska aldrig genomborra eller löda slangar när värmepumpen är trycksatt. Det finns en explosionsrisk.

Se till att apparaten inte utsätts för flammor, gnistor eller andra antändningskällor. Den kan explodera och leda till allvarlig skada eller dödsfall.



Värmepumpen är endast avsedd för installation utomhus.

- Värmepumpen måste förvaras i ett välventilerat utrymme med en golvyta på mer än A_{\min} (m²) med följande formel: $A_{\min} = (M / (2.5 \times 0.22759 \times h_0))^2$
M är kylmedelsladdningen i enheten i kg och h₀ är förvaringshöjden. För förvaring på markhöjd h₀ = 0,6 m.
- Värmepumpen är endast avsedd för installation utomhus.
- Enheten måste installeras av en behörig person.
- Installera inte värmepumpen på ett stöd som riskerar att öka enhetens vibrationer.
- Kontrollera att stödet avsett för enheten är lämpligt anpassat efter enhetens vikt.
- Installera inte värmepumpen på en plats som kan öka bullernivån eller där bullret från enheten kan störa grannarna.
- Alla elektriska anslutningar måste utföras av en behörig elektriker och enligt de standarder som gäller i det land där enheten installeras, se punkt 3.4.
- Koppla bort strömmen innan du utför något elektriskt arbete. Om du inte gör det kan det orsaka en elektrisk stöt.
- Före installationen ska du kontrollera att jordkabeln inte är kapad eller urkopplad. Anslut och dra åt strömkabeln ordentligt. Om anslutningen är dålig kan de elektriska delarna skadas.

1. FÖRORD (fortsättning)

- Om värmepumpen utsätts för vatten eller fukt kan det orsaka elektriska stötar. Var mycket uppmärksam.
- Om du upptäcker fel eller avvikelser, installera inte värmepumpen utan kontakta istället din återförsäljare omgående.
- Underhållet och de olika arbetsstegen måste utföras med den rekommenderade frekvensen och vid de rekommenderade tidpunkterna, såsom anges i denna bruksanvisning.
- Reparationerna måste utföras av en behörig person.
- Använd endast originalreservdelar.
- Tillämpa aldrig någon annan rengöringsprocess än den som rekommenderas i den här bruksanvisningen.

Viktig information gällande använt kylmedel

Denna produkt innehåller fluorerade växthusgaser som omfattas av Kyoto-protokollet. Frigör inte denna gas i atmosfären.

Typ av kylmedel: R32

GWP-värde (1): 675, värde baserat på den 4:e IPCC-rapporten.

Kylmedelsmängd baserad på förordningen (EU) nr 517/2014 anges på enhetens typskylt.

Periodiska inspektioner av kylmedelsläckor kan fordras beroende på den europeiska eller lokala lagstiftningen. Vänligen kontakta din lokale leverantör för mer information.

(1) Potential för övergripande uppvärmning

2. TEKNISKA EGENSKAPER

2.1 Tekniska data för värmepumpen

Modeller	S.LINE PRO	HP5081DT3LV	HP5111DT3LV	HP5151DT3LV
Matningsspänning	V	220V-240V ~ /1ph/50Hz		
Kylmedel	/	R32		
Laddning	kg	0,45	0,50	0,65
Massa i tCO ₂ e	/	0,30	0,34	0,44
Frekvens för läckagekontroll	/	Inget krav, men rekommenderas årligen		
Uppvärmningskapacitet Min–Max ^(a)	kW	2,83 -- 8,16	1,95 -- 10,90	5,27 -- 15,66
Absorberad elektrisk effekt Min–Max ^(a)	kW	0,212 -- 1,19	0,150 -- 1,92	0,457 -- 2,80
Nominell driftström Min–Max ^(a)	A	1,41 -- 5,20	1,05 -- 8,49	2,04 -- 12,28
COP Max–Min ^(a)	/	13,30 -- 6,81	12,92 -- 5,67	11,53 -- 5,59
Uppvärmningskapacitet Min–Max ^(b)	kW	1,77 -- 5,91	1,86 -- 8,40	3,81 -- 11,67
Absorberad elektrisk effekt Min–Max ^(b)	kW	0,31 -- 1,28	0,30 -- 1,83	0,588 -- 2,71
COP Max–Min ^(b)	/	5,70 -- 4,62	6,20 -- 4,59	6,48 -- 4,31
Maximal driftström (CMS)	A	6,50	10,30	14
Säkringens kaliber	gG	10	12	16
Brytare typ C	C	10	12	16
Startström	A	< CMS		
Hydraulisk anslutning	mm	50mm		
Nominellt vattenflöde ^(a)	m ³ /h	3,50	4,60	6,70
Vattnets tryckfall maximalt	kPa	8	5	10
Kompressor	/	DC Inverter MITSUBISHI ELECTRIC		DC Inverter Mitsubishi
Typ	/	Dubbel roterande		
Kvantitet	/	1		
Rullmotstånd vid 20°C	Ohm	1,91 +/- 5%		0,95 +/- 5%
Fläkt	/	Axial		
Kvantitet		1		
Diameter	mm	405		500
Antal blad	/	3		
Motor	/	DC Inverter		
Kvantitet	/	1		
Rotationshastighet	Tr/min	500 -- 800	500 -- 900	500 -- 750
Hastighet i tyst läge	Tr/min	500	500	500
Ljudtrycksnivån vid 1m	dB(A)	45,1	48,6	54,1
Ljudtrycksnivån vid 10m	dB(A)	27,9	31,6	36,9
Enhetens nettdimensioner (L/B/H)	mm	1011 / 430 / 622		1025 / 480 / 768
Vikt	kg	61	61	87



(a) Torr luft 27°C - Relativ fuktighet 78% - Vattnets inloppstemperatur 26 °C.

(b) Torr luft 15°C - Relativ fuktighet 71 % - Vattnets inloppstemperatur 26°C.

2. TEKNISKA EGENSKAPER (fortsättning)

2.2 Driftintervall

Använd värmepumpen inom följande temperatur- och fuktighetsintervall för att säkerställa säker och effektiv funktion.

	Uppvärmningsläge 	Avkylningsläge 
Utomhustemperatur	-7°C – +35°C	+7°C – +43°C
Vattentemperatur	+12°C – +32°C	+8°C – +40°C
Relativ fuktighet	< 80%	< 80%
Inställningsintervall för börvärde	+15°C – +32°C	+8°C – +32°C



Om temperaturen eller fuktigheten inte uppfyller dessa villkor, kan säkerhetsanordningar utlösas och värmepumpen kommer inte längre att kunna fungera.



Den maximala uppvärmningstemperaturen är begränsad till +32°C för att förhindra att bassängens beläggning förstörs. Hayward avsäger sig allt ansvar för användning vid över +32°C.

2. TEKNISKA EGENSKAPER (fortsättning)

2.3 Dimensioner

Modeller:

HP5081DT3LV / HP5111DT3LV / HP5151DT3LV

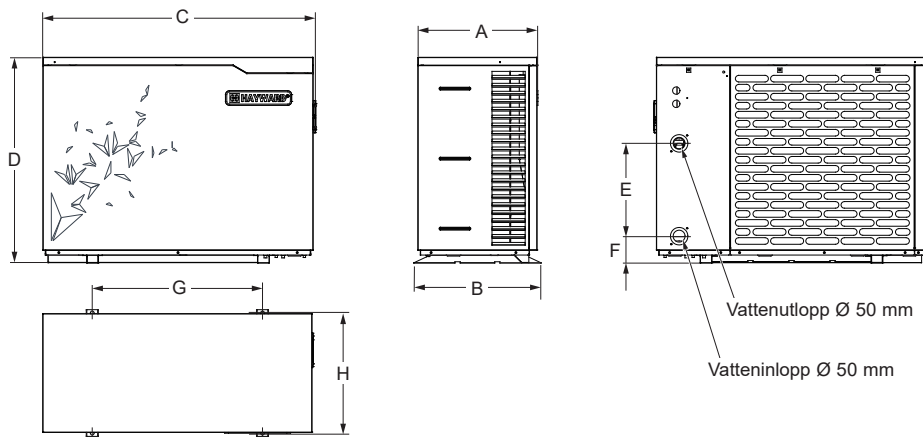

Enhet: mm

Märkning \ Modell	HP5081DT3LV / HP5111DT3LV	HP5151DT3LV
A	393	453
B	430	480
C	1011	1030
D	621,5	776
E	350	350
F	97,5	102
G	625	645
H	406	456

3. INSTALLATION OCH ANSLUTNING

3.1 Principschema

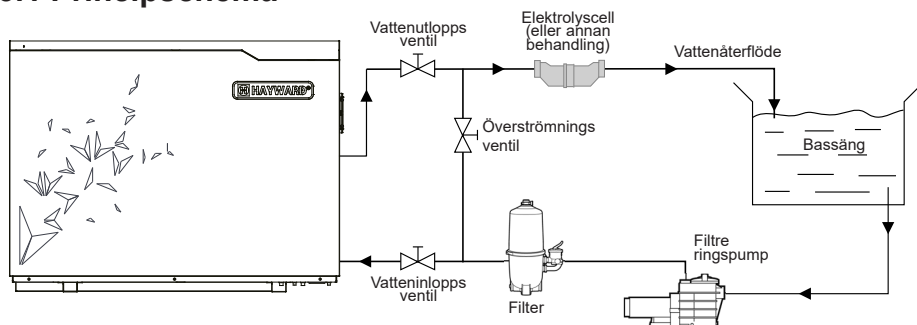

Anmärkning: Värmepumpen levereras utan någon behandlings- eller filtreringsutrustning. Elementen som visas på schemat är delar som installatören måste tillhandahålla.

3.2 Värmepump



Placera varmepumpen på utsidan av och utanför varje tekniskt slutet lokal.

Placera den under ett regnskydd, de nedan beskrivna minimiavstånden måste iakttas för att undvika varje risk för återcirkulering av luft och en försämring av varmepumpens övergripande prestanda.

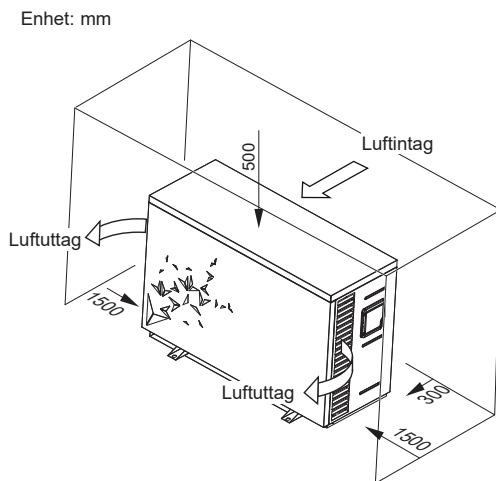

3. INSTALLATION OCH ANSLUTNING (fortsättning)



Installera helst värmepumpen på en avskild betongplatta eller på ett fästfundament som är anordnat i detta syfte och montera värmepumpen på de tillhandahållna ljuddämpningsblocken (skruvar och brickor ingår inte i leveransen).

Det maximala installationsavståndet mellan pumpen och bassängen är 15 meter.

De fram- och återgående hydrauliska rörledningarnas sammanlagda längd blir då 30 meter.

Isolera de hydrauliska rörledningarna som ligger på ytan och dem som är nedgrävda.

Värmepumpen måste installeras med ett minimiavstånd från bassängen enligt NF C 15-100 (3,5 m från vattnet för Frankrike) eller i enlighet med gällande installationsstandarder i andra länder.

Installera inte värmepumpen i närheten av en värmekälla.

Vid installation i områden med mycket snö, är det lämpligt att skydda maskinen för att förhindra att det ansamlas snö på förångaren.

3.3 Hydraulisk anslutning

Värmepumpen är försedd med två skarvanslutningar med en diameter \varnothing på 50 mm. Använd PVC-rör för den hydrauliska rörledningen \varnothing 50 mm. Anslut värmepumpens vatteninlopp till ledningen som kommer från filtreringsenheten och anslut sedan värmepumpens vattenutlopp till vattenledningen som går till bassängen (se schemat nedan).

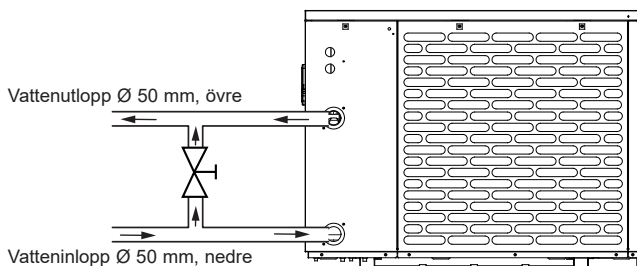

Installera en så kallad "överströmningsventil" mellan värmepumpens in- och utlopp.



Om en automatisk distributör eller elektrolysapparat används, måste den absolut installeras efter värmepumpen i syfte att skydda Titan-kondensorn mot en alltför hög koncentration av kemikalier.



Se till att installera överströmningsventilen och de tillhandahållna skarvanslutningarna ordentligt vid enhetens vatteninlopp och -utlopp, för att göra rensningen lättare under vintersäsongen, underlätta åtkomsten till enheten eller för att göra det lättare att demontera den.

3. INSTALLATION OCH ANSLUTNING (fortsättning)

3.4 Elektrisk anslutning



Den elektriska installeringen av och kabelföringen för denna utrustning måste uppfylla de lokalt gällande reglerna för installering.

F	NF C15-100	GB	BS7671:1992
D	DIN VDE 0100-702	EW	EVHS-HD 384-7-702
A	ÖVE 8001-4-702	H	MSZ 2364-702/1994/MSZ 10-553 1/1990
E	UNE 20460-7-702 1993, RECBT ITC-BT-31 2002	M	MSA HD 384-7-702.S2
IRL	Wiring Rules + IS HD 384-7-702	PL	PN-IEC 60364-7-702:1999
I	CEI 64-8/7	CZ	CSN 33 2000 7-702
LUX	384-7.702 S2	SK	STN 33 2000-7-702
NL	NEN 1010-7-702	SLO	SIST HD 384-7-702.S2
P	RSIUEE	TR	TS IEC 60364-7-702



Kontrollera att den tillgängliga strömförsörjningen och nätets frekvens motsvarar den erforderade driftströmmen, genom att ta hänsyn till apparatens specifika placering och den ström som är nödvändig för att försörja varje annan apparat som är ansluten till samma krets.

HP5081DT3LV / HP5111DT3LV / HP5151DT3LV
230V ~ +/- 10 % 50 Hz 1 fas

Observera det motsvarande kopplingsschemat i bilagan.
Tre anslutningar är avsedda för strömförsörjningen och två för styrning av filtreringspumpen (automatisk återkoppling).

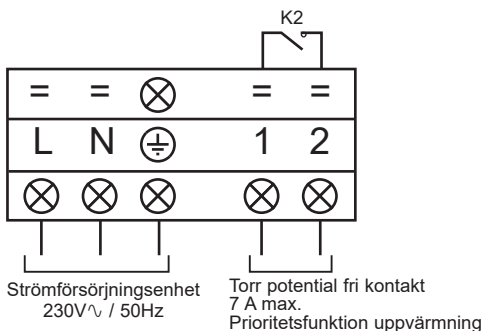

3. INSTALLATION OCH ANSLUTNING (fortsättning)



Strömförsörjningsledningen måste på lämpligt sätt vara försedd med en säkringsskyddsanordning av en strömförsörjartyp till motorn (gG) eller strömbrytare av typ C liksom med en jordfelsbrytare på 30 mA (se tabellen nedan).

Modeller		HP5081DT3LV	HP5111DT3LV	HP5151DT3LV
Strömförsörjning	V/Ph/ Hz	230V~ 50Hz	230V~ 50Hz	230V~ 50Hz
Säkringens amperestyrka typ gG	A	10 gG	12 gG	16 gG
Brytare typ C	A	10 C	12 C	16 C
Kabelsnitt	mm ²	3G 2,5	3G 2,5	3G 2,5



Använd en strömkabel av typen RO2V/R2V eller motsvarande.



Kabelsnitten är för en maximal längd på 25 m, men de måste ändå kontrolleras och anpassas enligt installationsförhållandena.



Se alltid till att stänga av huvudströmförsörjningen innan den elektriska manöverdosan öppnas.

3.5 Första starten

Startprocedur – följ och iakttag följande steg, så snart som installationen avslutats:

- 1) Vrid fläkten för hand för att kontrollera att den kan rotera fritt, och att spiralen är fäst på rätt sätt på motoraxeln.
- 2) Säkerställ att enheten är ansluten på rätt sätt till huvudströmförsörjningen (se kopplingsdiagrammet i bilagan).
- 3) Sätt igång filtreringspumpen.
- 4) Kontrollera att alla vattenventiler är öppna, och att vattnet strömmar mot enheten innan den övergår till uppvärmnings- eller avkylningsläge.
- 5) Kontrollera att röret för tömning av kondensat är fäst på rätt sätt och inte är tilltäppt.
- 6) Slå på strömförsörjningen som är avsedd för enheten, och tryck sedan på knappen Drift/Stop  på manöverpanelen.
- 7) Se till att varken larm- eller låsningssymbolerna visas.
Vid behov, se reparationsvägledningen (se punkt 6.4).

3. INSTALLATION OCH ANSLUTNING (fortsättning)

- 8) Ställ in vattenflödet med hjälp av överströmningsventilen (se punkt 2.1 och 4.2) såsom avsett för varje modell för sig, för att erhålla en temperaturskillnad Inlopp/Utlopp på 2°C.
- 9) Kontrollera efter några minuters drift att luften som strömmar ut från enheten är avkyld (mellan 5°C och 10°C).
- 10) Stäng av filtreringspumpen när enheten är i drift. Enheten ska stanna automatiskt och visa felkoden E03 (se punkt 6.4).
- 11) Håll igång enheten och bassängens pump 24 timmar per dygn tills den önskade vattentemperaturen har uppnåtts. När vattnets inloppstemperatur uppnår börvärdet, stannar enheten. Den återstartar automatiskt (så länge som bassängens pump är i drift) om bassängens temperatur understiger börvärdestemperaturen med minst 0,5°C.

Flödesövervakningsanordning – Enheten är försedd med en flödesövervakningsanordning som sätter igång värmepumpen när bassängens filtreringspump är i drift, och stänger av den när filtreringspumpen inte är i drift. Vid vattenbrist visas varningskoden E03 på inställningsenheten (se punkt 6.4).

Tidsfördröjning – enheten innefattar en tidsfördröjning på 3 minuter, för att skydda styrkretsarnas komponenter, avlägsna varje instabilitet vid återstart och varje störning vid kontakten. Tack vare denna tidsfördröjning, återstartar enheten automatiskt omkring 3 minuter efter varje brytning av styrkretsen. Till och med ett kortvarigt strömavbrott aktiverar fördröjningen av återstarten.

4. ANVÄNDARGRÄNSSNITT

4.1 Allmän presentation

Värmepumpen är utrustad med en digital kontrollpanel med pekskärm, den är elansluten och fabriksinställd på låge värme.

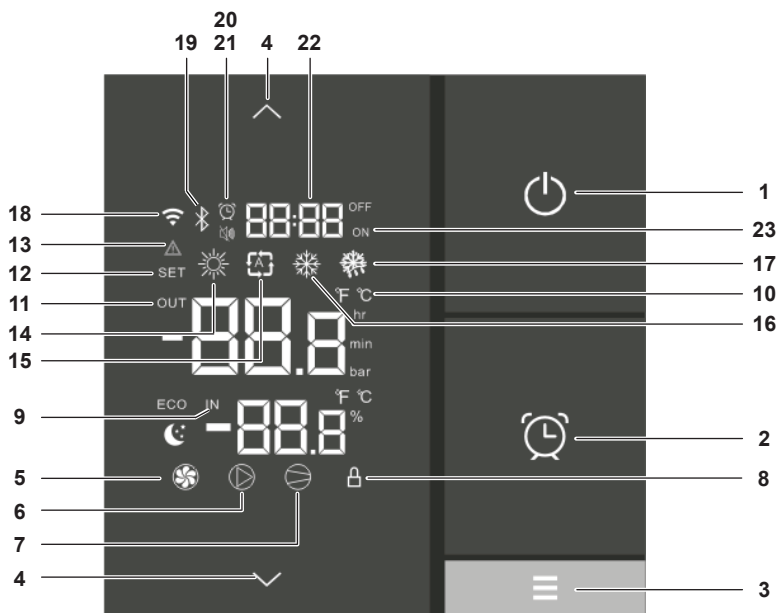

Förklaring

1		På/Av/Annullering
2		Inställning av tid och timer
3		Val av driftläge
4		Bläddra Uppåt/Nedåt, +°C / -°C
5		Fläkt PÅ
6		Kontakt sek UT2 PÅ
7		Kompressor PÅ
8		Låst skärm
9		Vatteninlopp
10		Celsius/Farenheit
11		Vattenutlopp
12		Inställning av avancerade parametrar

13		Fel på system
14		Värme läge
15		Automatiskt läge
16		Kylningsläge
17		Avfrostningsläge
18		Ej tillämpligt
19		Bluetooth-anslutning
20		Inställd timer
21		Indikator för Tyst läge/Timer
22		Tid/Tid för timers
23		Timer inställd på Stopp och Start

4. ANVÄNDARGRÄNSSNITT (forts)

Läge OFF/AV

När värmepumpen är i standbyläge (AV-läge) visas ordet AV på regulatorns skärm och skärmen växlar till energisparande efter en minut.

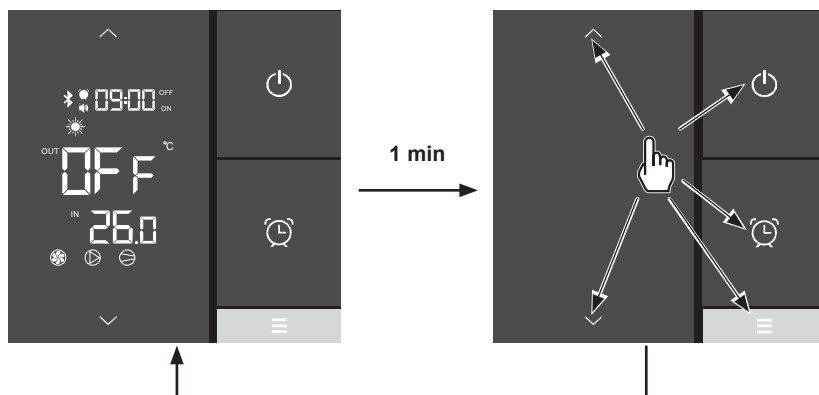

Tryck på valfri knapp för att återgå till komplett skärm.

Läge PÅ

När värmepumpen är i drift eller justeras (PÅ-läge) visas temperaturerna för vatteninlopp och -utlopp på regulatorns skärm och skärmen växlar till energibesparing efter en minut.

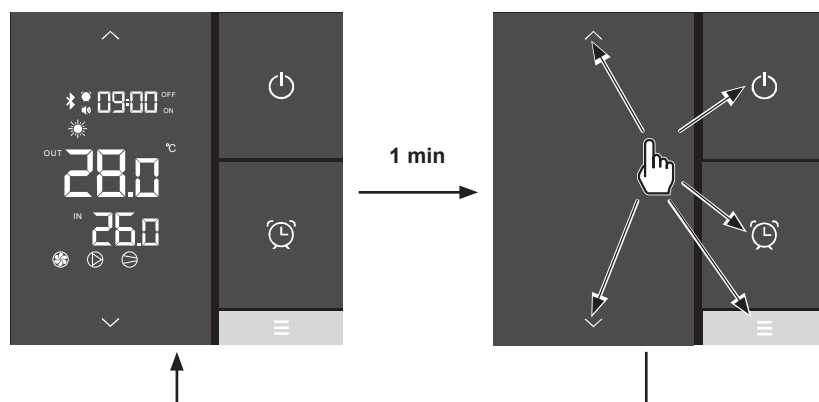

Tryck på valfri knapp för att återgå till komplett skärm.

4. ANVÄNDARGRÄNSSNITT (forts)

4.2 Justering av vattenflöde

Med ventilerna för vatteninlopp och utlopp öppna, justera den så kallade "förbikopplingsventilen" så att en skillnad på 2 °C erhålls mellan temperaturen för vatteninlopp och utlopp (se schematiskt diagram § 3.1).

Du kan kontrollera inställningen genom att gå till temperaturerna för inlopp/utlopp direkt på kontrollpanelen genom att följa proceduren nedan.

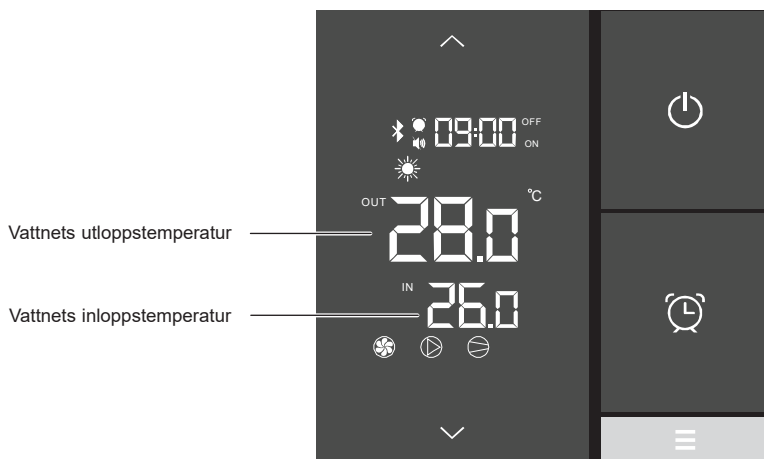

Justera sedan förbikopplingen för att få en skillnad på 2 °C mellan ingången och utgången.

Tryck på  för att lämna meny.

- När "förbikopplingsventilen" öppnas genereras ett svagare flöde i värmepumpens växlare, vilket resulterar i en ökning av temperaturskillnaden för inlopp/utlopp.
- När "förbikopplingsventilen" stängs genereras ett kraftigare flöde i värmepumpens växlare, vilket resulterar i en sänkning av temperaturskillnaden för inlopp/utlopp.

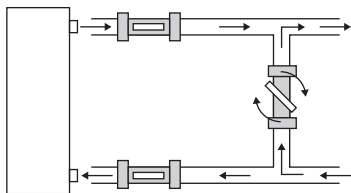









Det är möjligt att kontrollera inställningen genom att gå till temperaturerna för inlopp/utlopp (1-2) direkt på applikationen "EyesPool Inverter Connect" (se § 4.6).

4. ANVÄNDARGRÄNSSNITT (forts)

4.3 Inställning av klocka

När inställningarna gjorts, tryck på  för att bekräfta. Inställningarna sparas automatiskt efter 5 sekunder utan någon åtgärd.













- Tryck på  skärmen för tid blinkar.
- Tryck på  skärmen för timmar blinkar. Ställ in timmarna med knapparna  och .
- Tryck på  ställ sedan in minuterna med knapparna  och .
- Bekräfta genom att trycka på .

4.4 Ställa in på/av för timern

Det är nödvändigt att ställa in denna funktion när du vill använda värmepumpen under en kortare period än vad som definieras av filtreringsklockan. På så sätt kan du ställa in fördröjd start och ett tidigt stopp eller helt enkelt förbjuda en drifttid (till exempel på natten).

Du har möjlighet att ställa in en starttimer (PÅ) och en stopptimer (AV).

Ställ in timern - Start (PÅ)

- Tryck på  i 2 sekunder, tills ikonen  blinkar.
- Tryck på , skärmen  blinkar (.
- Tryck på  för att ställa in timmarna med knapparna  och .
- Tryck på  för att ställa in minuterna med knapparna  och .
- Bekräfta genom att trycka på  sedan på  för att gå tillbaka till huvudskärmen.















Spara sker automatiskt efter 20s utan åtgärd.

Minuterna ställs in i steg om 10 minuter

Om indikeringen PÅ visas under tidsvisningen på huvudskärmen är detta en indikation på att starttimern (PÅ) är inställd.

4. ANVÄNDARGRÄNSSNITT (forts)

Ställ in timern - Stopp (AV)







- Tryck på  i 2 sekunder, tills ikonen  blinkar
- Tryck på , skärmen  blinkar (**ON**).
- Tryck på , skärmen  blinkar (**OFF**).
- Tryck på  för att ställa in timmarna med knapparna  och .
- Tryck på  för att ställa in minuterna med knapparna  och .
- Bekräfta genom att trycka på  sedan på  för att gå tillbaka till huvudskärmen.

Spara sker automatiskt efter 20s utan åtgärd.

Minuterna ställs in i steg om 10 minuter





Om indikeringen AV visas över tidsvisningen på huvudskärmen är detta en indikation på att stopptimern (AV) är inställd.

Konsultera timmers





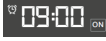

- Tryck på  i 2 sekunder, tills ikonen  blinkar.
- Tryck på , visning av starttid  blinkar.
- Tryck på , visning av stopptid  blinkar.
- Tryck på  för att gå tillbaka till huvudskärmen.

Ikonen  visas på huvudskärmen när timern för start och/eller en timer för stopp är inställd.

Radera timer för start (PÅ) och timer för stopp (AV)











- Tryck på  i 2 sekunder, tills ikonen  blinkar.
- Tryck 2 gånger på , starttiden blinkar .
- Tryck på  för att radera timern för start .

Efter att hat gjort steg 3, tryck på  för återgå till huvudskärmen eller gå till steg 4 för att fortsätta.

- Tryck på  för att komma åt tiden för stopp .
- Tryck på , tiderna för stopp blinkar .
- Tryck på  för att ta bort stopptimern .
- Tryck på  för att gå tillbaka till huvudskärmen.

4. ANVÄNDARGRÄNSSNITT (forts)

















Radera timern Stopp (AV)

- Tryck på  i 2 sekunder, tills ikonen  blinkar.
- Tryck 2 gånger på , tiderna för start blinkar .
- Tryck på  för att komma åt tiderna för stopp .
- Tryck på  tiderna för stopp blinkar .
- Tryck på  för att ta bort stopptimern .
- Tryck på  för att gå tillbaka till huvudskärmen.











4.5 Ställa in timerfunktionen i läge TYST

Läget TYST gör att värmepumpen kan användas i ekonomiskt och mycket tyst läge när värmebehovet är lågt (bibehålla bassängens temperatur eller vid behov av driften ultra.

Ställ in timern på läge TYST

- Tryck på  i 2 sekunder, tills ikonen  blinkar.
- Tryck på , ikonen  blinkar.
- Tryck på , skärmen  blinkar.
- Tryck på  för att ställa in tiden för start med hjälp av knapparna  och .
- Tryck på  sedan på  visningen  blinkar.
- Tryck på  för att ställa in tiden för stopp med hjälp av knapparna  och .
- Tryck på  för att bekräfta och sedan på  för att gå tillbaka till huvudskärmen.







Radera timern för läge TYST

- Tryck på  i 2 sekunder, tills ikonen  blinkar.
- Tryck på , ikonen  blinkar.
- Tryck på , visning av starttid  blinkar.
- Tryck på  endast timmarna blinkar.
- Tryck på , skärmen  blinkar.
- Tryck på  för att gå tillbaka till huvudskärmen.

Om timern PÅ raderas, raderas även timern AV automatiskt. Inställningssteget görs "timme för timme".

4. ANVÄNDARGRÄNSSNITT (forts)

Konsultera timern för läge TYST

- Tryck på  i 2 sekunder, tills ikonen  blinkar.
- Tryck på , ikonen  blinkar.
- Tryck på  för att visa tiden för start.
- Tryck på  för att visa tiden för stopp.
- Tryck på  för att gå tillbaka till huvudskärmen.



När ikonen  visas på huvudskärmen är antingen en timer för start eller en timer för stopp inställd i läge TYST.

4.6 Parkoppling av Bluetooth - Fjärrstyrning

Värmepumpen är utrustad med Bluetooth-funktion.

Tack vare applikationen "EyesPool Inverter Connect", kan du använda din smartphone som fjärrkontroll för att styra värmepumpen inom ett avstånd på 10 m i öppen terräng.

För att ta del av denna funktion  **Bluetooth**:

- ▶ Ladda ned applikationen "EyesPool Inverter Connect" gratis på  eller  .
- ▶ Skapa ett konto i applikationen.
- ▶ Följ videoinstruktionerna (länkar nedan) för att parkoppla din smartphone med värmepumpen:
<https://www.hayward.fr/article/tutoriels-hayward/s-line-pro-bluetooth-appairage>



4. ANVÄNDARGRÄNSSNITT (forts)

4.7 Val av driftläge

Värme - Automatisk - Kyla



Om värmepumpen har ställts in på läge Endast uppvärmning eller Endast kylning av installatören, är lägesändringen inte längre tillgänglig.

Tryck på knappen  för att ändra läget: Värme - Automatisk - Kyla.

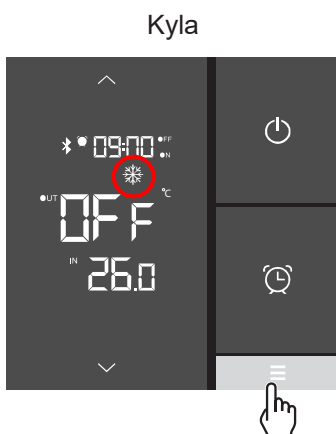
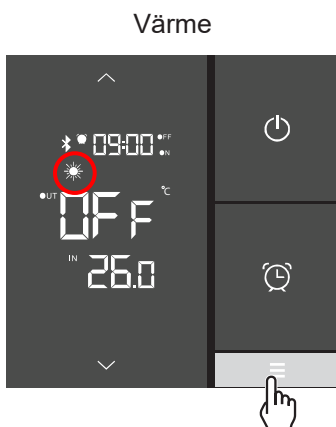





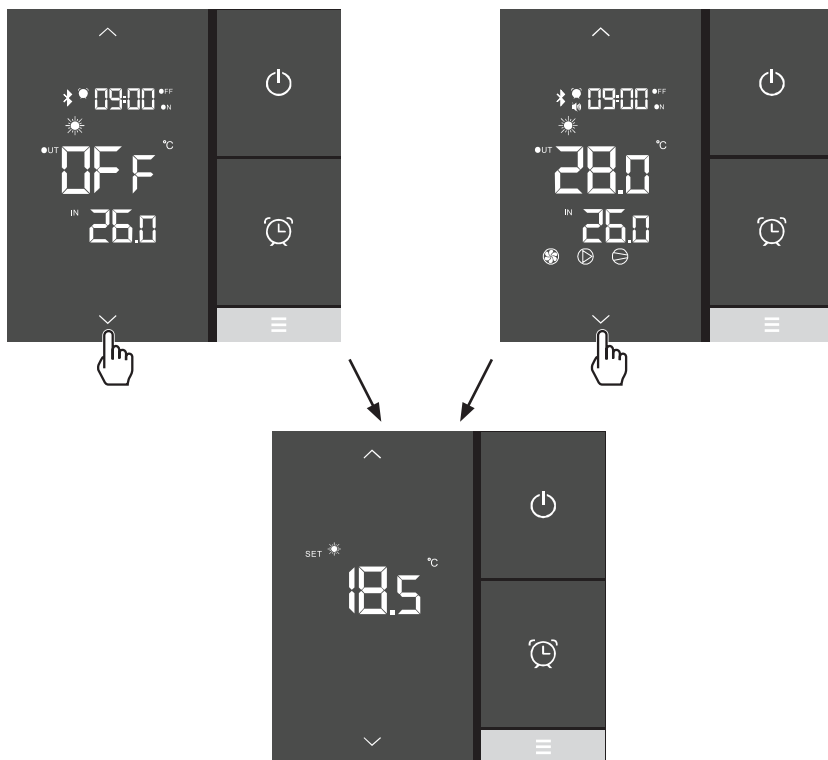

4. ANVÄNDARGRÄNSSNITT (forts)

4.8 Ställ in och visa börvärdet

Önskad vattentemperatur

Börvärdet justeras antingen i AV-läge eller i PÅ-läge med en noggrannhet på 0,5 °C.



- Tryck på  eller  för att få börvärdet att börja blinka.
- Tryck på  eller  för att definiera det önskade börvärdet.
- Tryck på  för att bekräfta eller på  för att annullera.

Inställningen sparas automatiskt efter 5 sekunder utan någon åtgärd.







Vi rekommenderar att aldrig överskrida en temperatur på 30 °C för att undvika förändringar i liners.

4. ANVÄNDARGRÄNSSNITT (forts)

4.9 Låsa och låsa upp pekskärmen

Du kan låsa och låsa upp skärmen i antingen i PÅ-läge eller i AV-läge.

- Tryck på  i 5 sekunder tills dessa att ikonen visas .
- För att låsa upp, tryck på  tills dess att ikonen försvinner .

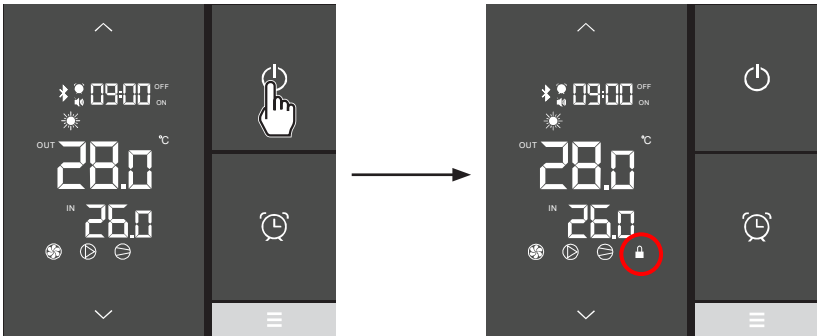

5. UNDERHÅLL OCH FÖRBEREDELSE INFÖR VINTERN

5.1 Underhåll

Dessa underhållsåtgärder måste utföras en gång per år för att säkerställa värmepumpens livslängd och dess felfria funktion.

- Rengör förångaren med hjälp av en mjuk borste eller en luft- eller vattenstråle (**använd aldrig en högtrycksspruta**).
- Kontrollera att condensatet flödar ordentligt.
- Kontrollera att de elektriska och hydrauliska ledningarna är åtdragna.
- Kontrollera att condensorn är hydrauliskt tät.
- Låt en **behörig yrkeskunnig person** kontrollera kylmediekretsen vid läckagedetektor.



Värmepumpen måste kopplas loss från varje elektrisk strömkälla före allt underhållsarbete. Underhållsarbetet får endast utföras av behörig personal som är kvalificerad för att hantera kylvätskor.

5.2 Förberedelser inför vintern

- Ställ värmepumpen i läget "OFF".
- Stäng av värmepumpens strömförsörjning.
- Töm condensorn med hjälp av tömningsventilen för att undvika varje risk för skada (stor risk för frost).
- Stäng "överströmningventilen" och skruva loss skarvanslutningarna till inloppet/utloppet.
- Avlägsna det stillastående vattnet i condensorn så mycket som möjligt med hjälp av en tryckluftspistol.
- Täpp till värmepumpens vatteninlopp och -utlopp för att undvika att främmande föremål kommer in.
- Täck värmepumpen med en vinterpresenning avsedd för detta.



Varje skada som orsakats av dåliga vinterförberedelser medför att garantin blir ogiltig.

6. BILAGOR

6.1 Kopplingscheman

HP5081DT3LVM / HP5111DT3LV

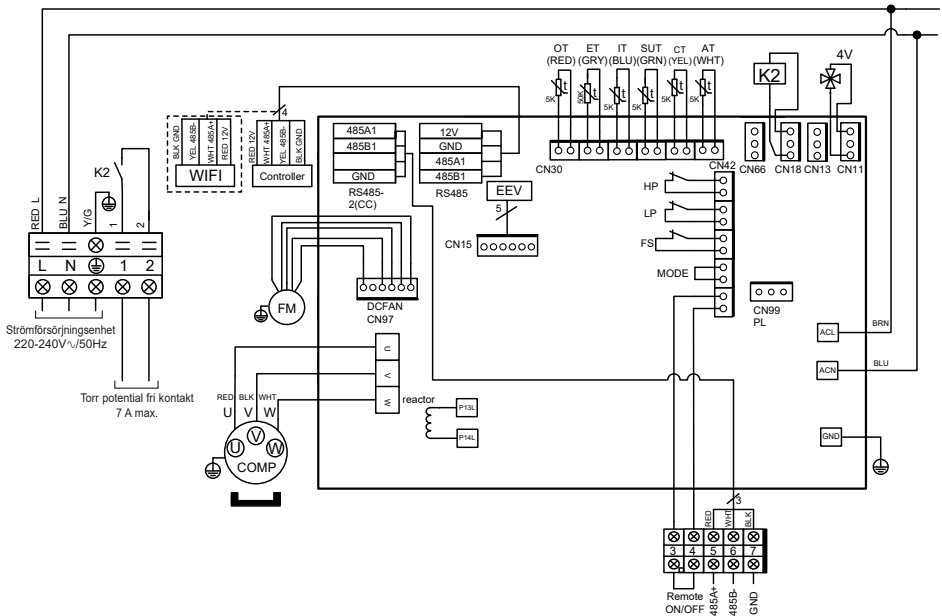

TECKENFÖRKLARING

- | | |
|---|--|
| AT: LUFTEMPERATURSOND | LP: PRESSOSTAT LÅGT TRYCK |
| COMP: KOMPRESSOR | OT: TEMPERATURSOND VATTENUTLOPP |
| CT: TEMPERATURSOND FÖRÅNGARE | SUT: TEMPERATURSOND INSUGNING |
| EEV: ELEKTRONISK TRYCKREGULATOR | 4V: FYRVÄGSVENTIL |
| FM: FLÅKTMOTOR | K2: TORR KONTAKT MAX 16A |
| FS: DETEKTOR FÖR VATTENFÖREKOMST | ET: TEMPERATURSOND UTLOPP |
| HP: PRESSOSTAT HÖGT TRYCK | --- : ALTERNATIV |
| IT: TEMPERATURSOND VATTENINLOPP | |

6. BILAGOR (fortsättning)

6.2 Anslutningar för prioritetsuppvärmning av enfaspump

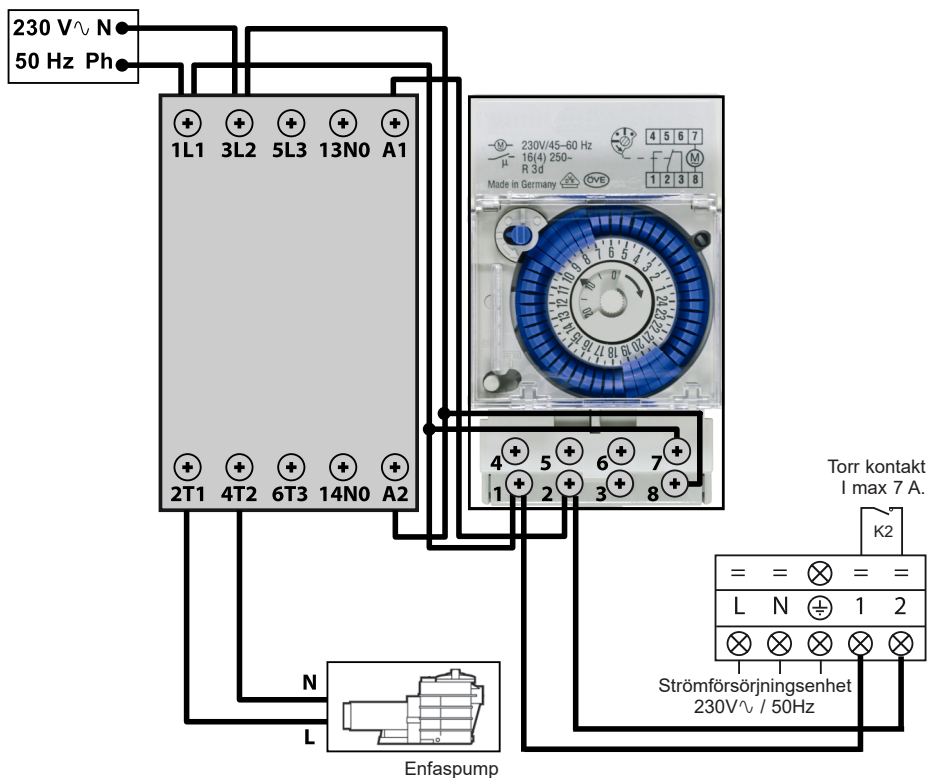

Plintarna 1 och 2 ger en torr potential fri kontakt utan polaritet på 230V \sim / 50Hz. Anslut plintarna 1 och 2 i enlighet med ovanstående kopplingsschema för att styra filterpumpens drift under en 2 minuters cykel, varje timme om bassängtemperaturen ligger under börvärdet.



Anslut aldrig strömmen av filtreringspumpen direkt till plint 1 och 2.

6. BILAGOR (fortsättning)

6.3 Sprängvyer och reservdelar/addendum

HP5081DT3LV / HP5111DT3LV / HP5151DT3LV

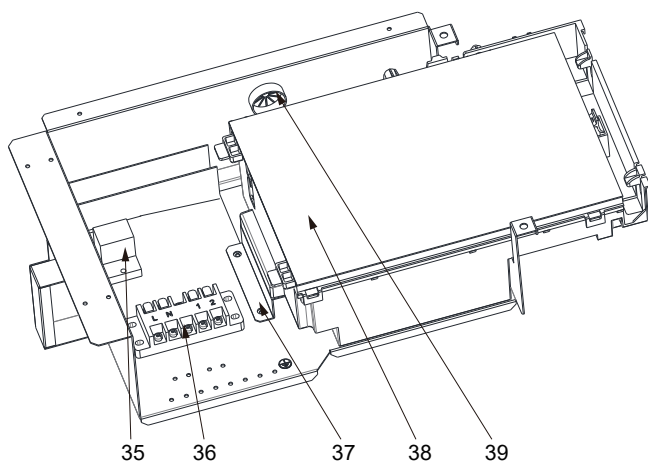
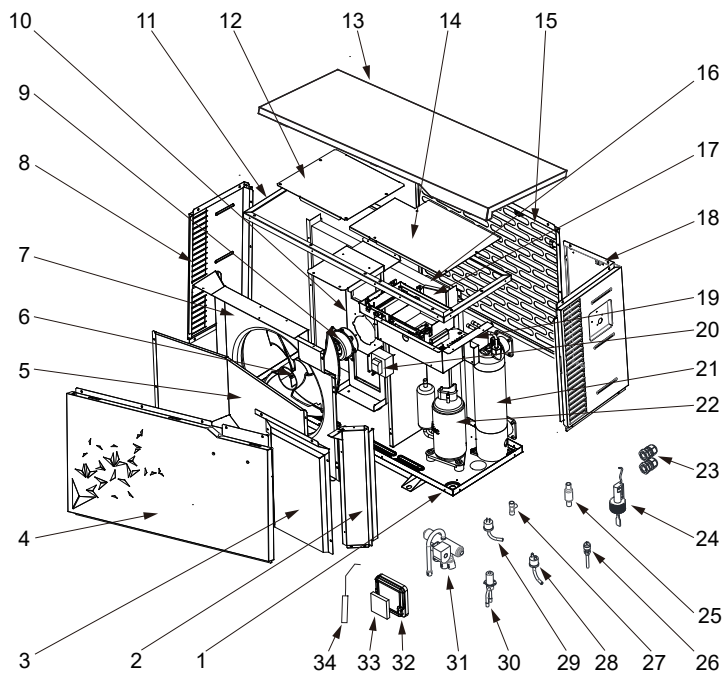

6. BILAGOR (fortsättning)

Hänv.	Beteckning	Ref.	HP5081DT3LV	HP5111DT3LV	HP5151DT3LV
1	/	/	/	/	/
2	/	/	/	/	/
3	/	/	/	/	/
4	Främre panel	HWX80715842	✓	✓	ej tillämpligt
		HWX80715857	ej tillämpligt	ej tillämpligt	✓
5	/	/	/	/	/
6	Fläktpropell	HWX301030000006	✓	✓	ej tillämpligt
		HWX20000270004	ej tillämpligt	ej tillämpligt	✓
7	/	/	/	/	/
8	Panel vänster	HWX80713420	✓	✓	ej tillämpligt
		HWX80713423	ej tillämpligt	ej tillämpligt	✓
9	Fläktmotor DC	HWX80200018	✓	✓	ej tillämpligt
		HWX20000330132	ej tillämpligt	ej tillämpligt	✓
10	Motorstöd	HWX80708597	✓	✓	ej tillämpligt
		HWX80709977	ej tillämpligt	ej tillämpligt	✓
11	/	/	/	/	/
12	/	/	/	/	/
13	Övre panel	HWX80708601	✓	✓	ej tillämpligt
		HWX80709984	ej tillämpligt	ej tillämpligt	✓
14	/	/	/	/	/
15	Bakpanel	HWX80710829	✓	✓	ej tillämpligt
		HWX80710966	ej tillämpligt	ej tillämpligt	✓
16	Vingförsedd förångare	HWX80600849	✓	ej tillämpligt	ej tillämpligt
		HWX80600781	ej tillämpligt	✓	ej tillämpligt
		HWX80600835	ej tillämpligt	ej tillämpligt	✓
17	/	/	/	/	/
18	Panel höger	HWX80713421	✓	✓	ej tillämpligt
		HWX80713424	ej tillämpligt	ej tillämpligt	✓
19	/	/	/	/	/
20	Reaktans	HWX82500020	✓	✓	ej tillämpligt
		HWX82500021	ej tillämpligt	ej tillämpligt	✓
21	Kondensator av titan PVC	HWX80600939	✓	ej tillämpligt	ej tillämpligt
		HWX80600940	ej tillämpligt	✓	✓
		HWX80600096	ej tillämpligt	ej tillämpligt	✓
22	Kompressor	HWX20000110448	✓	✓	ej tillämpligt
		HWX80100046	ej tillämpligt	ej tillämpligt	✓
23	Ringtätning	HWX20012249	✓	✓	ej tillämpligt
		HWX20012238	ej tillämpligt	ej tillämpligt	✓
24	Vattenflödesdetektor	HWX83000068	✓	✓	✓
25	Filter Ø9.7-Ø9.7 (Ø19) Filter Ø9.7-Ø9.7 (Ø28)	HWX20000140178	✓	✓	ej tillämpligt
		HWX20041444	ej tillämpligt	ej tillämpligt	✓
26	Tryckkuttag 40mm-1/2"	HWX20000140150	✓	✓	✓
27	Kontakt T Ø9.52-2 xØ6.35(T) x 1.0 Kontakt T Ø6.5-2 x Ø6.5(T) x 0.75	HWX30403000002	✓	✓	ej tillämpligt
		HWX20001460	ej tillämpligt	ej tillämpligt	✓
28	Pressostat lågt tryck NO 0.30MPa/0.15MPa	HWX20000360157	✓	✓	✓
29	Pressostat högt tryck NC 3.2MPa/4.4MPa	HWX20013605	✓	✓	✓
30	Elektronisk expansionsventil	HWX81000011	✓	✓	ej tillämpligt
		HWX81000017	ej tillämpligt	ej tillämpligt	✓
		HWX20041437	✓	✓	ej tillämpligt
31	Fyrvägsventil	HWX20000140485	ej tillämpligt	ej tillämpligt	✓
		HWX80901004	✓	✓	✓
32	Kontrollstöd	HWX80901004	✓	✓	✓
33	LCD-kontroll Bluetooth	HWX72200312	✓	✓	✓

6. BILAGOR (fortsättning)

HP5081DT3LV / HP5111DT3LV / HP5151DT3LV

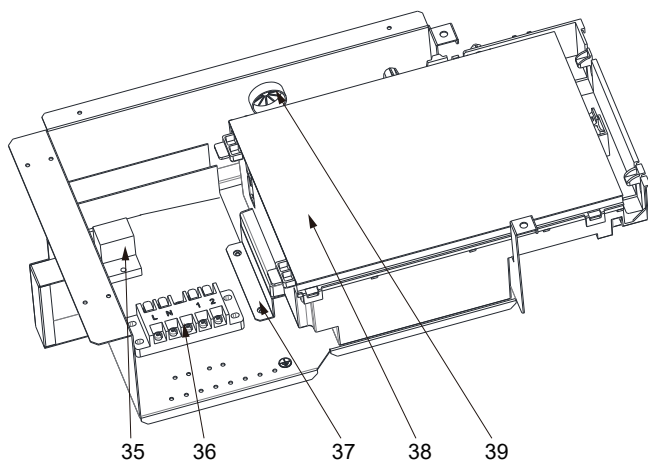
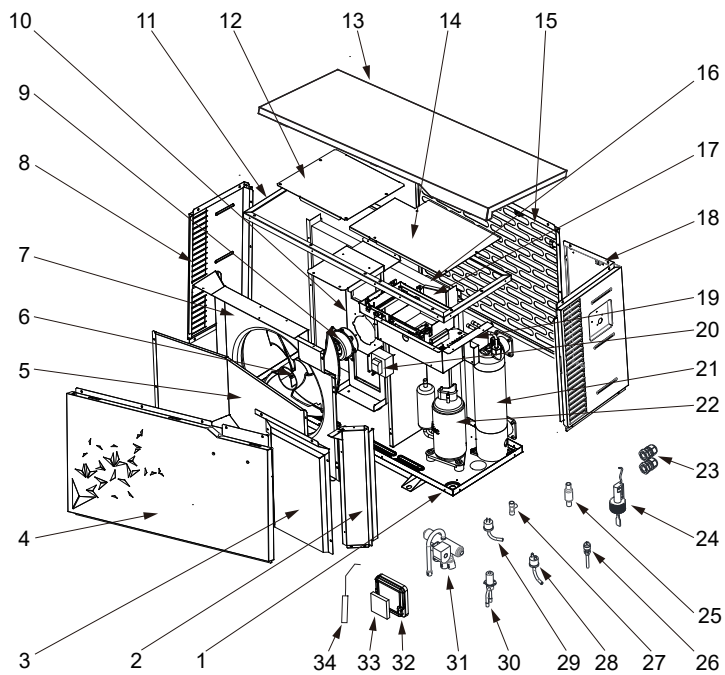

6. BILAGOR (fortsättning)

Hänv.	Beteckning	Ref.	HP5081DT3LV	HP5111DT3LV	HP5151DT3LV
34	Sond till vattenutlopp 5k-410mm	HWX83000050	✓	✓	✓
	Sond till vatteninlopp 5k-850mm	HWX83000052	✓	✓	✓
	Utloppssond till kompressor 50k-660mm	HWX83000026	✓	✓	✓
	Sugsond till kompressor 5k-560mm	HWX83000044	✓	✓	ej tillämpligt
	Sugsond till kompressor 5k-760mm	HWX83000053	ej tillämpligt	ej tillämpligt	✓
	Avfrostningssond 5k-680mm	HWX83000051	✓	✓	ej tillämpligt
	Avfrostningssond 5k-1040mm	HWX83000045	ej tillämpligt	ej tillämpligt	✓
Temperatursond Air 5k-350 mm	HWX83000049	✓	✓	✓	
35	Relä K2	HWX20000360297	✓	✓	✓
36	Anslutningsplint L-N-GND -5 anslutningar 4mm ²	HWX40003901	✓	✓	✓
37	/	/	/	/	/
38	Elektroniskt kort Driver	HWX72200168SL08	✓	ej tillämpligt	ej tillämpligt
		HWX72200168SL11	ej tillämpligt	✓	ej tillämpligt
		HWX72200168SL15	ej tillämpligt	ej tillämpligt	✓
39	/	/	/	/	/

6. BILAGOR (fortsättning)

6.4 Reparationshandbok



Vissa åtgärder måste vidtas av en auktoriserad tekniker.

Vid fel visas följande indikationer på skärmen:

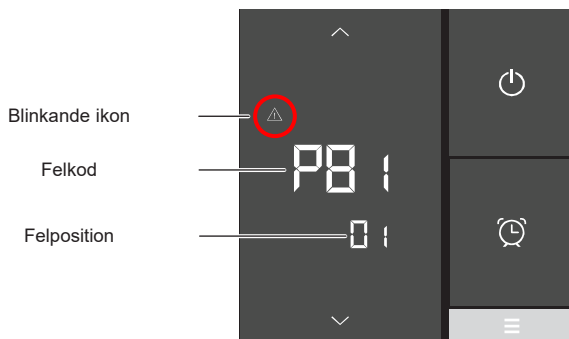

Vid fel, tryck på  eller  för att bläddra genom felkoderna. Se tabellen nedan.



Efter att ha löst problemet kvitteras felet automatiskt, triangeln försvinner.

6. BILAGOR (fortsättning)

Fel	Felkoder	Beskrivning	Lösning
Fel på sensorn till vatteninloppet (IT)	PD1	Sensorn är öppen eller kortsluten	Kontrollera anslutningarna på förlängningskontakten eller byt ut sensorn
Fel på sensorn till vattenutloppet (OT)	PD2		
Fel på utetemperatursensor (AT)	PD4		
Fel på avfrostningssenor (CT)	PD5		
Fel på kompressorns sugsensor (SUT)	PD7		
Fel på kompressorns utloppssensor (ET)	PD81		
Fel på högtryck	ED1	Sensorn är öppen eller kortsluten	Kontrollera anslutningarna på förlängningskontakten eller byt ut sensorn
			Kontrollera vattenflödet
			Kontrollera detektorn till vattenflödet
			Kontrollera ventilernas öppning
			Kontrollera förbikopplingen
			Kontrollera om förångaren är smutsig
			Vattentemperaturen är för varm
			Kondensproblem efter underhåll, töm och evakuera kylkretsen
För hög vätskepåfyllning, avlägsna vätska från en behållare			
Fel lågt tryck	ED2	Sensorn är öppen eller kortsluten	Kontrollera anslutningarna på förlängningskontakten eller byt ut sensorn
			Betydande köldmedieläckage, kontrollera detektorn för läckage
			Luffflödet är för lågt, kontrollera fläktens rotationshastighet
			Kontrollera om förångaren är smutsig, rengör ytan

6. BILAGOR (fortsättning)

Fel	Felkoder	Beskrivning	Lösning
Fel på flödesdetektorn	E03	Sensorn är öppen eller kortsluten	Kontrollera anslutningarna CN29/OVT på kortet eller byt ut sensorn
			Brist på vatten, kontrollera filteringspumpens funktion
			Kontrollera avstängningsventilernas öppningen
			Kontrollera förbikopplingens inställning
Temperaturskillnad inlopp/utlopp > 13 °C	E05	Gäller endast i låge kyla	Brist på vatten, kontrollera filteringspumpens funktion
			Kontrollera avstängningsventilernas öppningen
			Kontrollera förbikopplingens inställning
Frostskydd	E07	Vattnets utloppstemperatur < 4 °C	Stoppa värmepumpen, töm kondensorn risk för frysning
Kommunikationsproblem	E08	Ingen kommunikation mellan det elektroniska kortet och användargränssnittet	Kontrollera anslutningarna och kontaktarna - se elschema
Frostskydd nivå 1	E19	2°C < vattentemperatur < 4 °C och lufttemperatur < 0 °C	Stoppa driften av värmepumpen, töm kondensorn för att undvika frysning, som standard startar värmepumpen filteringspumpen för att förhindra isbildning
Frostskydd nivå 2	E29	Vattentemperatur < 2 °C och lufttemperatur < 0 °C	Stoppa driften av värmepumpen, töm kondensorn för att undvika frysning, som standard startar värmepumpen filteringspumpen och värmepumpen för att förhindra isbildning.
Fel på fläktmotor	F03 I	Motor blockerad eller anslutning felaktig	Kontrollera att rotationen är fri; kontrollera CN97/DCFAN, byt ut motorn
Fel på fläktmotor	F05 I	Fel på anslutning	Kontrollera DCFAN/CN97, byt ut motorn
Utetemperaturen är för låg	LP	Driftgräns nådd	Stoppa värmepumpen
Värmepumpen startar inte	- - RL	Kontakt (5-6) På distans På/Av öppen	Stäng kontakten (5-6) På distans På/Av (se elschema)

6. BILAGOR (fortsättning)

6.5 Garanti

GARANTIVILLKOR

Alla HAYWARD-produkter omfattas av en garanti mot tillverknings- eller materialfel under en tvåårsperiod räknat från inköpsdatumet. Alla garantikrav måste åtföljas av ett inköpsbevis som bestyrker detta datum. Vi rekommenderar därför att du sparar din faktura.

HAYWARDS garanti är begränsad till reparation eller ersättning, enligt HAYWARDS val, av defekta produkter i den mån som de har använts på normalt sätt, i enlighet med instruktionerna som nämns i bruksanvisningen, samt att produkten inte har ändrats på något sätt och endast använts med HAYWARDS komponenter och delar. Skador som orsakats av frost och kemikalieangrepp täcks inte av garantin.

Alla andra avgifter (transport, arbete ...) är undantagna från garantin.

HAYWARD kommer inte att kunna hållas ansvarigt för någon direkt eller indirekt skada som förorsakats av felaktig installering, anslutning eller drift av produkten.

Ta kontakt med din återförsäljare för att ställa garantikrav och begära reparation eller ersättning av en produkt. Inget återlämnande av material till vår fabrik kommer att godtas utan vårt föregående skriftliga medgivande.

Slitagedelar omfattas inte av garantin.

Denna sida är avsiktligt lämnad tom



S.Line Pro *Fi*

ТЕПЛОВОЙ НАСОС ДЛЯ ПЛАВАТЕЛЬНОГО БАССЕЙНА



Руководство по монтажу и эксплуатации

СОДЕРЖАНИЕ

1. ПРЕДИСЛОВИЕ	1
2. ТЕХНИЧЕСКИЕ ХАРАКТЕРИСТИКИ	4
2.1 Технические данные теплового насоса	4
2.2 Рабочий диапазон	5
2.3 Размеры	6
3. УСТАНОВКА И ПОДКЛЮЧЕНИЕ	7
3.1 Принципиальная Схема	7
3.2 Тепловой насос	7
3.3 Гидротехническое подключение	8
3.4 Электрическое Подключение	9
3.5 Первый запуск	10
4. ИНТЕРФЕЙС ПОЛЬЗОВАТЕЛЯ	12
4.1 Общие сведения	12
4.2 Регулировка расхода воды	14
4.3 Установка времени	15
4.4 Установка таймеров включения и выключения	15
4.5 Настройка функции «Таймер режима ТИШИНЫ»	17
4.6 Подключение Bluetooth — дистанционное управление	18
4.7 Выбор режима работы	19
4.8 Установка и визуализация заданного значения	20
4.9 Блокировка и разблокировка сенсорного экрана	21
5. ТЕХНИЧЕСКОЕ ОБСЛУЖИВАНИЕ И КОНСЕРВАЦИЯ НА ЗИМУ	22
5.1 Техническое обслуживание	22
5.2 Консервация на зиму	22
6. ПРИЛОЖЕНИЯ	23
6.1 Электрические схемы	23
6.2 Включение подогрева в качестве приоритета	25
6.3 Вид в разборе и съемные элементы	26
6.4 Гид по устранению неисправностей	30
6.5 Гарантия	33

Внимательно прочитать и сохранить для дальнейших консультаций.

Этот документ необходимо передать владельцу плавательного бассейна, чтобы он его сохранил в надежном месте.

1. ПРЕДИСЛОВИЕ

Благодарим вас за покупку теплового насоса для бассейна Hayward. Тепловой насос S.LINE PRO был разработан согласно строгим производственным стандартам, чтобы соответствовать высочайшему уровню требуемого качества.

Тепловые насосы S.LINE PRO обеспечат невероятную производительность на протяжении всего купального сезона, регулируя мощность, энергопотребление и уровень шума, необходимые для подогрева бассейна, с помощью логической схемы контроля FULL INVERTER.



Перед использованием устройства внимательно прочитайте инструкции, приведенные в этом руководстве.

Тепловые насосы S.LINE PRO предназначены исключительно для нагрева воды в бассейне. Не используйте это оборудование для других целей.

Это руководство включает в себя всю необходимую информацию, касающуюся установки, устранения неполадок и технического обслуживания.

Внимательно прочитайте это руководство, прежде чем открывать устройство или выполнять техническое обслуживание. Производитель данного продукта не будет нести ответственность в случае получения пользователем травмы или повреждения устройства из-за возможных ошибок во время установки, устранения неисправностей или неправильного технического обслуживания. Крайне важно всегда следовать инструкциям этого руководства.

Любое невыполнение рекомендаций аннулирует гарантию.

1. ПРЕДИСЛОВИЕ (продолжение)



Правила техники безопасности



Это устройство содержит R32.

Используйте исключительно хладагент R32. Любое другое газообразное вещество, смешанное с R32, может спровоцировать чрезмерное давление, которое может привести к поломке или разрыву труб и травмированию людей.

Во время ремонта или технического обслуживания используйте медные трубы, соответствующие стандарту EN 12375-1 (май 2020 г.) и Европейской директиве 97/23 / ЕС по оборудованию, работающему под давлением.

Когда тепловой насос находится под давлением, не проделывайте отверстия в трубах и не пытайтесь их паять. Существует опасность взрыва.

Не подвергайте устройство воздействию огня, искр или других источников возгорания. Оно может взорваться, что, возможно, приведет к серьезным травмам или смерти.



Тепловой насос предназначен исключительно для установки на улице.

- Тепловой насос должен храниться в хорошо проветриваемом помещении с площадью пола более $A_{\text{мин}}$ (м^2), определяемой по следующей формуле:
$$A_{\text{мин}} = (M / (2,5 \times 0,22759 \times h_0))^2,$$
где M — количество хладагента в устройстве в кг, а h_0 — высота хранения. Для напольного хранения $h_0 = 0,6$ м.
- Устанавливать устройство должен квалифицированный персонал.
- Не устанавливайте тепловой насос на подставку, которая может усилить вибрацию устройства.
- Убедитесь в том, что размер подставки для устройства соответствует его весу.
- Не устанавливайте тепловой насос в месте, которое может повышать уровень шума, или где шум от устройства может помешать соседям.

1. ПРЕДИСЛОВИЕ (продолжение)

- Любые электрические соединения должны выполняться квалифицированным электриком-профессионалом и в соответствии с действующими в стране установки стандартами, см. § 3.4.
- Отключите основное электропитание и рубильник перед выполнением любых электрических работ. Невыполнение инструкций может привести к поражению электрическим током.
- Перед установкой убедитесь в том, что заземляющий кабель не обрезан и не отсоединен.
- Подсоедините и правильно пережмите кабель питания. В случае плохого соединения электрические элементы могут повредиться.
- Воздействие воды или влажной среды на тепловой насос может привести к поражению электрическим током. Будьте очень осторожны.
- Если вы обнаружите какую-либо неисправность или аномальную ситуацию, не устанавливайте тепловой насос и немедленно свяжитесь с вашим дилером.
- Техническое обслуживание и различные операции должны выполняться с частотой и во время, рекомендуемые в этом руководстве.
- Ремонт должен выполняться квалифицированным персоналом.
- Используйте только оригинальные запчасти.
- Применяйте только рекомендованный в этом руководстве метод очистки.

Важная информация об используемом хладагенте

Этот продукт содержит фторированные парниковые газы, контролируемые Киотским протоколом. Не выпускайте эти газы в атмосферу.

Тип хладагента: R32

Значение ПГП(1) — 675, значение основано на 4-м отчете МГЭИК.

Количество хладагента в соответствии с регламентом F-Gas 517/2014 указано на заводской табличке устройства.

В соответствии с европейским или местным законодательством могут потребоваться периодические проверки утечки хладагента. Для получения дополнительной информации свяжитесь с вашим местным поставщиком.

(1) Потенциал глобального потепления.

2. ТЕХНИЧЕСКИЕ ХАРАКТЕРИСТИКИ

2.1 Технические данные теплового насоса

Модели	S.LINE PRO	HP5081DT3LV	HP5111DT3LV	HP5151DT3LV
Напряжение питания	B	220–240 В ~/1 ph/50 Гц		
Хладагент	/	R32		
Количество	кг	0,45	0,50	0,65
Масса в tCO ₂ eq	/	0,30	0,34	0,44
Частота проверок на наличие утечек	/	Требования отсутствуют, но рекомендуется ежегодно		
Нагревательная способность мин. – макс. ^(а)	кВт	2,83 – 8,16	1,95 – 10,90	5,27 – 15,66
Поглощаемая электрическая мощность мин. – макс. ^(а)	кВт	0,212 – 1,19	0,150 – 1,92	0,457 – 2,80
Номинальный эксплуатационный ток мин. – макс. ^(а)	A	1,41 – 5,20	1,05 – 8,49	2,04 – 12,28
КПД мин. – макс. ^(а)	/	13,30 – 6,81	12,92 – 5,67	11,53 – 5,59
Нагревательная способность мин. – макс. ^(б)	кВт	1,77 – 5,91	1,86 – 8,40	3,81 – 11,67
Поглощаемая электрическая мощность мин. – макс. ^(б)	кВт	0,31 – 1,28	0,30 – 1,83	0,588 – 2,71
КПД мин. – макс. ^(б)	/	5,70 – 4,62	6,20 – 4,59	6,48 – 4,31
Максимальный эксплуатационный ток (МЭТ)	A	6,50	10,30	14
Номинал плавкого предохранителя	gG	10	12	16
Изогнутый предохранитель C	C	10	12	16
Пусковой ток	A	< МЭТ		
Гидравлическое соединение	мм	50 мм		
Номинальный расход воды ^(а)	м ³ /ч	3,50	4,60	6,70
Максимальная потеря напора воды	кПа	8	5	10
Компрессор	/	DC Inverter MITSUBISHI ELECTRIC		DC Inverter Mitsubishi
Тип	/	Двойной ротационный		Двойной ротационный
Количество	/	1		
Сопrotивление обмотки при температуре 20 °C	Ом	1,91 +/- 5%		0,95 +/- 5%
Вентилятор	/	осевой		
Количество	/	1		
Диаметр	мм	405		500
Количество лопастей	/	3		
Двигатель	/	DC Inverter		
Количество	/	1		
Скорость вращения	об/мин	500 – 800	500 – 900	500 – 750
Скорость в бесшумном режиме	об/мин	500	500	500
Уровень акустического давления на 1 м	дБ(А)	45,1	48,6	54,1
Уровень акустического давления на 10 м	дБ(А)	27,9	31,6	36,9
Чистые размеры устройства (Д-Ш-В)	мм	1011 / 430 / 622		1025 / 480 / 768
Масса	кг	61	61	87

(а) Сухой воздух 27 °C — относительная влажность 78 % — температура воды на входе 26 °C.



(б) Сухой воздух 15 °C — относительная влажность 71 % — температура воды на входе 26 °C.

2. ТЕХНИЧЕСКИЕ ХАРАКТЕРИСТИКИ

(продолжение)

2.2 Рабочий диапазон

Для обеспечения надежной и эффективной работы теплового насоса используйте его в следующих рабочих диапазонах температур и влажности.

	Режим подогрева 	Режим Охлаждение 
Температура окружающей среды	-7°C – +35°C	+7°C – +43°C
Температура воды	+12°C – +32°C	+8°C – +40°C
Относительная влажность	< 80%	< 80%
Рабочий диапазон заданного значения	+15°C – +32°C	+8°C – +32°C



Если температура или влажность не соответствуют указанным условиям, может сработать защитное устройство, и тогда тепловой насос может отключиться.



Максимальная температура нагрева ограничена до 32°C во избежание повреждения покрытия. Фирма Nauward не несет ответственности в случае эксплуатации при температуре выше 32°C.

2. ТЕХНИЧЕСКИЕ ХАРАКТЕРИСТИКИ (продолжение)

2.3 Размеры

Модели :

HP5081DT3LV / HP5111DT3LV / HP5151DT3LV

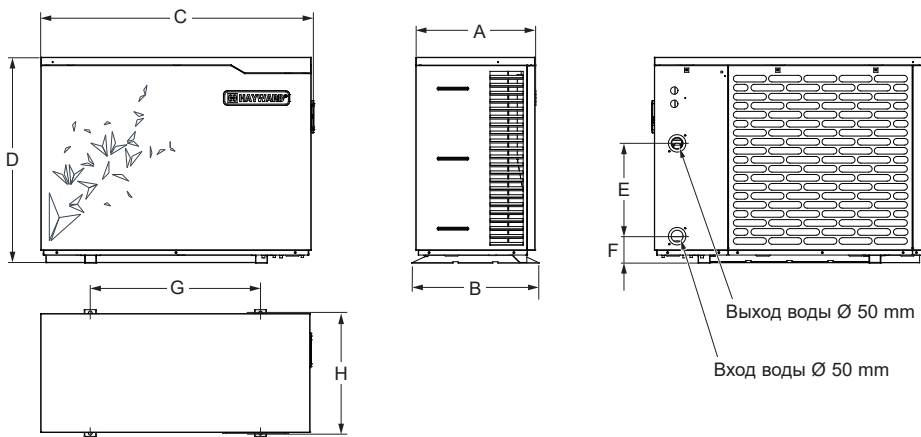

Устройство : мм

Позиция \ Модель	HP5081DT3LV / HP5111DT3LV	HP5151DT3LV
A	393	453
B	430	480
C	1011	1030
D	621,5	776
E	350	350
F	97,5	102
G	625	645
H	406	456

3. УСТАНОВКА И ПОДКЛЮЧЕНИЕ

3.1 Принципиальная Схема

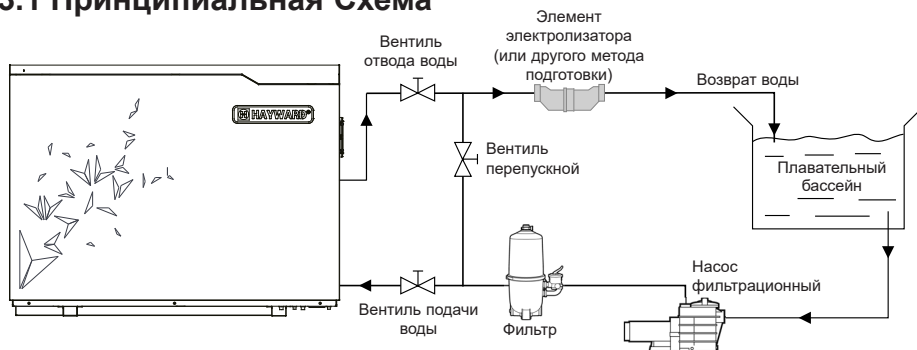

Примечание : Тепловой насос поставляется без какого-либо дополнительного оборудования для подготовки или фильтрации воды. Представленные на схеме элементы поставляются фирмой, осуществляющей установку.

3.2 Тепловой насос



Разместите тепловой насос на открытом воздухе, отдельно от любого другого закрытого оборудования.

Разместите его под навесом, с соблюдением всех указанных минимальных расстояний до других предметов, чтобы избежать всех рисков, связанных с рециркуляцией воздуха и возможного отрицательного влияния теплового насоса на состояние окружающей среды.

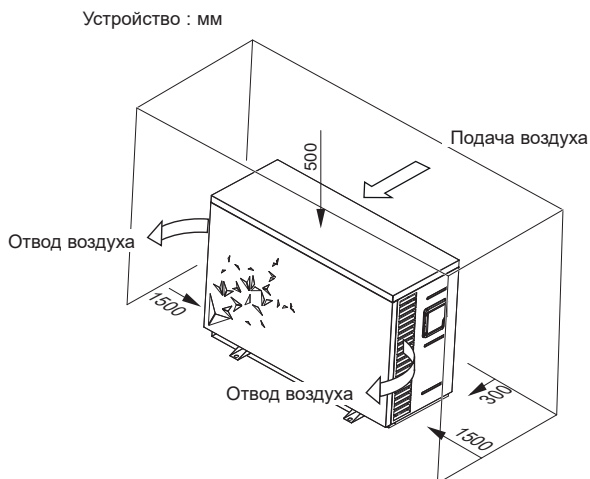

3. УСТАНОВКА И ПОДКЛЮЧЕНИЕ (продолжение)



Желательно установить тепловой насос на отдельной бетонной площадке или в другом предусмотренном для этого месте, с использованием входящих в комплект поставки сайлентблоков (болты и шайбы в комплект поставки не входят).

Максимальное расстояние между тепловым насосом и плавательным бассейном не должно превышать 15 м. Общая длина шлангов подачи и отвода воды не должна превышать 30 м.

Изолировать шланги от поверхности земли и не закапывать.

Тепловой насос должен быть установлен на минимальном расстоянии от бассейна в соответствии с NF C 15-100 (либо в 3,5 м от водной поверхности во Франции) или в соответствии со стандартами установки в других странах.

Не устанавливать тепловой насос вблизи источников тепла.

При установке в снежных регионах, рекомендуется устанавливать изделие в помещении, чтобы избежать накопления снега на испарителе.

3.3 Гидротехническое подключение

Тепловой насос поставляется с двумя штуцерными соединениями диаметром 50 мм с накидной гайкой. Для подвода воды используйте ПВХ шланги Ø 50 мм. Соедините входное отверстие для воды теплового насоса со шлангом, ведущим к фильтрационному блоку, затем соедините выходное отверстие для воды теплового насоса со шлангом, подающим воду в бассейн (см. приведенную ниже схему).

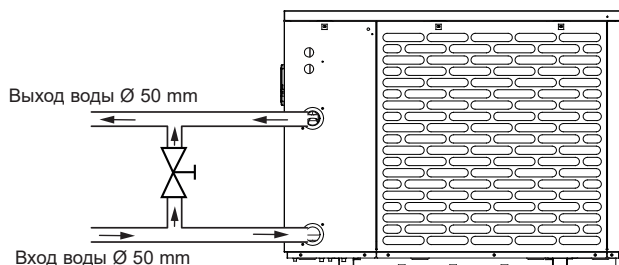

Установите так называемый "перепускной" вентиль между входным и выходным отверстиями теплового насоса.



Если используются автоматическое питательное устройство или электрлизатор, они должны быть установлены непосредственно после теплового насоса с целью предохранения конденсатора Titape от чрезмерного накопления в нем химических продуктов.



Постарайтесь установить перепускной вентиль и поставляемые штуцерные соединения на одном уровне с входом и выходом воды на устройстве, чтобы упростить спуск воды на зимний период, облегчив таким образом доступ к элементам и демонтаж на период технического обслуживания.

3. УСТАНОВКА И ПОДКЛЮЧЕНИЕ (продолжение)

3.4 Электрическое Подключение



Электроподключение и все соединения данного оборудования должны соответствовать местным действующим правилам установки.

Франция	NF C15-100	Великобритания	BS7671:1992
Дания	DIN VDE 0100-702	Англия и Уэльс	EVHS-HD 384-7-702
А	ÖVE 8001-4-702	Венгрия	MSZ 2364-702/1994/MSZ 10-553 1/1990
Испания	UNE 20460-7-702 1993, RECBT ITC-BT-31 2002	Мэн	MSA HD 384-7-702.S2
Ирландия	Монтажные правила + IS HD 384-7-702	Польша	PN-IEC 60364-7-702:1999
Италия	CEI 64-8/7	Чехия	CSN 33 2000 7-702
Люксембург	384-7.702 S2	Словакия	STN 33 2000-7-702
Нидерланды	NEN 1010-7-702	Словения	SIST HD 384-7-702.S2
Португалия	RSIUÉE	Турция	TS IEC 60364-7-702



Убедитесь, что имеющееся в наличии электропитание и частота соответствуют требуемым параметрам тока, приняв во внимание специфическую установку прибора и потребности всех других устройств, подключенных к данной цепи.

**HP5081DT3LV / HP5111DT3LV / HP5151DT3LV
230V ~ +/- 10 % 50 Hz 1 Фаза**

Соблюдайте требования соответствующей схемы соединений в приложении.

Три контактных соединения предназначены для подключения электропитания, два других - для подключения механизма управления фильтрационного насоса (Системы автоматического управления).

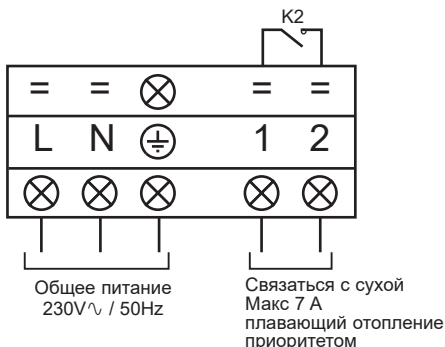

3. УСТАНОВКА И ПОДКЛЮЧЕНИЕ (продолжение)



Цепь электропитания должна быть снабжена соответствующим защитным устройством (предохранителем для защиты электродвигателей и кабелей типа gG) или автоматическим выключателем (кривая C), а также дифференциальным автоматом на 30 мА (см. следующую таблицу).

Модели		HP5081DT3LV	HP5111DT3LV	HP5151DT3LV
Электропитание	V/Ph/ Hz	230V~ 50Hz	230V~ 50Hz	230V~ 50Hz
Предел срабатывания предохранителя	A	10 gG	12 gG	16 gG
Автоматический выключатель, кривая C	A	10 C	12 C	16 C
Сечение кабеля	mm ²	3G 2,5	3G 2,5	3G 2,5



Используйте кабель питания типа RO 2V / R 2V или аналогичный.



Сечения кабеля даны из расчета максимальной длины - 25 м. Тем не менее, необходимо их проверять и адаптировать согласно условиям установки.



Перед открытием блока электроуправления всегда отключайте источник основного питания.

3.5 Первый запуск

Процедура запуска - после того, как закончена установка, неуклонно следуйте следующему порядку действий :

- 1) Проверните вентиляторы рукой для проверки их свободного вращения и соответствия крепления винта на валу мотора.
- 2) Убедитесь в том, что устройство правильно подключено к источнику основного питания (см. схему соединения в приложении).
- 3) Включите фильтрационный насос.
- 4) Перед тем как перейти к режимам подогрева или охлаждения, проверьте, чтобы все вентили были открыты и чтобы вода поступала в устройство.
- 5) Проверьте, чтобы трубка оттока конденсата была правильно установлена, чтобы не создавалось никаких помех.
- 6) Включите электропитание устройства, затем нажмите кнопку Пуск/Стоп  на панели управления.

3. УСТАНОВКА И ПОДКЛЮЧЕНИЕ (продолжение)

- 7) Убедитесь в том, что символы тревоги или блокировки не отображаются. При необходимости см. руководство по устранению неисправностей (см. § 6.4).
- 8) Установите пропускную способность для воды с помощью перепускного вентиля (см. § 2.1 и 4.2) на уровне, предусмотренном для соответствующей модели, так, чтобы разница температур воды на входе/выходе составляла 2°C.
- 9) После нескольких минут работы проверьте, чтобы температура воздуха, выходящего из устройства, понизилась (была между 5 и 10°).
- 10) Не выключая устройства, остановите фильтрационный насос. Устройство должно автоматически отключиться и показать код ошибки E03.
- 11) Оставьте устройство и насос плавательного бассейна включенными круглосуточно, пока температура воды не достигнет желаемого уровня. Когда температура воды на входе достигнет заданного значения, устройство отключится. Оно снова самостоятельно включится (при условии, что будет включен насос плавательного бассейна), если температура в плавательном бассейне понизится хотя бы на 0.5°C от заданной.

Контроллер пропускной способности - Устройство снабжено контроллером пропускной способности, который включает тепловой насос при включенном фильтрационном насосе плавательного бассейна, и отключает тепловой насос при неработающем фильтрационном насосе. При отсутствии поступления воды на экране регулятора загорится код ошибки E03 (См. § 6.4).

Задержка - устройство работает с задержкой в 3 минуты с целью защиты компонентов управляющей цепи, устранения любой нестабильности при повторном запуске и всех помех в цепи контактора. Благодаря данной задержке устройство автоматически включается примерно через 3 минуты после полного отключения управляющей цепи. Таким же образом кратковременное отключение тока активизирует цепь задержки включения.

4. ИНТЕРФЕЙС ПОЛЬЗОВАТЕЛЯ

4.1 Общие сведения

Тепловой насос оборудован панелью цифрового управления с сенсорным экраном, соединенной электрически с устройством и настроенным на заводе на режим подогрева.

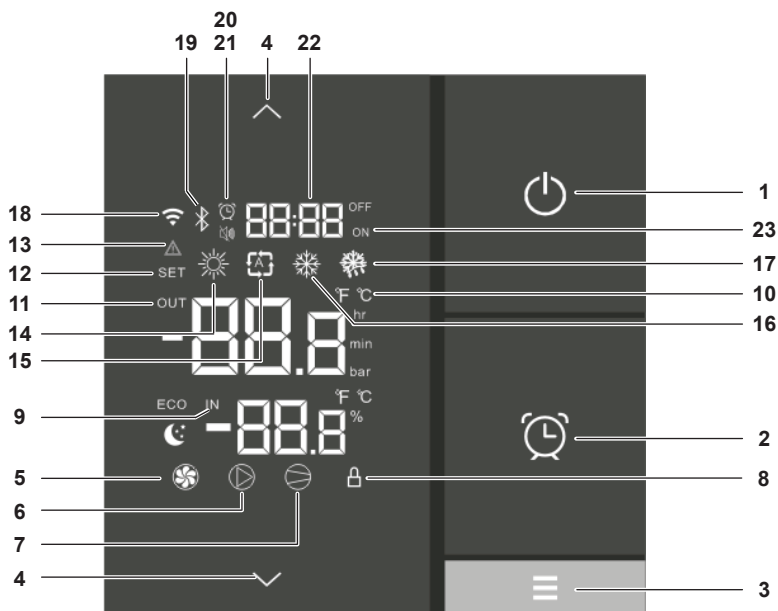

Условные обозначения

1		Включение / Выключение / Отмена
2		Установка времени и таймеров
3		Выбор режима работы
4		Прокрутка вверх / вниз, +°C / -°C
5		Включение вентилятора
6		Включение сухого контакта OUT2
7		Включение компрессора
8		Экран заблокирован
9		Вход воды
10		Градусы Цельсия / градусы Фаренгейта
11		Выход воды
12		Задание дополнительных параметров

13		Отказ системы
14		Режим подогрева
15		Автоматический режим
16		Режим охлаждения
17		Режим оттаивания
18		Неприменимо
19		Соединение Bluetooth
20		Запрограммирован таймер
21		Индикатор режима тишины / таймер
22		Время / время таймеров
23		Запрограммированы таймеры включения и выключения

4. ИНТЕРФЕЙС ПОЛЬЗОВАТЕЛЯ (продолжение)

Режим OFF/ВЫКЛ

Когда тепловой насос находится в спящем режиме (режим OFF), на экран регулятора выводится надпись OFF, и через одну минуту экран переходит в режим экономии энергии.

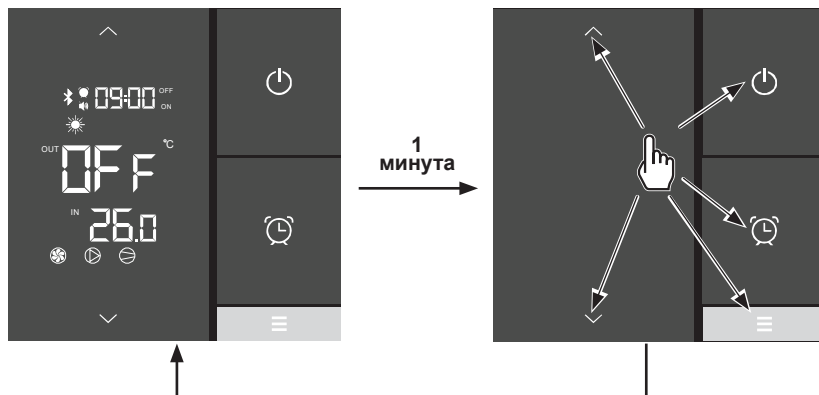

Для возврата к полной индикации нажмите на любую кнопку.

Режим ON/ВКЛ

Когда тепловой насос работает или находится в режиме регулировки (режим ON), на экран регулятора выводится температура воды на входе и выходе, и через одну минуту экран переходит в режим экономии энергии.

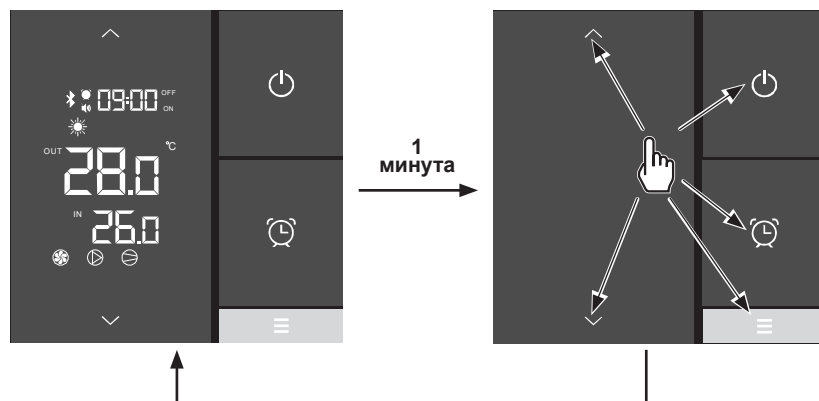

Для возврата к полной индикации нажмите на любую кнопку.

4. ИНТЕРФЕЙС ПОЛЬЗОВАТЕЛЯ (продолжение)

4.2 Регулировка расхода воды

Открыв вентили входа и выхода воды, отрегулируйте так называемый "перепускной" вентиль так, чтобы разница между температурами воды на входе и выходе составляла 2°C (см. § 3.1 принципиальной схемы).

Вы можете проверить регулировку, выведя температуру на входе и выходе непосредственно на панель управления и выполнив процедуру ниже.



Затем отрегулируйте перепускной вентиль так, чтобы разность температур на входе и выходе составляла 2°C.

Нажмите на , чтобы вывести меню.

- При открывании перепускного вентиля поток через теплообменник теплового насоса уменьшается, поэтому разность температур на входе и выходе увеличивается.
- При закрывании перепускного вентиля поток через теплообменник теплового насоса увеличивается, поэтому разность температур на входе и выходе уменьшается.

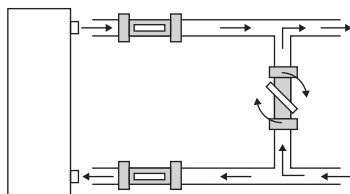









Регулировку можно проверить, посмотрев температуру на входе и выходе (1-2) непосредственно через приложение «EyesPool Inverter Connect» (см. § 4.6).



4. ИНТЕРФЕЙС ПОЛЬЗОВАТЕЛЯ (продолжение)

4.3 Установка времени

После выполнения регулировок нажмите на  для подтверждения. Сохранение настроек происходит автоматически, если в течение 5 секунд не производится никаких действий.













- Нажмите на , и выводимое время начнет мигать.
- Нажмите на , и выводимые часы начнут мигать. Установите часы с помощью кнопок  и .
- Нажмите на , затем установите минуты с помощью кнопок  и .
- Подтвердите нажатием на .

4.4 Установка таймеров включения и выключения

Установка этой функции нужна в том случае, если Вы хотите, чтобы тепловой насос работал в течение более короткого периода времени по сравнению с установленным временем фильтрации. Вы также можете запрограммировать произвольное время включения и выключения или просто отключить временной рабочий диапазон (например, ночью).

Вы можете запрограммировать таймер включения (ON) и таймер выключения (OFF).

Программирование таймера включения (ON)

- Нажмите на , на 2 секунды, чтобы пиктограмма  начала мигать.
- Нажмите на , и индикация  начнет мигать ().
- Нажмите на , чтобы установить часы с помощью кнопок  и .
- Нажмите на , чтобы установить минуты с помощью кнопок  и .
- Подтвердите, нажав на , затем нажмите на , чтобы вернуться к главному экрану.

















Сохранение настроек происходит автоматически, если в течение 20 секунд не производится никаких действий.

Минуты задаются интервалами по 10 минут.

Если под временем на главном экране выводится ON, значит таймер включения (ON) запрограммирован.

4. ИНТЕРФЕЙС ПОЛЬЗОВАТЕЛЯ (продолжение)

Программирование таймера выключения (OFF)







- Нажмите на  на 2 секунды, чтобы пиктограмма  начала мигать.
- Нажмите на , и индикация  начнет мигать ().
- Нажмите на  и выводимая индикация  начнет мигать ().
- Нажмите на , чтобы установить часы с помощью кнопок  и .
- Нажмите на , чтобы установить минуты с помощью кнопок  и .
- Подтвердите, нажав на , затем нажмите на , чтобы вернуться к главному экрану.

Сохранение настроек происходит автоматически, если в течение 20 секунд не производится никаких действий.

Минуты задаются интервалами по 10 минут.







Если над временем на главном экране выводится OFF, значит таймер выключения (OFF) запрограммирован.

Проверка таймеров







- Нажмите на  на 2 секунды, чтобы пиктограмма  начала мигать.
- Нажмите на , и время включения  начнет мигать.
- Нажмите на , и время выключения  начнет мигать.
- Нажмите на , чтобы вернуться к главному экрану.

Если запрограммирован таймер включения или таймер выключения, на главный экран выводится пиктограмма .

Отключение таймеров включения (ON) и выключение (OFF)











- Нажмите на  на 2 секунды, чтобы пиктограмма  начала мигать.
- Нажмите 2 раза на , и часы включения начнут мигать .
- Нажмите на , чтобы отключить таймер включения .

По завершении этапа 3 нажмите на , чтобы вернуться к главному экрану или перейти к этапу 4 для продолжения.

- Нажмите на , чтобы перейти ко времени выключения .
- Нажмите на , и часы выключения начнут мигать .
- Нажмите на , чтобы отключить таймер выключения .
- Нажмите на , чтобы вернуться к главному экрану.

4. ИНТЕРФЕЙС ПОЛЬЗОВАТЕЛЯ (продолжение)

















Отключение таймера выключения (OFF)

- Нажмите на  на 2 секунды, чтобы пиктограмма  начала мигать.
- Нажмите 2 раза на , и часы включения начнут мигать .
- Нажмите на , чтобы перейти ко времени выключения .
- Нажмите на , и часы выключения начнут мигать .
- Нажмите на , чтобы отключить таймер выключения .
- Нажмите на , чтобы вернуться к главному экрану.











4.5 Настройка функции «Таймер режима ТИШИНЫ»

Режим ТИШИНЫ позволяет использовать тепловой насос в экономичном и очень тихом режиме, если достаточно небольшого нагрева (поддержание температуры в бассейне или необходимость в очень тихом режиме).

Программирование таймера режима ТИШИНЫ

- Нажмите на  на 2 секунды, чтобы пиктограмма  начала мигать.
- Нажмите на , и пиктограмма  начнет мигать.
- Нажмите на , и индикация  начнет мигать.
- Нажмите на , чтобы установить время включения с помощью кнопок  и .
- Нажмите на , затем на , и индикация  начнет мигать.
- Нажмите на , чтобы установить время с помощью кнопок  и .
- Нажмите на  для подтверждения, затем на , чтобы вернуться к главному экрану.

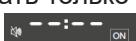
Отключение таймера режима ТИШИНЫ







- Нажмите на  на 2 секунды, чтобы пиктограмма  начала мигать.
- Нажмите на , и пиктограмма  начнет мигать.
- Нажмите на , и время включения  начнет мигать.
- Нажмите на , и начнут мигать только часы.
- Нажмите на , и индикация  начнет мигать.
- Нажмите на , чтобы вернуться к главному экрану.

При отключении таймера включения всегда отключается и таймер выключения.

Шаг настройки — «почасовой».

4. ИНТЕРФЕЙС ПОЛЬЗОВАТЕЛЯ (продолжение)

Проверка таймера режима ТИШИНЫ

- Нажмите на  на 2 секунды, чтобы пиктограмма  начала мигать.
- Нажмите на , и пиктограмма  начнет мигать .
- Нажмите на , чтобы вывести таймер включения .
- Нажмите на , чтобы вывести таймер выключения .
- Нажмите на , чтобы вернуться к главному экрану.

Если на главный экран выводится пиктограмма , значит для режима ТИШИНЫ запрограммирован таймер включения или таймер выключения.

4.6 Подключение Bluetooth — дистанционное управление

Тепловой насос имеет функцию Bluetooth.

С помощью приложения «*EyesPool Inverter Connect*» вы можете использовать свой смартфон как пульт дистанционного управления, чтобы управлять тепловым насосом на расстоянии до 10 м на открытом пространстве.

Для включения функции  **Bluetooth**:

- ▶ Скачайте бесплатно приложение «*EyesPool Inverter Connect*» с



- ▶ Создайте аккаунт в приложении.
- ▶ Следуйте указаниям видео (ссылки ниже), чтобы подключить свой смартфон к тепловому насосу:
<https://www.hayward.fr/article/tutoriels-hayward/s-line-pro-bluetooth-appairage>



4. ИНТЕРФЕЙС ПОЛЬЗОВАТЕЛЯ (продолжение)

4.7 Выбор режима работы

Нагрев — автоматический режим — охлаждение



Если тепловой насос установлен на заводе на режим «Только тепло» или «Только холод», переключение режимов недоступно.

Нажмите на кнопку  для изменения режима: нагрев — автоматический режим — охлаждение.

Нагрев

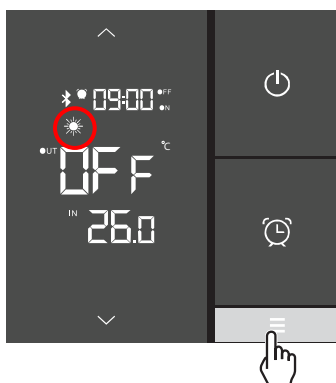

Автоматический режим



Охлаждение







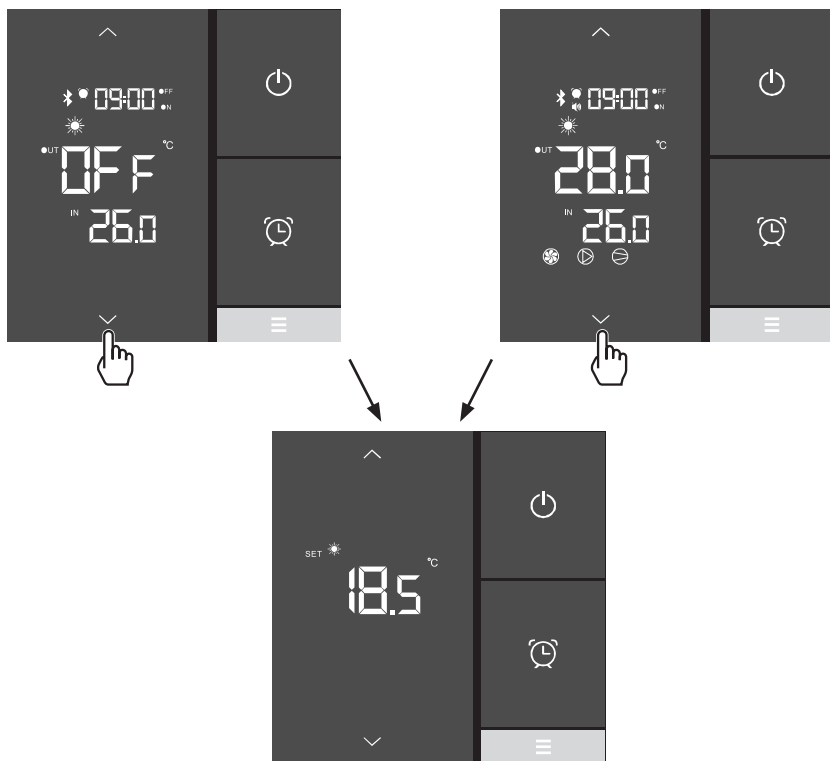

4. ИНТЕРФЕЙС ПОЛЬЗОВАТЕЛЯ (продолжение)

4.8 Установка и визуализация заданного значения

Температура воды

Установка заданного значения производится с точностью 0,5°C — как в режиме OFF, так и в режиме ON.



- Нажимайте на  или , чтобы заданное значение начало мигать.
- Нажимайте на  или , чтобы установить нужное заданное значение.
- Нажмите на , чтобы подтвердить, или на , чтобы отменить.

Сохранение настройки происходит автоматически, если в течение 5 секунд не производится никаких действий.







Чтобы избежать деформации жаровых труб, рекомендуется никогда не превышать температуру 30°C.

4. ИНТЕРФЕЙС ПОЛЬЗОВАТЕЛЯ (продолжение)

4.9 Блокировка и разблокировка сенсорного экрана

Блокировка и разблокировка экрана может производиться как в режиме ON, так в режиме OFF.

- Нажмите на  на 5 секунд, чтобы появилась пиктограмма .
- Для разблокировки нажмите на , чтобы пиктограмма  исчезла.

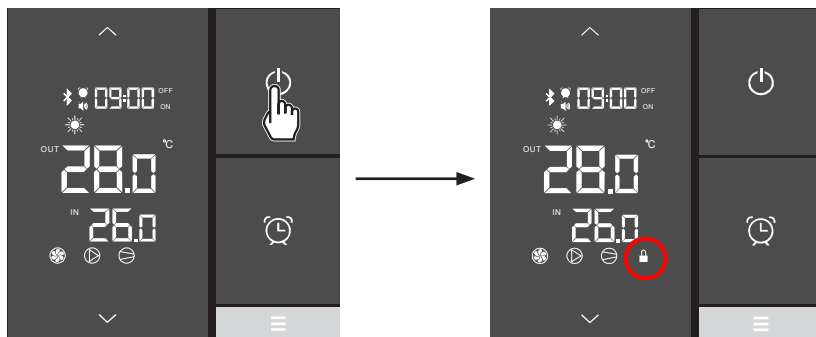

5. ТЕХНИЧЕСКОЕ ОБСЛУЖИВАНИЕ И КОНСЕРВАЦИЯ НА ЗИМУ

5.1 Техническое обслуживание

Для гарантирования продолжительной и надежной работы теплового насоса рекомендуется раз в год проводить следующие операции по обслуживанию устройства.

- Очистите испаритель с помощью мягкой зубной щетки или воздушной/водяной струи (**Внимание: никогда не используйте для очистки высокое давление**).
- Проверьте, что конденсат хорошо стекает.
- Проверьте надежность гидротехнических и электрических соединений.
- Проверьте гидравлическую герметичность конденсатора.
- Проверку изоляции холодильной системы выполняет уполномоченный специалист с помощью детектора течи.



Перед производством любых работ по техническому обслуживанию теплового насоса необходимо отсоединить его от источника питания. Все операции по техническому обслуживанию должны производиться только специально подготовленным персоналом, имеющим опыт работы с жидкими хладагентами.

5.2 Консервация на зиму

- Переведите тепловой насос в режим "ВЫКЛ."
- Отключите тепловой насос от источника питания.
- Слейте содержимое конденсатора для предотвращения риска повреждения (риск возможного замерзания).
- Закройте "перепускной" вентиль и отсоедините штуцерные соединения входа/выхода.
- С помощью пистолета высокого давления максимально выдуйте остатки воды из конденсатора.
- Перекройте вход и выход для воды теплового насоса для предотвращения попадания туда инородных тел.
- Укройте тепловой насос предназначенным для этих целей зимним чехлом.



Любые неполадки, вызванные неправильной консервацией на зимний период, аннулируют гарантию.

6. ПРИЛОЖЕНИЯ

6.1 Электрические схемы

HP5081DT3LVM / HP5111DT3LV

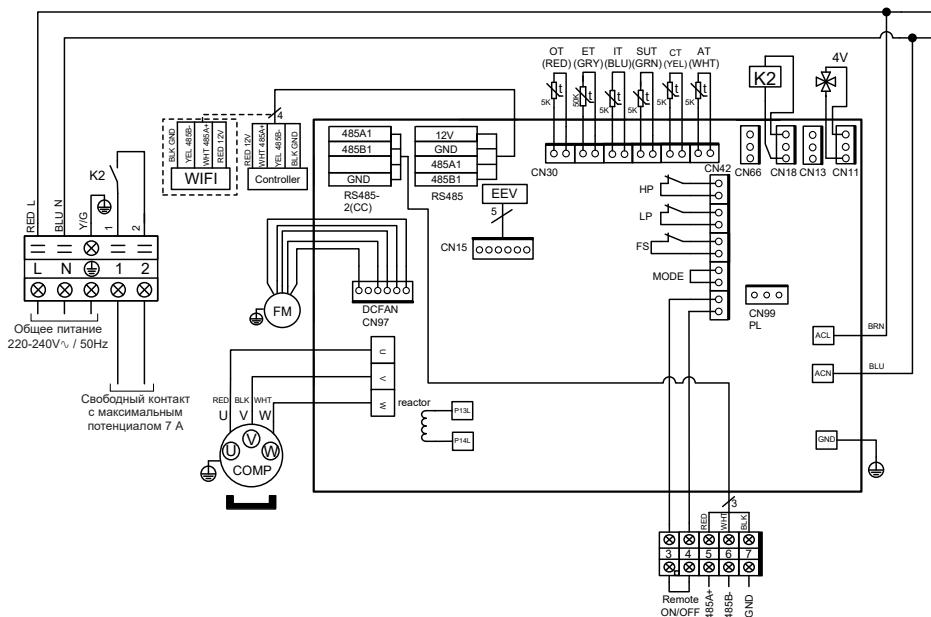

ПРИМЕЧАНИЯ

- | | |
|--|---|
| AT : ДАТЧИК ТЕМПЕРАТУРЫ ВОЗДУХА | LP : ПРЕССОСТАТ НИЗКОГО ДАВЛЕНИЯ |
| COMP : КОМПРЕССОР | OT : ДАТЧИК ТЕМПЕРАТУРЫ ВОДЫ НА ВЫХОДЕ |
| CT : ДАТЧИК ТЕМПЕРАТУРЫ ИСПАРИТЕЛЯ | SUT : ДАТЧИК ТЕМПЕРАТУРЫ ВСАСЫВАНИЯ |
| EEV : ЭЛЕКТРОННЫЙ РЕДУКТОР | 4V : 4-Х КАНАЛЬНЫЙ ВЕНТИЛЬ |
| FM : МОТОР ВЕНТИЛЯТОРА | K2 : СВОБОДНЫЙ КОНТАКТ С |
| FS : ДЕТЕКТОР НАЛИЧИЯ ВОДЫ | ET : ДАТЧИК ТЕМПЕРАТУРЫ НАГНЕТАНИЯ |
| NP : ПРЕССОСТАТ ВЫСОКОГО ДАВЛЕНИЯ | --- : ДОПОЛНИТЕЛЬНО |
| IT : ДАТЧИК ТЕМПЕРАТУРЫ ВОДЫ НА ВХОДЕ | |

6. ПРИЛОЖЕНИЯ (продолжение)

HP5151DT3LV

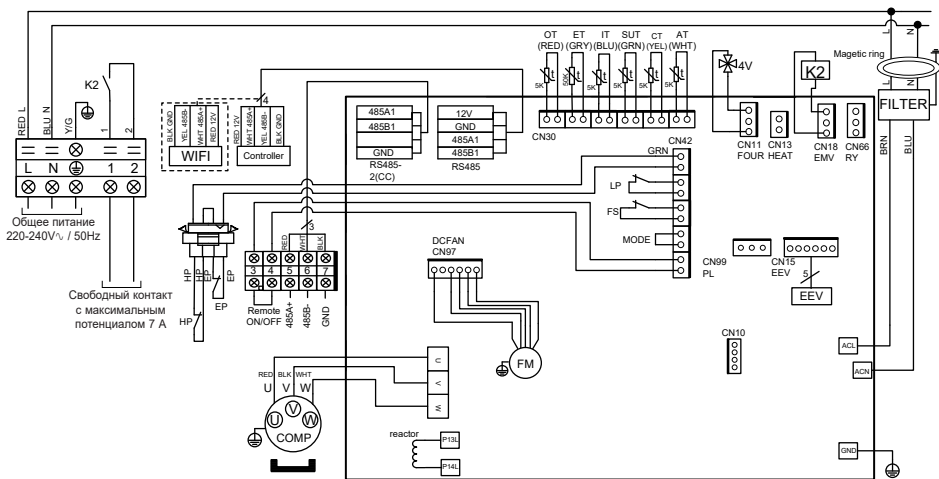

ПРИМЕЧАНИЯ

- | | |
|--|---|
| AT : ДАТЧИК ТЕМПЕРАТУРЫ ВОЗДУХА | LP : ПРЕССОСТАТ НИЗКОГО ДАВЛЕНИЯ |
| COMP : КОМПРЕССОР | OT : ДАТЧИК ТЕМПЕРАТУРЫ ВОДЫ НА ВЫХОДЕ |
| CT : ДАТЧИК ТЕМПЕРАТУРЫ ИСПАРИТЕЛЯ | SUT : ДАТЧИК ТЕМПЕРАТУРЫ ВСАСЫВАНИЯ |
| EEV : ЭЛЕКТРОННЫЙ РЕДУКТОР | 4V : 4-Х КАНАЛЬНЫЙ ВЕНТИЛЬ |
| FM : МОТОР ВЕНТИЛЯТОРА | K2 : СВОБОДНЫЙ КОНТАКТ С |
| FS : ДЕТЕКТОР НАЛИЧИЯ ВОДЫ | ET : ДАТЧИК ТЕМПЕРАТУРЫ НАГРЕТАНИЯ |
| HP : ПРЕССОСТАТ ВЫСОКОГО ДАВЛЕНИЯ | ----- : ДОПОЛНИТЕЛЬНО |
| IT : ДАТЧИК ТЕМПЕРАТУРЫ ВОДЫ НА ВХОДЕ | |

6. ПРИЛОЖЕНИЯ (продолжение)

6.2 Включение подогрева в качестве приоритета

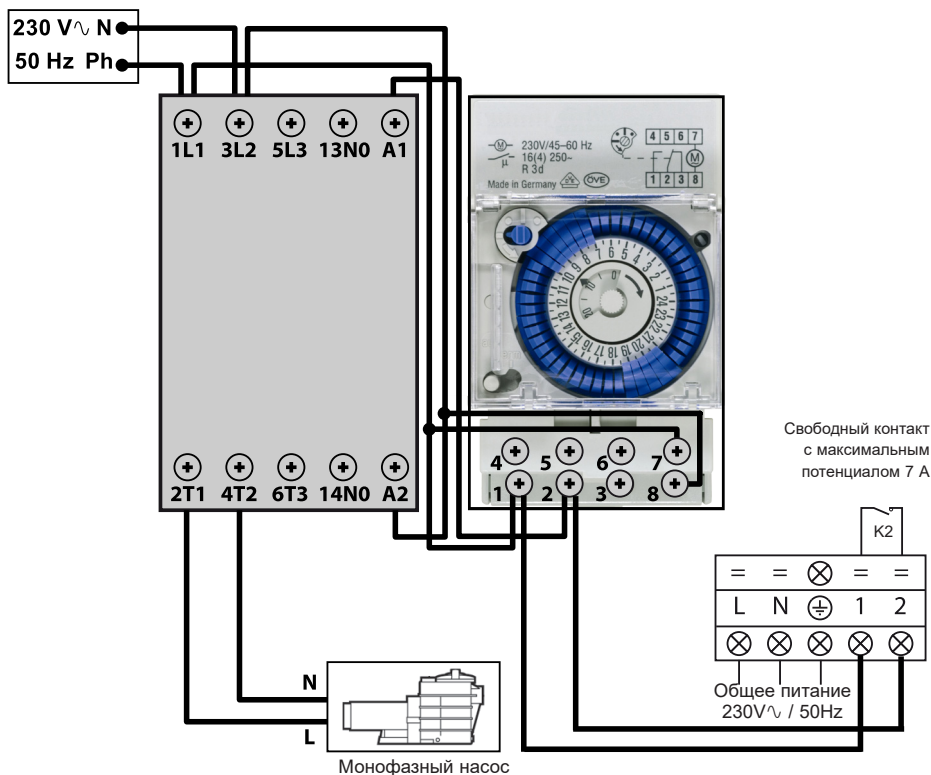

Разъемы 1 и 2 обеспечивают подачу питания на бесполярный контакт при напряжении 230V~ / 50Hz.

Подключите кабели к разъемам 1 и 2 в соответствии с указанной монтажной схемой для автоматической регулировки насоса фильтрации по циклам в 2 минуты каждый час, когда температура резервуара снижается ниже установленного значения.



Никогда не подключать питание фильтрационного насоса прямо к клеммам 1 и 2.

6. ПРИЛОЖЕНИЯ (продолжение)

6.3 Вид в разборе и съемные элементы

HP5081DT3LV / HP5111DT3LV / HP5151DT3LV

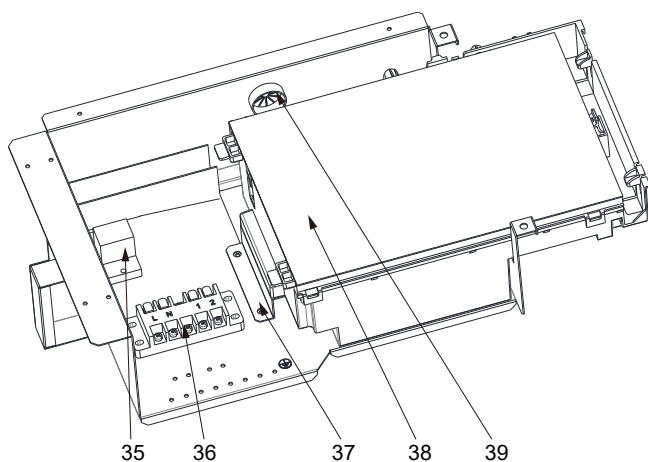
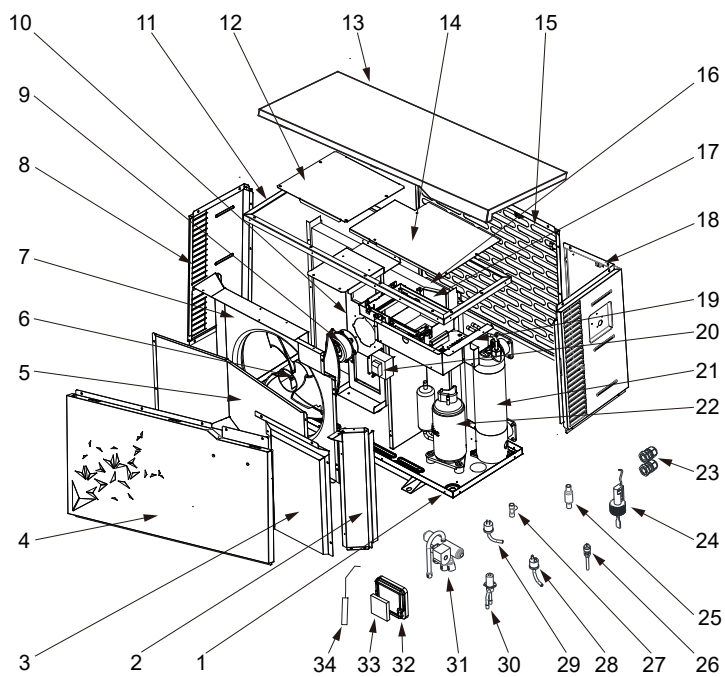

6. ПРИЛОЖЕНИЯ (продолжение)

Индикция	Название	Справочный номер	HP5081DT3LV	HP5111DT3LV	HP5151DT3LV
1	/	/	/	/	/
2	/	/	/	/	/
3	/	/	/	/	/
4	Панель передняя	HWX80715842	✓	✓	нет данных
		HWX80715857	нет данных	нет данных	✓
5	/	/	/	/	/
6	Винт вентилятора	HWX301030000006	✓	✓	нет данных
		HWX20000270004	нет данных	нет данных	✓
7	/	/	/	/	/
8	Левая панель	HWX80713420	✓	✓	нет данных
		HWX80713423	нет данных	нет данных	✓
9	Мотор вентилятора DC	HWX80200018	✓	✓	нет данных
		HWX20000330132	нет данных	нет данных	✓
10	Опора двигателя	HWX80708597	✓	✓	нет данных
		HWX80709977	нет данных	нет данных	✓
11	/	/	/	/	/
12	/	/	/	/	/
13	Верхняя панель	HWX80708601	✓	✓	нет данных
		HWX80709984	нет данных	нет данных	✓
14	/	/	/	/	/
15	Задняя панель	HWX80710829	✓	✓	нет данных
		HWX80710966	нет данных	нет данных	✓
16	Пластинчатый испаритель	HWX80600849	✓	нет данных	нет данных
		HWX80600781	нет данных	✓	нет данных
		HWX80600835	нет данных	нет данных	✓
17	/	/	/	/	/
18	Правая панель	HWX80713421	✓	✓	нет данных
		HWX80713424	нет данных	нет данных	✓
19	/	/	/	/	/
20	Реактивность	HWX82500020	✓	✓	нет данных
		HWX82500021	нет данных	нет данных	✓
21	Конденсатор Titane/ПВХ	HWX80600939	✓	нет данных	нет данных
		HWX80600940	нет данных	✓	нет данных
		HWX80600096	нет данных	нет данных	✓
22	Компрессор	HWX20000110448	✓	✓	нет данных
		HWX80100046	нет данных	нет данных	✓
23	Сальник	HWX20012249	✓	✓	нет данных
		HWX20012238	нет данных	нет данных	✓
24	Датчик расхода	HWX83000068	✓	✓	✓
25	Фильтр Ø9.7-Ø9.7 (Ø19)	HWX20000140178	✓	✓	нет данных
	Фильтр Ø9.7-Ø9.7 (Ø28)	HWX20041444	нет данных	нет данных	✓
26	Замер давления 40mm-1/2"	HWX20000140150	✓	✓	✓
27	T-образный коннектор Ø9.52-2 x Ø6.35(T) x 1.0	HWX30403000002	✓	✓	нет данных
	T-образный коннектор Ø6.5-2 x Ø6.5(T) x 0.75	HWX20001460	нет данных	нет данных	✓
28	Реле низкого давления NO 0.30MPa/0.15MPa	HWX20000360157	✓	✓	✓
29	Реле высокого давления NC 3.2MPa/4.4MPa	HWX20013605	✓	✓	✓
30	Электронный редуктор	HWX81000011	✓	✓	нет данных
		HWX81000017	нет данных	нет данных	✓
31	4-ходовой клапан	HWX20041437	✓	✓	нет данных
		HWX20000140485	нет данных	нет данных	✓
32	Кронштейн контроллера	HWX80901004	✓	✓	✓
33	Контроллер, 7 сегментов	HWX72200312	✓	✓	✓

6. ПРИЛОЖЕНИЯ (продолжение)

HP5081DT3LV / HP5111DT3LV / HP5151DT3LV

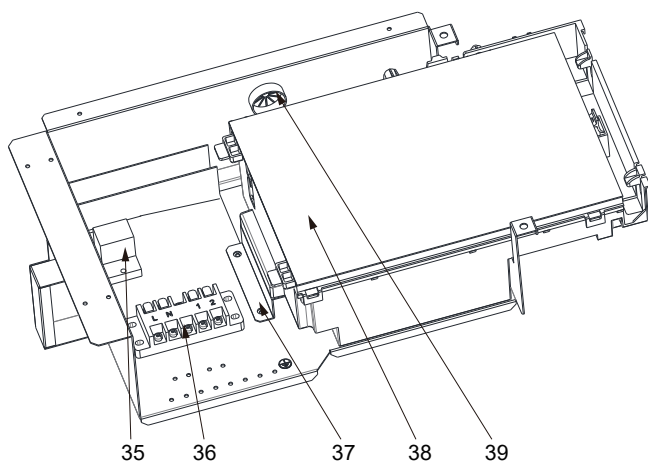
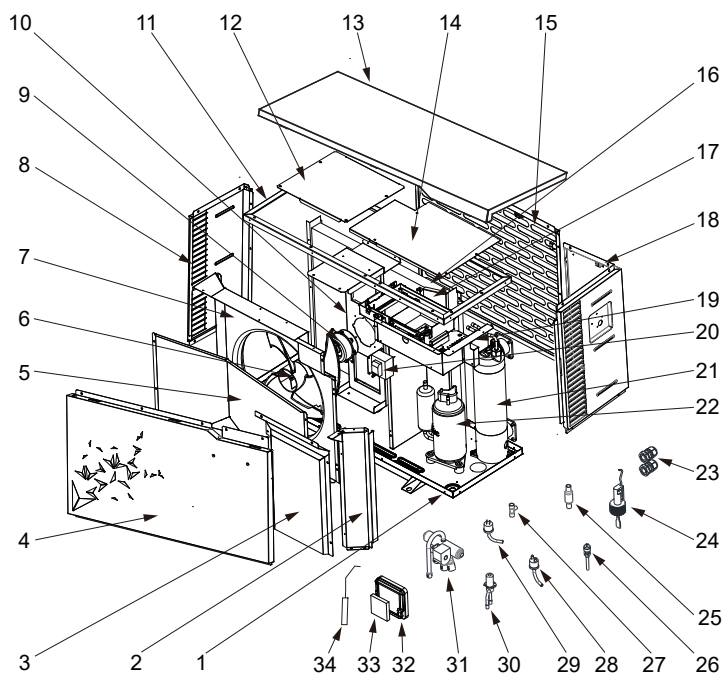

6. ПРИЛОЖЕНИЯ (продолжение)

Индикция	Название	Справочный номер	HP5081DT3LV	HP5111DT3LV	HP5151DT3LV
34	Воды на выходе зонда 5к-410мм	HWX83000050	✓	✓	✓
	Воды на входе зонда 5к-850мм	HWX83000052	✓	✓	✓
	датчик нагнетания компрессора 50к-660мм	HWX83000026	✓	✓	✓
	Датчик всасывания компрессора 5к-560мм	HWX83000044	✓	✓	нет данных
	Датчик всасывания компрессора 5к-760мм	HWX83000053	нет данных	нет данных	✓
	Датчик размораживания 5к-680мм	HWX83000051	✓	✓	нет данных
	Датчик размораживания 5к-1040мм	HWX83000045	нет данных	нет данных	✓
	Датчик температуры воздуха 5к-350мм	HWX83000049	✓	✓	✓
35	Реле К2	HWX20000360297	✓	✓	✓
36	Переходник, L-N-GND -5-х контактный 4мм ²	HWX40003901	✓	✓	✓
37	/	/	/	/	/
38	Управляющая электронная плата	HWX72200168SL08	✓	нет данных	нет данных
		HWX72200168SL11	нет данных	✓	нет данных
		HWX72200168SL15	нет данных	нет данных	✓
39	/	/	/	/	/

6. ПРИЛОЖЕНИЯ (продолжение)

6.4 Гид по устранению неисправностей



Некоторые операции должны выполняться квалифицированными специалистами.

В случае неисправности на экран выводится следующая индикация:

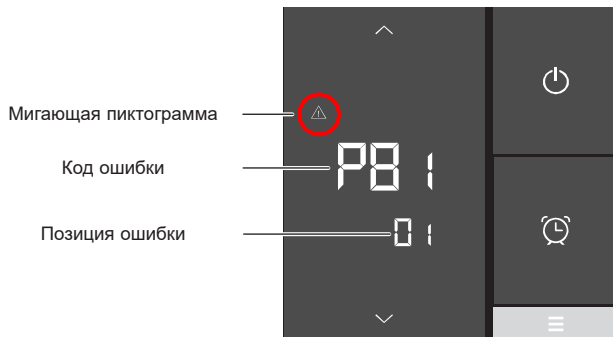

В случае ошибки нажимайте на  или  для прокрутки кодов ошибок. См. таблицу ниже.



После решения проблемы ошибка будет сброшена автоматически, треугольник исчезнет.

6. ПРИЛОЖЕНИЯ (продолжение)

Неисправности	Коды ошибок	Описание	Устранение
Отказ датчика на входе воды (IT)	P01	Датчик разомкнут или произошло короткое замыкание	Проверьте соединение на разъеме удлинителя или замените датчик
Отказ датчика на выходе воды (OT)	P02		
Отказ датчика температуры окружающей среды (AT)	P04		
Отказ датчика оттаивания (CT)	P05		
Отказ датчика всасывания компрессора (SUT)	P07		
Отказ датчика нагнетания компрессора (ET)	P08 1		
Отказ высокого давления	E01	Датчик разомкнут или произошло короткое замыкание	Проверьте соединение на разъеме удлинителя или замените датчик
			Проверьте расход воды
			Проверьте датчик расхода воды
			Проверьте открытие вентиляей
			Проверьте перепускной клапан
			Проверьте засорение испарителя
			Температура воды слишком высокая
Отказ низкого давления	E02	Датчик разомкнут или произошло короткое замыкание	Проверьте соединение на разъеме удлинителя или замените датчик
			Значительная утечка охлаждающей жидкости, найдите течь с помощью детектора
			Низкое количество поступающего воздуха, проверьте скорость вращения вентилятора
			Проверьте засорение испарителя, очистите его поверхность
			Проблема с конденсатом после обслуживания, опорожните и проведите вакуумирование холодильной системы. Слишком большая нагрузка жидкости, удалите жидкость в емкости с жидкостью

6. ПРИЛОЖЕНИЯ (продолжение)

Неисправности	Коды ошибок	Описание	Устранение
Неисправность детектора пропускной способности	E03	Датчик открыт или произошло короткое замыкание	Проверьте соединение CN29/OVT на карте или замените датчик
			Нехватка воды, проверьте работу фильтрационной помпы
			Проверьте, открыты ли стопорные вентили
			Проверить регулировку перепускной системы
Разница температуры на входе/ выходе > 13°C	E06	Применимо только в режиме охлаждения	Нехватка воды, проверьте работу фильтрационной помпы
			Проверить регулировку перепускной системы
Защита от замерзания	E07	Температура воды на выходе < 4°C	Выключите тепловой насос, слейте воду из конденсатора: риск замерзания
Сбои в передаче информации	E08	Нет связи между электронной картой и интерфейсом пользователя	Проверьте соединения по электрической схеме
Защита от замерзания — уровень 1	E19	2°C < температура воды < 4°C и температура воздуха < 0°C	Остановите работу теплового насоса, слейте конденсатор, чтобы избежать замерзания; по умолчанию тепловой насос запускает фильтрационный насос для предотвращения замерзания
Защита от замерзания — уровень 2	E29	Температура воды < 2°C и температура воздуха < 0°C	Остановите работу теплового насоса, слейте конденсатор, чтобы избежать замерзания; по умолчанию тепловой насос запускает фильтрационный насос и тепловой насос для предотвращения замерзания.
Отказ двигателя вентилятора	F03 I	Двигатель заблокирован или отсутствует соединение	Проверьте, чтобы двигатель вращался свободно; проверьте соединение CN97/DCFan; замените двигатель
Отказ двигателя вентилятора	F05 I	Отсутствует соединение	Проверьте соединение DCFAN/CN97; замените двигатель
Температура окружающей среды слишком низкая	EP	Достигнут предел работы	Выключите тепловой насос
Тепловой насос не запускается	- - - OFF	Разомкнут контакт (5-6) Remote On/Off	Замкните контакт (5-6) Remote On/Off (см. электрическую схему)

6. ПРИЛОЖЕНИЯ (продолжение)

6.5 Гарантия

ГАРАНТИЙНЫЕ ОБЯЗАТЕЛЬСТВА

На всю продукцию компании HAYWARD в течение двух лет с момента приобретения распространяется гарантия отсутствия дефектов, связанных с работой или материалами. Настоящая гарантия действительна лишь при предъявлении документа, подтверждающего факт и дату покупки. В связи с этим мы рекомендуем сохранять товарный чек. Гарантия компании HAYWARD сводится лишь к ремонту или замене, по выбору компании HAYWARD, дефектного изделия при условии его нормальной эксплуатации в соответствии с требованиями инструкции по эксплуатации, отсутствия каких-либо модификаций изделия и использования компонентов и запасных частей исключительно компании HAYWARD. Действие гарантии не распространяется на последствия воздействия мороза и химических веществ. Все прочие расходы (доставка, производство работ, ...) не включены в гарантию. Компания HAYWARD не несет ответственности за любой ущерб, прямой или косвенный, являющийся следствием неправильной установки, подключения или работы изделия. Для того чтобы воспользоваться гарантией и потребовать возмещения стоимости или замены изделия, обратитесь к Вашему продавцу. Возврат изделия на завод-изготовитель невозможен без нашего предварительного письменного согласия. Гарантия не распространяется на быстроизнашивающиеся детали.

Намеренно оставлено пустым

Намеренно оставлено пустым



HAYWARD POOL EUROPE

Parc Industriel de la Plaine de l'Ain
Allée des Chênes
01150 Saint-Vulbas
France
<http://www.hayward.fr>

